

CNC Werkzeughalter  
CNC Tool Holders





Liebe Leserin, lieber Leser,

an der „Schneide“ wird bekanntlich das Geld verdient. Dabei beeinflusst die Produktivität dieser Schneide die Gesamtkosten von Zerspanungsprozessen, zu denen sie selbst nur zwischen 4 – 6 % beiträgt. Diesen Aussagen werden wohl die Mehrzahl aller Produktions und Zerspanungsfachleute zustimmen.

Doch was unternehmen Sie, um die Leistungsfähigkeit der Schneide voll auszunutzen und deren Standwege zu erhöhen?

Das vorliegende Handbuch soll Sie bei der Auswahl von optimalen Spannmitteln für Ihre „Schneiden“ unterstützen.

Unsere lange Erfahrung als traditionsreiches Familienunternehmen hilft uns dabei, Produkte zu entwickeln, denen Sie vertrauen können, und in diesem Handbuch ein umfassendes Produktspektrum für Sie zusammenzustellen.

Dabei sind zahlreiche Verbesserungen eingeflossen. „Immer besser“ ist für uns kein Schlagwort. Es ist ein Qualitätsversprechen.

Und unsere Produkte und wir selbst halten, was wir versprechen.

Über das dargestellte Programm hinaus können wir Ihnen unterschiedlichste anwendungs-spezifische Lösungen anbieten.

Sprechen Sie uns auch für neue Lösungen gerne an.

Viele denken nach, wir denken gerne vor.

Im Namen des ganzen Bilz Teams

Dear Reader,

As everyone knows, money is made at the “cutting edge”. The productivity of this cutting edge influences the total costs of cutting processes, whereas its share amounts to 4 – 6 % only.

Most production and cutting experts will agree with these statements.

What do you undertake to fully profit from the performance of the cutting edge and to increase its tool life?

This manual will support you in selecting the optimal clamping tools for your “cutting edges”.

Our long experience as a traditional family-run company helps us to develop products you can rely on and to compile a comprehensive product range in this manual. Many improvements have been included.

“Always better” is not just a slogan for us. It is a promise for quality. And we and our products keep our promises.

Beyond this product range we can offer you various custom-designed solutions.

Please talk to us about new solutions for your applications.

Many people react, we act.

On behalf of the whole Bilz Team

- A JIS B 6339 / MAS 403 BT / ISO7388-2 (BT)  
Werkzeugaufnahmen  
JIS B 6339 / MAS 403 BT / ISO7388-2 (BT) Tool holders
- 
- FBT - Steilkegel mit Plananlage  
FBT - Face contact holders
- 
- B DIN 69871 / ISO7388-1 (SK) Werkzeugaufnahmen  
DIN 69871 / ISO7388-1 (SK) Tool holders
- 
- C DIN 69893(HSK-A) Werkzeugaufnahmen  
DIN 69893 (HSK-A) Tool holders
- 
- DIN 69893(HSK-E) Werkzeugaufnahmen  
DIN 69893 (HSK-E) Tool holders
- 
- DIN 69893(HSK-F) Werkzeugaufnahmen  
DIN 69893 (HSK-F) Tool holders
- 
- D Zubehör  
Accessories
- 
- E Ersatzteile  
Spare parts
- 
- F Technische Spezifikationen  
Technical details

Erklärung der Piktogramme  
Illustration of the Pictograms



Rundlaufgenauigkeit CNC Halter  
Concentricity of the CNC holders

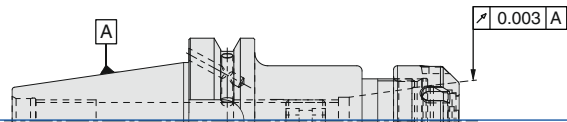

G2.5  
25000  
R.P.M.

Wuchtgute: Die Futter sind werkseitig feingewuchtet mit G2,5 bei 25.000 U/min, bei Futter mit Masse  $\geq 1$  kg bzw. bei Futter mit Masse  $< 1$  kg mit Restunwucht  $< 1$  g mm

Balancing: The chucks are factory-made finely balanced with G2,5 at 25.000 rpm, for chucks with the mass of  $\geq 1$  kg; or chucks with the mass of  $< 1$  kg with residual imbalance  $< 1$  g mm



Kühlmitteldurchführung  
Coolant feed



Mit Datenträgerbohrung  
With data carrier bore



Für tiefe Kavitäten geeignet – speziell für den Gesenk- und Formenbau  
Suitable for deep cavities – especially for the mold and die industry

Spannzangenfutter ER Collet chuck ER	A2 - A5
Super collet Spannzangenfutter Super collet chuck	A6 - A7
Fräseraufnahmen (Weldon / Whistle Notch) End mill holder (Weldon / Whistle Notch)	A8 - A11
Hochleistungsfräuserspannfutter Hi-power milling chuck	A12 - A13
Mini-Spannzangenhalter Mini collet holder	A14
Hydrodehnspannfutter Hydraulic expansion chuck	A15 - A16
Präzisions-Bohrfutter Precision drill chuck	A17
Aufnahmen für Morse-Kegel Morse taper holder	A17 - A18
Aufnahmen für Einschraubfräser Chuck for threaded milling heads	A19
Kombi-Aufsteckfräserdorn Combi shell mill holder	A20
Aufsteckfräserdorn Shell mill holder	A21 - A22
Reduzierhülsen Reduction Sleeves	A23
Bohrstangenrohlinge Boring bar blanks	A23
Kontrolldorn Test Arbor	A24

# Spannzangenfutter Typ ER für Spannzangen ISO 15488 (DIN 6499)

Collet chuck Type ER for collets to ISO 15488 (DIN 6499)

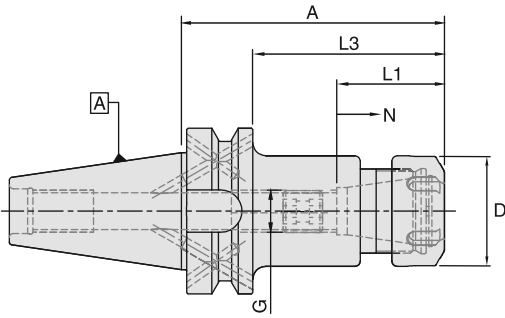

BT30											
Spannzange Collet Type	Bereich Range	D (mm)	A (mm)	L1 (mm)	L3 (mm)	G (mm)	N	Kühlmittelzufuhr Coolant supply	N/W (Kg)	Bezeichnung Designation	Ident No.
ER 11	1-7	19	70	23.5	48	M6	12	Form "AD"	0.5	WCCH/ER11-70/BT30	66658841M
ER 16	1-10	28	70	32.5	48	M10	12	Form "AD"	0.6	WCCH/ER16-70/BT30	4600581
ER 20	1-13	34	70	38.0	48	M12	12	Form "AD"	0.7	WCCH/ER20-70/BT30	5065866
ER 25	2-16	42	70	41.0	48	M12	12	Form "AD"	0.7	WCCH/ER25-70/BT30	4600583
ER 32	2-20	50	70	47.0	48	M12	12	Form "AD"	0.8	WCCH/ER32-70/BT30	5044372
ER 40	3-26	63	70	58.5	40	M12	12	Form "AD"	0.8	WCCH/ER40-70/BT30	66658843M
ER 11	1-7	19	100	23.5	78	M6	12	Form "AD"	0.5	WCCH/ER11-100/BT30	66658842M
ER 16	1-10	28	100	32.5	78	M10	12	Form "AD"	0.7	WCCH/ER16-100/BT30	6733380
ER 20	1-13	34	100	38.0	78	M12	12	Form "AD"	0.9	WCCH/ER20-100/BT30	6733382
ER 25	2-16	42	100	41.0	78	M12	12	Form "AD"	0.9	WCCH/ER25-100/BT30	6733384
ER 32	2-20	50	100	47.0	78	M12	12	Form "AD"	1.0	WCCH/ER32-100/BT30	6733386
ER 40	3-26	63	100	58.5	70	M22x1.5	12	Form "AD"	1.5	WCCH/ER40-100/BT30	66651396M

BT40											
Spannzange Collet Type	Bereich Range	D (mm)	A (mm)	L1 (mm)	L3 (mm)	G (mm)	N	Kühlmittelzufuhr Coolant supply	N/W (Kg)	Bezeichnung Designation	Ident No.
ER 11	1-7	19	70	23.5	43	M6	12	Form "AD/B"	1.0	WCCH/ER11-70/BT40	66658846M
ER 16	1-10	28	70	32.5	43	M10	12	Form "AD/B"	1.2	WCCH/ER16-70/BT40	6733387
ER 20	1-13	34	70	38.0	43	M12	12	Form "AD/B"	1.2	WCCH/ER20-70/BT40	6733390
ER 25	2-16	42	70	41.0	43	M16	12	Form "AD/B"	1.3	WCCH/ER25-70/BT40	6733393
ER 32	2-20	50	70	47.0	43	M22X1.5	12	Form "AD/B"	1.4	WCCH/ER32-70/BT40	6733396
ER 40	3-26	63	80	58.5	53	M22X1.5	12	Form "AD/B"	1.5	WCCH/ER40-80/BT40	6733399
ER 11	1-7	19	100	23.5	73	M6	12	Form "AD/B"	1.1	WCCH/ER11-100/BT40	66658847M
ER 16	1-10	28	100	32.5	73	M10	12	Form "AD/B"	1.3	WCCH/ER16-100/BT40	6733388
ER 20	1-13	34	100	38.0	73	M12	12	Form "AD/B"	1.4	WCCH/ER20-100/BT40	6733391
ER 25	2-16	42	100	41.0	73	M16	12	Form "AD/B"	1.4	WCCH/ER25-100/BT40	6733394
ER 32	2-20	50	100	47.0	73	M22X1.5	12	Form "AD/B"	1.7	WCCH/ER32-100/BT40	6733397
ER 40	3-26	63	100	58.5	73	M22X1.5	12	Form "AD/B"	1.9	WCCH/ER40-100/BT40	6733400
ER 11	1-7	19	160	23.5	133	M6	12	Form "AD/B"	1.2	WCCH/ER11-160/BT40	66658848M
ER 16	1-10	28	160	32.5	133	M10	12	Form "AD/B"	1.5	WCCH/ER16-160/BT40	5062757
ER 20	1-13	34	160	38.0	133	M12	12	Form "AD/B"	1.8	WCCH/ER20-160/BT40	5062758
ER 25	2-16	42	160	41.0	133	M16	12	Form "AD/B"	2.0	WCCH/ER25-160/BT40	5062759
ER 32	2-20	50	160	47.0	133	M22X1.5	12	Form "AD/B"	2.5	WCCH/ER32-160/BT40	5062760
ER 40	3-26	63	160	58.5	133	M22X1.5	12	Form "AD/B"	2.6	WCCH/ER40-160/BT40	5062761

Ersatzteile und Zubehör / Spare Parts & Accessories: Pg.D20 Pg.D2-D4 Pg.D5 Pg.D7

- Im Lieferumfang enthalten: mit Spannmutter (gewuchtet) und Verstelle schraube
- Höhere Wuchtgüte auf Anfrage
- siehe Seite D16-D17 für Drehmomentschlüssel Spezifikationen
- ❖ Für WCCH/ER16-160/BT40, D2=43.2mm & L4=55.5mm

- Delivery includes: Clamping nut (balanced) & adjusting screw
- Higher balancing grade on request
- Please refer page no.D16-D17 for torque wrench details
- ❖ Note: For WCCH/ER16-160/BT40, D2=43.2mm & L4=55.5mm

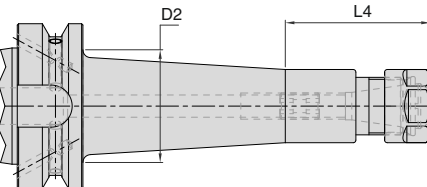

Spannzangenfutter Typ ER für Spannzangen ISO 15488 (DIN 6499)  
Collet chuck Type ER for collets to ISO 15488 (DIN 6499)

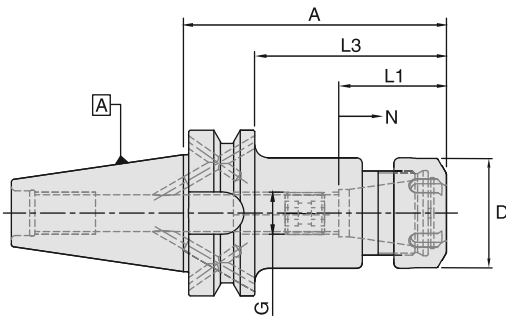

BT50													
Spannzange Collet Type	Bereich Range	D (mm)	D2 (mm)	A (mm)	L1 (mm)	L3 (mm)	L4 (mm)	G (mm)	N	Kühlmittel- zufuhr Coolant supply	N/W (Kg)	Bezeichnung Designation	Ident No.
ER 16	1-10	28	-	70	32.5	32	-	M10	12	Form "AD/B"	3.7	WCCH/ER16-70/BT50	66658852M
ER 20	1-13	34	-	70	38.0	32	-	M12	12	Form "AD/B"	3.8	WCCH/ER20-70/BT50	5062762
ER 25	2-16	42	-	70	41.0	32	-	M16	12	Form "AD/B"	3.7	WCCH/ER25-70/BT50	5062763
ER 32	2-20	50	-	70	47.0	32	-	M22X1.5	12	Form "AD/B"	3.8	WCCH/ER32-70/BT50	5062764
ER 40	3-26	63	-	80	58.5	42	-	M22X1.5	12	Form "AD/B"	4.0	WCCH/ER40-80/BT50	5062765
ER 16	1-10	28	-	100	32.5	62	-	M10	12	Form "AD/B"	3.8	WCCH/ER16-100/BT50	6733403
ER 20	1-13	34	-	100	38.0	62	-	M12	12	Form "AD/B"	3.9	WCCH/ER20-100/BT50	6733405
ER 25	2-16	42	-	100	41.0	62	-	M16	12	Form "AD/B"	3.9	WCCH/ER25-100/BT50	5062405
ER 32	2-20	50	-	100	47.0	62	-	M22X1.5	12	Form "AD/B"	4.1	WCCH/ER32-100/BT50	6733407
ER 40	3-26	63	-	100	58.5	62	-	M22X1.5	12	Form "AD/B"	4.2	WCCH/ER40-100/BT50	6733409
ER 16	1-10	28	-	160	32.5	122	-	M10	12	Form "AD/B"	4.1	WCCH/ER16-160/BT50	5062789
ER 20	1-13	34	-	160	38.0	122	-	M12	12	Form "AD/B"	4.5	WCCH/ER20-160/BT50	5062790
ER 25	2-16	42	-	160	41.0	122	-	M16	12	Form "AD/B"	4.6	WCCH/ER25-160/BT50	5062791
ER 32	2-20	50	-	160	47.0	122	-	M22X1.5	12	Form "AD/B"	4.9	WCCH/ER32-160/BT50	5062792
ER 40	3-26	63	-	160	58.5	122	-	M22X1.5	12	Form "AD/B"	5.0	WCCH/ER40-160/BT50	5062793
ER 25	2-16	42	-	200	41.0	162	-	M16	12	Form "AD"	5.0	WCCH/ER25-200/BT50*	66658661M
ER 32	2-20	50	-	200	47.0	162	-	M22X1.5	12	Form "AD"	5.4	WCCH/ER32-200/BT50*	66658664M
ER 40	3-26	63	-	200	58.5	162	-	M22X1.5	12	Form "AD"	5.5	WCCH/ER40-200/BT50*	66658667M
ER 25	2-16	42	-	250	41.0	212	-	M16	12	Form "AD"	5.4	WCCH/ER25-250/BT50*	66658662M
ER 32	2-20	50	-	250	47.0	212	-	M22X1.5	12	Form "AD"	6.0	WCCH/ER32-250/BT50*	66658665M
ER 40	3-26	63	-	250	58.5	212	-	M22X1.5	12	Form "AD"	6.1	WCCH/ER40-250/BT50*	66658668M
ER 25	2-16	42	42	350	41.0	312	128	M16	12	Form "AD"	8.3	WCCH/ER25-350/BT50*	66658663M
ER 32	2-20	50	50	450	47.0	412	194	M22X1.5	12	Form "AD"	8.4	WCCH/ER32-450/BT50*	66658666M



Ersatzteile und Zubehör / Spare Parts & Accessories: Pg.D20 Pg.D2-D4 Pg.D5 Pg.D7

- Im Lieferumfang enthalten: mit Spannmutter (gewuchtet) und Verstellechraube
- Höhere Wuchtgüte auf Anfrage
- siehe Seite D16-D17 für Drehmomentschlüssel Spezifikationen
- \* Hinweis: Der Rundlauf variiert zwischen 10 und 15 Mikrometer über GPL 200 mm und Wuchtgüte G2.5, 12000 RPM
- Delivery includes: Clamping nut (balanced) & adjusting screw
- Higher balancing grade on request
- Please refer page no.D16-D17 for torque wrench details
- \* Note: For GPL 200mm and above, the run-out will vary between 10-15 microns and the balancing standard is G2.5, 12000 RPM

Spannzangenfutter Typ ER für Spannzangen ISO 15488 (DIN 6499) mit Minimutter  
Collet chuck Type ER for collets to ISO 15488 (DIN 6499) with Mini nut

BT													
Spannzange Collet Type	Bereich Range	D (mm)	A (mm)	L1 (mm)	L3 (mm)	G (mm)	N	Kühlmittelzufuhr Coolant supply	N/W (Kg)	Bezeichnung Designation	Ident No.		
ER 16M	1-10	22	70	33.5	48	M10	12	Form "AD"	0.5	WCCH/ER16M-70/BT30	66658844M		
ER 16M	1-10	22	100	33.5	78	M10	12	Form "AD"	0.6	WCCH/ER16M-100/BT30	66658845M		
ER 16M	1-10	22	70	33.5	43	M10	12	Form "AD/B"	1.0	WCCH/ER16M-70/BT40	66658849M		
ER 16M	1-10	22	100	33.5	73	M10	12	Form "AD/B"	1.2	WCCH/ER16M-100/BT40	66658850M		
ER 16M	1-10	22	160	33.5	133	M10	12	Form "AD/B"	1.5	WCCH/ER16M-160/BT40	66658851M		



# Spannzangenfutter Typ ERC mit interner Kühlung

Collet chuck Type ERC with internal coolant (ER-IC / EX-IC coolant nut)

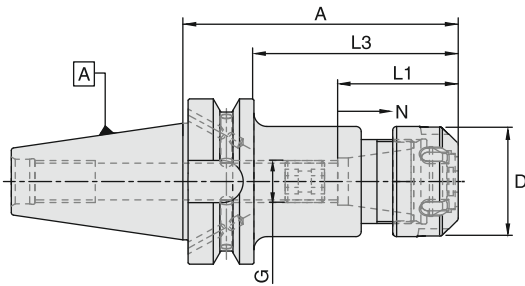

BT30											
Spannzange Collet Type	Bereich Range	D (mm)	A (mm)	L1 (mm)	L3 (mm)	G (mm)	N	Kühlmittelzufuhr Coolant supply	N/W (Kg)	Bezeichnung Designation	Ident No.
ER 16	1-10	28	75	37.5	53	M10	12	Form "AD"	0.7	WCCH/ERC16-75/BT30	5104129
ER 20	1-13	34	75	43.0	53	M12	12	Form "AD"	0.9	WCCH/ERC20-75/BT30	5104130
ER 25	2-16	42	75	46.0	53	M12	12	Form "AD"	0.6	WCCH/ERC25-75/BT30	5104131
ER 32	2-20	50	75	52.0	53	M12	12	Form "AD"	0.8	WCCH/ERC32-75/BT30	5104132
ER 16	1-10	28	105	37.5	83	M10	12	Form "AD"	0.7	WCCH/ERC16-105/BT30	5104134
ER 20	1-13	34	105	43.0	83	M12	12	Form "AD"	1.3	WCCH/ERC20-105/BT30	5104136
ER 25	2-16	42	105	46.0	83	M12	12	Form "AD"	0.6	WCCH/ERC25-105/BT30	5104137

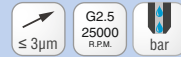

BT40											
Spannzange Collet Type	Bereich Range	D (mm)	A (mm)	L1 (mm)	L3 (mm)	G (mm)	N	Kühlmittelzufuhr Coolant supply	N/W (Kg)	Bezeichnung Designation	Ident No.
ER 16	1-10	28	75	37.5	48	M10	12	Form "AD/B"	1.0	WCCH/ERC16-75/BT40	5104138
ER 20	1-13	34	75	43.0	48	M12	12	Form "AD/B"	1.2	WCCH/ERC20-75/BT40	5104139
ER 25	2-16	42	75	46.0	48	M16	12	Form "AD/B"	1.0	WCCH/ERC25-75/BT40	5104141
ER 32	2-20	50	75	52.0	48	M22X1.5	12	Form "AD/B"	1.2	WCCH/ERC32-75/BT40	5104142
ER 40	3-26	63	85	63.5	58	M22X1.5	12	Form "AD/B"	1.2	WCCH/ERC40-85/BT40	5104143
ER 16	1-10	28	105	37.5	78	M10	12	Form "AD/B"	1.2	WCCH/ERC16-105/BT40	5104144
ER 20	1-13	34	105	43.0	78	M12	12	Form "AD/B"	1.4	WCCH/ERC20-105/BT40	5104145
ER 25	2-16	42	105	46.0	78	M16	12	Form "AD/B"	1.4	WCCH/ERC25-105/BT40	5104146
ER 32	2-20	50	105	52.0	78	M22X1.5	12	Form "AD/B"	1.5	WCCH/ERC32-105/BT40	5104147
ER 40	3-26	63	105	63.5	78	M22X1.5	12	Form "AD/B"	1.8	WCCH/ERC40-105/BT40	5104148
ER 16	1-10	28	165	37.5	138	M10	12	Form "AD/B"	1.6	WCCH/ERC16-165/BT40	5104149
ER 20	1-13	34	165	43.0	138	M12	12	Form "AD/B"	1.6	WCCH/ERC20-165/BT40	5104150
ER 25	2-16	42	165	46.0	138	M16	12	Form "AD/B"	2.1	WCCH/ERC25-165/BT40	5104151
ER 32	2-20	50	165	52.0	138	M22X1.5	12	Form "AD/B"	2.5	WCCH/ERC32-165/BT40	5104153
ER 40	3-26	63	165	63.5	138	M22X1.5	12	Form "AD/B"	2.6	WCCH/ERC40-165/BT40	5104154



Ersatzteile und Zubehör / Spare Parts & Accessories: Pg.D20 Pg.D2-D4 Pg.D5 Pg.D7

- Im Lieferumfang enthalten: Spannmutter (gewuchtet) und Einstellschraube
- Höhere Wuchtgüte auf Anfrage
- siehe Seite D16-D17 für Drehmomentschlüssel Spezifikationen
- ❖ Für WCCH/ERC16-165/BT40, D2=43.2mm & L2=60.5mm

- Delivery includes: Clamping nut (balanced) & adjusting screw
- Higher balancing grade on request
- Please refer page no.D16-D17 for torque wrench details
- ❖ Note: For WCCH/ERC16-165/BT40, D2=43.2mm & L4=60.5mm



Spannzangenfutter Typ ERC mit interner Kühlung  
Collet chuck Type ERC with internal coolant (ER-IC / EX-IC coolant nut)

BT MAS 403  
ISO7388-2

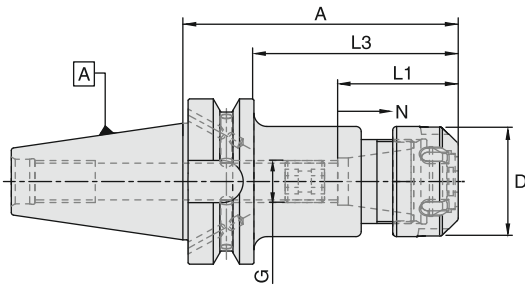

SK DIN 69871  
ISO7388-1

BT50

Spannzange Collet Type	Bereich Range	D (mm)	A (mm)	L1 (mm)	L3 (mm)	G (mm)	N	Kühlmittelzufuhr Coolant supply	N/W (Kg)	Bezeichnung Designation	Ident No.
ER 20	1-13	34	75	43.0	37	M12	12	Form "AD/B"	4.0	WCCH/ERC20-75/BT50	5104236
ER 25	2-16	42	75	46.0	37	M16	12	Form "AD/B"	3.4	WCCH/ERC25-75/BT50	5104237
ER 32	2-20	50	75	52.0	37	M22X1.5	12	Form "AD/B"	3.5	WCCH/ERC32-75/BT50	5104238
ER 40	3-26	63	85	63.5	47	M22X1.5	12	Form "AD/B"	3.6	WCCH/ERC40-85/BT50	5104239
ER 16	1-10	28	105	37.5	67	M10	12	Form "AD/B"	3.6	WCCH/ERC16-105/BT50	5104240
ER 20	1-13	34	105	43.0	67	M12	12	Form "AD/B"	4.0	WCCH/ERC20-105/BT50	5104241
ER 25	2-16	42	105	46.0	67	M16	12	Form "AD/B"	3.8	WCCH/ERC25-105/BT50	5104242
ER 32	2-20	50	105	52.0	67	M22X1.5	12	Form "AD/B"	3.9	WCCH/ERC32-105/BT50	5104243
ER 40	3-26	63	105	63.5	67	M22X1.5	12	Form "AD/B"	3.8	WCCH/ERC40-105/BT50	5104244
ER 16	1-10	28	165	37.5	127	M10	12	Form "AD/B"	4.1	WCCH/ERC16-165/BT50	5104245
ER 20	1-13	34	165	43.0	127	M12	12	Form "AD/B"	4.1	WCCH/ERC20-165/BT50	5104246
ER 25	2-16	42	165	46.0	127	M16	12	Form "AD/B"	4.1	WCCH/ERC25-165/BT50	5104247
ER 32	2-20	50	165	52.0	127	M22X1.5	12	Form "AD/B"	4.6	WCCH/ERC32-165/BT50	5104248
ER 40	3-26	63	165	63.5	127	M22X1.5	12	Form "AD/B"	4.6	WCCH/ERC40-165/BT50	5104249

HSK DIN 69893

Ersatzteile und Zubehör / Spare Parts & Accessories: Pg.D20 Pg.D2-D4 Pg.D5 Pg.D7

- Im Lieferumfang enthalten: mit Spannmutter (gewuchtet) und Verstellechraube
- Höhere Wuchtgüte auf Anfrage
- siehe Seite D16-D17 für Drehmomentschlüssel Spezifikationen
- Delivery includes: Clamping nut (balanced) & adjusting screw
- Higher balancing grade on request
- Please refer page no.D16-D17 for torque wrench details

Zubehör  
Accessories

Ersatzteile  
Spare Parts

Technische Spezifikationen  
Technical Details

# Super collet Spannzangenfutter

## Super collet chuck

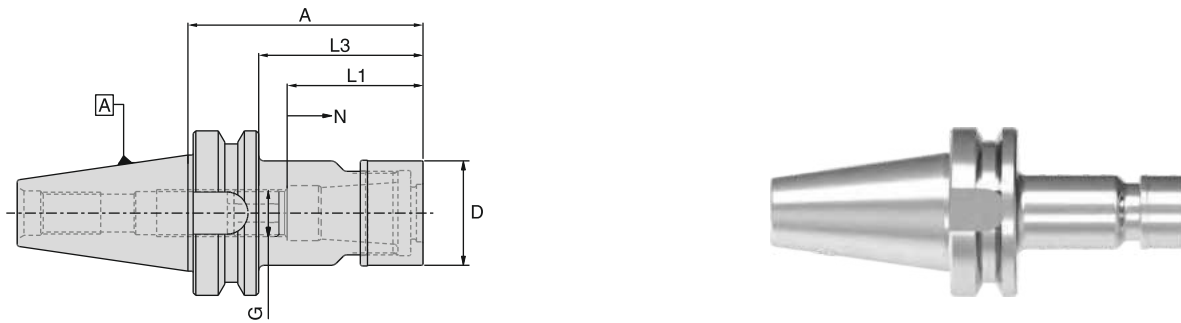

BT30											≤ 2µm	G2.5 25000 RPM	bar
Spannzange Collet Type	Bereich Range	D (mm)	A (mm)	L1 (mm)	L3 (mm)	G (mm)	N (mm)	Kühlmittelzufuhr Coolant supply	N/W (Kg)	Bezeichnung Designation	Ident No.		
SC06	2-6	19.5	60	31.5	38	M8 x1	12	Form "AD"	0,53	WSCH/SCF06-60/BT30	5100405		
SC06	2-6	19.5	90	31.5	68	M8 x1	12	Form "AD"	0,56	WSCH/SCF06-90/BT30	5100407		
SC10	2-10	27.1	60	35.0	38	M12 x1	12	Form "AD"	0,60	WSCH/SCF10-60/BT30	5100408		
SC10	2-10	27.1	90	35.0	68	M12 x1	12	Form "AD"	0,62	WSCH/SCF10-90/BT30	5100416		
SC13	3-13	33.0	60	43.0	38	M15 x1	16	Form "AD"	0,62	WSCH/SCF13-60/BT30	5100420		
SC13	3-13	33.0	90	43.0	68	M15 x1	16	Form "AD"	0,75	WSCH/SCF13-90/BT30	5100421		
SC16	3-16	40.0	60	52.0	38	M12 x1	16	Form "AD"	0,65	WSCH/SCF16-60/BT30	5100423		
SC16	3-16	40.0	90	52.0	68	M18 x1	16	Form "AD"	0,90	WSCH/SCF16-90/BT30	5100425		
SC20	6-20	48.0	60	59.5	38	M18 x1	16	Form "AD"	0,70	WSCH/SCF20-60/BT30	5100426		
SC20	6-20	48.0	90	59.5	68	M22 x1	16	Form "AD"	0,90	WSCH/SCF20-90/BT30	5100427		
SC25	6-25	55.0	90	63.5	68	M28 x1	20	Form "AD"	1,15	WSCH/SCF25-90/BT30	5100429		

BT40											≤ 2µm	G2.5 25000 RPM	bar
Spannzange Collet Type	Bereich Range	D (mm)	A (mm)	L1 (mm)	L3 (mm)	G (mm)	N (mm)	Kühlmittelzufuhr Coolant supply	N/W (Kg)	Bezeichnung Designation	Ident No.		
SC06	2-6	19.5	90	31.5	63	M8 x1	12	Form "AD"	1,10	WSCH/SCF06-90/BT40	5100431		
SC06	2-6	19.5	120	31.5	93	M8 x1	12	Form "AD"	1,20	WSCH/SCF06-120/BT40	5100434		
SC06	2-6	19.5	150	31.5	123	M8 x1	12	Form "AD"	1,25	WSCH/SCF06-150/BT40	5100435		
SC10	2-10	27.1	90	35.0	63	M12 x1	12	Form "AD"	1,20	WSCH/SCF10-90/BT40	5100436		
SC10	2-10	27.1	120	35.0	93	M12 x1	12	Form "AD"	1,35	WSCH/SCF10-120/BT40	5100437		
SC10	2-10	27.1	150	35.0	123	M12 x1	12	Form "AD"	1,45	WSCH/SCF10-150/BT40	5100439		
SC13	3-13	33.0	90	43.0	63	M15 x1	16	Form "AD"	1,40	WSCH/SCF13-90/BT40	5100441		
SC13	3-13	33.0	120	43.0	93	M15 x1	16	Form "AD"	1,50	WSCH/SCF13-120/BT40	5100442		
SC13	3-13	33.0	150	43.0	123	M15 x1	16	Form "AD"	1,71	WSCH/SCF13-150/BT40	5100443		
SC16	3-16	40.0	90	52.0	63	M18 x1	16	Form "AD"	1,50	WSCH/SCF16-90/BT40	5100444		
SC16	3-16	40.0	120	52.0	93	M18 x1	16	Form "AD"	1,70	WSCH/SCF16-120/BT40	5100446		
SC16	3-16	40.0	150	52.0	123	M18 x1	16	Form "AD"	2,00	WSCH/SCF16-150/BT40	5100447		
SC20	6-20	48.0	90	59.5	63	M22 x1	16	Form "AD"	1,41	WSCH/SCF20-90/BT40	5100448		
SC20	6-20	48.0	120	59.5	93	M22 x1	16	Form "AD"	2,01	WSCH/SCF20-120/BT40	5100449		
SC20	6-20	48.0	150	59.5	123	M22 x1	16	Form "AD"	2,45	WSCH/SCF20-150/BT40	5100450		
SC25	6-25	55.0	90	63.5	63	M28 x1	20	Form "AD"	1,55	WSCH/SCF25-90/BT40	5100452		
SC25	6-25	55.0	120	63.5	93	M28 x1	20	Form "AD"	2,20	WSCH/SCF25-120/BT40	5100453		
SC25	6-25	55.0	150	63.5	123	M28 x1	20	Form "AD"	2,70	WSCH/SCF25-150/BT40	5100456		

Ersatzteile und Zubehör / Spare Parts & Accessories: Pg.D8-D9 Pg.D10 Pg.D9 Pg.D20

• Im Lieferumfang enthalten: mit Spannmutter (gewuchtet) und Verstellechraube • Delivery includes: Clamping nut (friction type), Adjusting screw

Technische Details siehe Seite F6-F7 / For technical details please refer the instruction manual provided in the packing box or refer page F6-F7

# Super collet Spannzangenfutter

## Super collet chuck

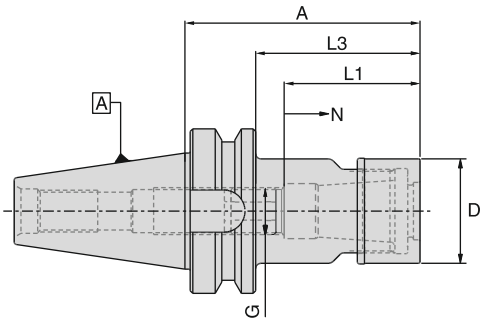

BT50													
Spannzange Collet Type	Bereich Range	D (mm)	A (mm)	L1 (mm)	L3 (mm)	G (mm)	N (mm)	Kühlmittelzufuhr Coolant supply	N/W (Kg)	Bezeichnung Designation	Ident No.		
SC06	2-6	19.5	105	31.5	67	M8 x1	12	Form "AD"	3,70	WSCH/SCF06-105/BT50	5100457		
SC06	2-6	19.5	135	31.5	97	M8 x1	12	Form "AD"	3,80	WSCH/SCF06-135/BT50	5100458		
SC06	2-6	19.5	165	31.5	127	M8 x1	12	Form "AD"	3,85	WSCH/SCF06-165/BT50	5100459		
SC10	2-10	27.1	105	35.0	67	M12 x1	12	Form "AD"	3,85	WSCH/SCF10-105/BT50	5100460		
SC10	2-10	27.1	135	35.0	97	M12 x1	12	Form "AD"	3,92	WSCH/SCF10-135/BT50	5100461		
SC10	2-10	27.1	165	35.0	127	M12 x1	12	Form "AD"	4,10	WSCH/SCF10-165/BT50	5100462		
SC13	3-13	33.0	105	43.0	67	M15 x1	16	Form "AD"	4,10	WSCH/SCF13-105/BT50	5101997		
SC13	3-13	33.0	135	43.0	97	M15 x1	16	Form "AD"	4,20	WSCH/SCF13-135/BT50	5101998		
SC13	3-13	33.0	165	43.0	127	M15 x1	16	Form "AD"	4,35	WSCH/SCF13-165/BT50	5101999		
SC16	3-16	40.0	105	52.0	67	M18 x1.5	16	Form "AD"	4,10	WSCH/SCF16-105/BT50	5102000		
SC16	3-16	40.0	135	52.0	97	M18 x1.5	16	Form "AD"	4,30	WSCH/SCF16-135/BT50	5102001		
SC16	3-16	40.0	165	52.0	127	M18 x1.5	16	Form "AD"	4,50	WSCH/SCF16-165/BT50	5102002		
SC20	6-20	48.0	105	59.5	67	M22 x1.5	16	Form "AD"	4,30	WSCH/SCF20-105/BT50	5102003		
SC20	6-20	48.0	135	59.5	97	M22 x1.5	16	Form "AD"	4,65	WSCH/SCF20-135/BT50	5102004		
SC20	6-20	48.0	165	59.5	127	M22 x1.5	16	Form "AD"	5,00	WSCH/SCF20-165/BT50	5102005		
SC25	6-25	55.0	105	63.5	67	M28 x1.5	20	Form "AD"	4,30	WSCH/SCF25-105/BT50	5102006		
SC25	6-25	55.0	135	63.5	97	M28 x1.5	20	Form "AD"	4,80	WSCH/SCF25-135/BT50	5102007		
SC25	6-25	55.0	165	63.5	127	M28 x1.5	20	Form "AD"	5,30	WSCH/SCF25-165/BT50	5102008		

Ersatzteile und Zubehör / Spare Parts & Accessories: Pg.D8-D9 Pg.D10 Pg.D9 Pg.D20

• Im Lieferumfang enthalten: mit Spannmutter (gewuchtet) und Verstelle schraube • Delivery includes: Clamping nut (friction type), Adjusting screw

Technische Details siehe Seite F6-F7 / For technical details please refer the instruction manual provided in the packing box or refer page F6-F7

Fräseraufnahmen (Weldon) - für Zylinderschäfte gemäß DIN 1835B  
 End mill holder (Weldon) - For cylindrical shanks according to DIN 1835B

BT MAS 403  
 ISO7388-2

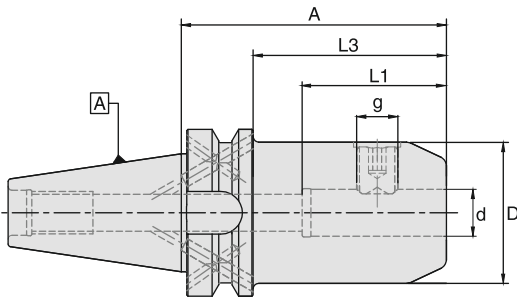

BT30									

d (mm)	D (mm)	A (mm)	L1 (mm)	L3 (mm)	g	Kühlmittelzufuhr Coolant supply	N/W (Kg)	Bezeichnung Designation	Ident No.
06	25	50	37.0	28	M6	Form "AD"	0.50	WSLH/06-50/BT30	4600586
08	28	50	37.0	28	M8	Form "AD"	0.50	WSLH/08-50/BT30	4600587
10	35	50	41.0	28	M10	Form "AD"	0.60	WSLH/10-50/BT30	4600588
12	42	50	46.0	28	M12	Form "AD"	0.65	WSLH/12-50/BT30	4600589
14	44	50	46.0	28	M12	Form "AD"	0.65	WSLH/14-50/BT30	4600590
16	48	63	49.0	41	M14	Form "AD"	0.90	WSLH/16-63/BT30	4600591
18	50	63	49.0	41	M14	Form "AD"	0.95	WSLH/18-63/BT30	4600592
20	52	63	51.0	41	M16	Form "AD"	0.95	WSLH/20-63/BT30	5050529
25	65	90	59.0	61	M18 x2	Form "AD"	1.70	WSLH/25-90/BT30	66658866M

BT40									
------	--	--	--	--	--	--	--	--	--

d (mm)	D (mm)	A (mm)	L1 (mm)	L3 (mm)	g	Kühlmittelzufuhr Coolant supply	N/W (Kg)	Bezeichnung Designation	Ident No.
16	48	35	49.0	8	M14	Form "AD"	1.05	WSLH/16-35/BT40*	5062796
20	52	35	51.0	8	M16	Form "AD"	1.10	WSLH/20-35/BT40*	5062797
25	45	35	59.0	8	M16	Form "AD"	1.00	WSLH/25-35/BT40*	5062798
32	63	65	63.0	38	M20 x2	Form "AD"	1.50	WSLH/32-65/BT40*	5062799
06	25	50	37.0	23	M6	Form "AD/B"	1.02	WSLH/06-50/BT40	5062843
08	28	50	37.0	23	M8	Form "AD/B"	1.10	WSLH/08-50/BT40	5062846
10	35	63	41.0	36	M10	Form "AD/B"	1.25	WSLH/10-63/BT40	5062847
12	42	63	46.0	36	M12	Form "AD/B"	1.30	WSLH/12-63/BT40	5062848
14	44	63	46.0	36	M12	Form "AD/B"	1.30	WSLH/14-63/BT40	5062849
16	48	63	49.0	36	M14	Form "AD/B"	1.40	WSLH/16-63/BT40	5062851
18	50	63	49.0	36	M14	Form "AD/B"	1.40	WSLH/18-63/BT40	5062852
20	52	63	51.0	36	M16	Form "AD/B"	1.50	WSLH/20-63/BT40	5062853
25	65	90	59.0	63	M18 x2	Form "AD/B"	2.20	WSLH/25-90/BT40 **	5062856
32	72	100	63.0	73	M20 x2	Form "AD/B"	2.70	WSLH/32-100/BT40 **	5062883
40	80	120	73.0	93	M20 x2	Form "AD/B"	3.55	WSLH/40-120/BT40 **	5062884
06	25	100	37.0	73	M6	Form "AD/B"	1.22	WSLH/06-100/BT40	5062897
08	28	100	37.0	73	M8	Form "AD/B"	1.30	WSLH/08-100/BT40	5062898
10	35	100	41.0	73	M10	Form "AD/B"	1.50	WSLH/10-100/BT40	5062899
12	42	100	46.0	73	M12	Form "AD/B"	1.70	WSLH/12-100/BT40	5062900
14	44	100	46.0	73	M12	Form "AD/B"	1.70	WSLH/14-100/BT40	5062901
16	48	100	49.0	73	M14	Form "AD/B"	1.85	WSLH/16-100/BT40	5062902
18	50	100	49.0	73	M14	Form "AD/B"	1.90	WSLH/18-100/BT40	5062903
20	52	100	51.0	73	M16	Form "AD/B"	2.00	WSLH/20-100/BT40	5062904
06	25	160	37.0	133	M6	Form "AD/B"	1.60	WSLH/06-160/BT40 ❖	5063409
08	28	160	37.0	133	M8	Form "AD/B"	1.75	WSLH/08-160/BT40 ❖	5063412
10	35	160	41.0	133	M10	Form "AD/B"	2.05	WSLH/10-160/BT40 ❖	5063413
12	42	160	46.0	133	M12	Form "AD/B"	2.30	WSLH/12-160/BT40	5063414
14	44	160	46.0	133	M12	Form "AD/B"	2.40	WSLH/14-160/BT40	5063415
16	48	160	49.0	133	M14	Form "AD/B"	2.70	WSLH/16-160/BT40	5063416
18	50	160	49.0	133	M14	Form "AD/B"	2.80	WSLH/18-160/BT40	5063417
20	52	160	51.0	133	M16	Form "AD/B"	2.90	WSLH/20-160/BT40	5063418
25	65	160	59.0	133	M18 x2	Form "AD/B"	4.00	WSLH/25-160/BT40 **	5063419
32	72	160	63.0	125	M20 x2	Form "AD/B"	4.50	WSLH/32-160/BT40 **	66658867M

SK DIN 69871  
 ISO7388-1

HSK DIN 69893

Zubehör  
 Accessories

Ersatzteile  
 Spare Parts

Technische Spezifikationen  
 Technical Details

Fräseraufnahmen (Weldon) - für Zylinderschäfte gemäß DIN 1835B  
 End mill holder (Weldon) - For cylindrical shanks according to DIN 1835B

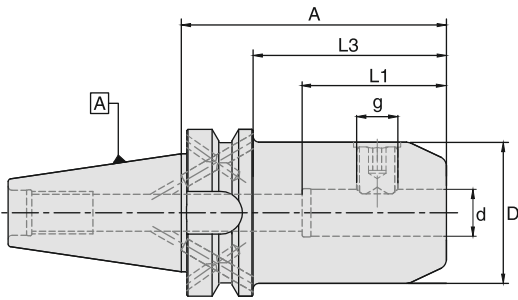

BT50									
d (mm)	D (mm)	A (mm)	L1 (mm)	L3 (mm)	g	Kühlmittelzufuhr Coolant supply	N/W (Kg)	Bezeichnung Designation	Ident No.
06	25	63	37	25	M6	Form "AD/B"	3.70	WSLH/06-63/BT50	5063475
08	28	63	37	25	M8	Form "AD/B"	3.70	WSLH/08-63/BT50	5063476
10	35	63	41	25	M10	Form "AD/B"	3.80	WSLH/10-63/BT50	5063477
12	42	80	46	42	M12	Form "AD/B"	4.00	WSLH/12-80/BT50	5063478
14	44	80	46	42	M12	Form "AD/B"	4.00	WSLH/14-80/BT50	5063486
16	48	80	49	42	M14	Form "AD/B"	4.05	WSLH/16-80/BT50	5063487
18	50	80	49	42	M14	Form "AD/B"	4.10	WSLH/18-80/BT50	5063489
20	52	80	51	42	M16	Form "AD/B"	4.15	WSLH/20-80/BT50	5063491
25	65	100	59	62	M18 x2	Form "AD/B"	4.80	WSLH/25-100/BT50 **	5063492
32	72	105	63	67	M20 x2	Form "AD/B"	5.15	WSLH/32-105/BT50 **	5063493
40	80	110	73	72	M20 x2	Form "AD/B"	5.50	WSLH/40-110/BT50 **	5063494
06	25	100	37	62	M6	Form "AD/B"	3.80	WSLH/06-100/BT50	5063549
08	28	100	37	62	M8	Form "AD/B"	3.85	WSLH/08-100/BT50	5063550
10	35	100	41	62	M10	Form "AD/B"	3.95	WSLH/10-100/BT50	5063551
12	42	100	46	62	M12	Form "AD/B"	4.15	WSLH/12-100/BT50	5063552
14	44	100	46	62	M12	Form "AD/B"	4.25	WSLH/14-100/BT50	5063553
16	48	100	49	62	M14	Form "AD/B"	4.35	WSLH/16-100/BT50	5063554
18	50	100	49	62	M14	Form "AD/B"	4.40	WSLH/18-100/BT50	5063555
20	52	100	51	62	M16	Form "AD/B"	4.40	WSLH/20-100/BT50	5063556
06	25	160	37	122	M6	Form "AD/B"	4.10	WSLH/06-160/BT50 ❖	5063560
08	28	160	37	122	M8	Form "AD/B"	4.25	WSLH/08-160/BT50 ❖	5063561
10	35	160	41	122	M10	Form "AD/B"	4.60	WSLH/10-160/BT50 ❖	5063562
12	42	160	46	122	M12	Form "AD/B"	4.80	WSLH/12-160/BT50	5063565
14	44	160	46	122	M12	Form "AD/B"	4.90	WSLH/14-160/BT50	5063566
16	48	160	49	122	M14	Form "AD/B"	5.15	WSLH/16-160/BT50	5063567
18	50	160	49	122	M14	Form "AD/B"	5.25	WSLH/18-160/BT50	5063568
20	52	160	51	122	M16	Form "AD/B"	5.40	WSLH/20-160/BT50	5063569
25	65	160	59	122	M18 x2	Form "AD/B"	6.25	WSLH/25-160/BT50 **	5063570
32	72	160	63	122	M20 x2	Form "AD/B"	6.80	WSLH/32-160/BT50 **	5063571
25	65	200	59	162	M18 x2	Form "AD"	7.05	WSLH/25-200/BT50 **	66658676M
32	72	200	63	162	M20 x2	Form "AD"	7.85	WSLH/32-200/BT50 **	66658678M
25	65	250	59	212	M18 x2	Form "AD"	8.20	WSLH/25-250/BT50 **	66658677M
32	72	250	63	212	M20 x2	Form "AD"	9.10	WSLH/32-250/BT50 **	66658679M
32	72	450	63	412	M20 x2	Form "AD"	15.85	WSLH/32-450/BT50 **	66658680M



Ersatzteile und Zubehör / Spare Parts & Accessories: Pg.D20 Pg.E2

- \*\* 2 Spanschrauben für ID Größe = 25 / 32 / 40
- \* Extra kurze Aufnahmen: Die Spanschrauben sind im Mitnehmer, Maximale Steifigkeit dank kurzer Ausraglänge
- Bohrungstoleranz H4
- Im Lieferumfang enthalten: Spanschraube
- Höhere Wuchtgüte auf Anfrage
- \* Hinweis: Der Rundlauf variiert zwischen 10 und 15 Mikrometer über GPL 200 mm

❖ Für..

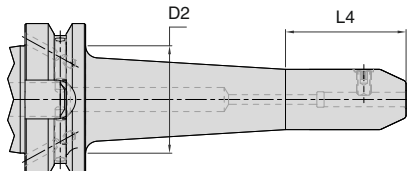

- \*\* 2 locking screws for ID size = 25 / 32 / 40 | • Bore tolerance H4
- \* Extra short holders: Locking screws are located in the same place as drive slots | Gives maximum rigidity due to short projection
- Delivery includes: Locking screw
- Higher balancing grade on request
- \* Note: For GPL 200mm and above, the run-out will vary between 10-15 microns and the balancing standard is G2.5, 12000 RPM
- ❖ For WSLH/06-160/BT40, D2=44.6mm & L4=50mm
- For WSLH/10-160/BT40, D2=53.3mm & L4=60mm
- For WSLH/08-160/BT40, D2=47.6mm & L4=50mm
- For WSLH/06-160/BT50, D2=39.5mm & L4=50mm
- For WSLH/08-160/BT50, D2=42.4mm & L4=50mm
- For WSLH/10-160/BT50, D2=49.4mm & L4=50mm

Fräseraufnahmen DIN 6359 mit Kühlkanal (für Zylinderschäfte gemäß DIN 1835 B)  
 End mill holder to DIN 6359 with coolant channel (For cylindrical shanks according to DIN 1835B)

BT MAS 403  
ISO7388-2

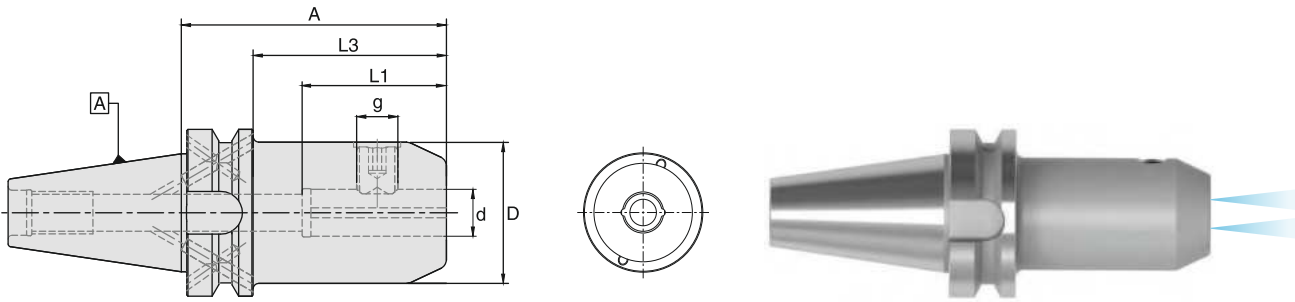

BT40									
d (mm)	D (mm)	A (mm)	L1 (mm)	L3 (mm)	g	Kühlmittelzufuhr Coolant supply	N/W (Kg)	Bezeichnung Designation	Ident No.
16	48	35	49	8	M14	Form "AD"	1.05	WSLH-K/16-35/BT40*	5063572
20	52	35	51	8	M16	Form "AD"	1.10	WSLH-K/20-35/BT40*	5063573
25	45	35	59	8	M16	Form "AD"	1.00	WSLH-K/25-35/BT40*	5063574
32	63	65	63	38	M20 x2	Form "AD"	1.50	WSLH-K/32-65/BT40*	5063575
06	25	50	37	23	M6	Form "AD/B"	1.02	WSLH-K/06-50/BT40	5063576
08	28	50	37	23	M8	Form "AD/B"	1.10	WSLH-K/08-50/BT40	5063577
10	35	63	41	36	M10	Form "AD/B"	1.25	WSLH-K/10-63/BT40	5063578
12	42	63	46	36	M12	Form "AD/B"	1.30	WSLH-K/12-63/BT40	5063579
14	44	63	46	36	M12	Form "AD/B"	1.30	WSLH-K/14-63/BT40	5063580
16	48	63	49	36	M14	Form "AD/B"	1.40	WSLH-K/16-63/BT40	5063581
18	50	63	49	36	M14	Form "AD/B"	1.40	WSLH-K/18-63/BT40	5063582
20	52	63	51	36	M16	Form "AD/B"	1.50	WSLH-K/20-63/BT40	5063583
25	65	90	59	63	M18 x2	Form "AD/B"	2.20	WSLH-K/25-90/BT40 **	5063666
32	72	100	63	73	M20 x2	Form "AD/B"	2.70	WSLH-K/32-100/BT40 **	5063667
40	80	120	73	93	M20 x2	Form "AD/B"	3.55	WSLH-K/40-120/BT40 **	5063668

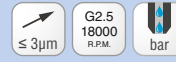

SK DIN 69871  
ISO7388-1

HSK DIN 69893

BT50									
d (mm)	D (mm)	A (mm)	L1 (mm)	L3 (mm)	g	Kühlmittelzufuhr Coolant supply	N/W (Kg)	Bezeichnung Designation	Ident No.
06	25	63	37	25	M6	Form "AD/B"	3.70	WSLH-K/06-63/BT50	5063686
08	28	63	37	25	M8	Form "AD/B"	3.70	WSLH-K/08-63/BT50	5063687
10	35	63	41	25	M10	Form "AD/B"	3.80	WSLH-K/10-63/BT50	5063688
12	42	80	46	42	M12	Form "AD/B"	4.00	WSLH-K/12-80/BT50	5063689
14	44	80	46	42	M12	Form "AD/B"	4.00	WSLH-K/14-80/BT50	5063690
16	48	80	49	42	M14	Form "AD/B"	4.05	WSLH-K/16-80/BT50	5063691
18	50	80	49	42	M14	Form "AD/B"	4.10	WSLH-K/18-80/BT50	5063692
20	52	80	51	42	M16	Form "AD/B"	4.15	WSLH-K/20-80/BT50	5063693
25	65	100	59	62	M18 x2	Form "AD/B"	4.80	WSLH-K/25-100/BT50 **	5063694
32	72	105	63	67	M20 x2	Form "AD/B"	5.15	WSLH-K/32-105/BT50 **	5063695
40	80	110	73	72	M20 x2	Form "AD/B"	5.50	WSLH-K/40-110/BT50 **	5063696



Zubehör  
Accessories

Ersatzteile  
Spare Parts

Ersatzteile und Zubehör / Spare Parts & Accessories: Pg.D20 Pg.E2

- Bohrungstoleranz H4
- Mit 2 Kühlkanälen entlang der Aufnahmebohrung versehen
- \*\* 2 Spannschrauben für ID Größe = 25 / 32 / 40
- \* Extra kurze Aufnahmen:
- Die Spannschrauben sind im Mitnehmer
- Maximale Steifigkeit dank kurzer Auskraglänge
- Im Lieferumfang enthalten: Spannschraube
- Höhere Wuchtgüte auf Anfrage

- Bore tolerance H4
- With two coolant channels along the side of the bore
- \*\* 2 locking screws for ID size = 25 / 32 / 40
- \* Extra short holders:
- Locking screws are located in the same plane as drive slots
- Gives maximum rigidity due to short projection.
- Delivery includes: Locking screw
- Higher balancing grade on request

Technische Spezifikationen  
Technical Details

Fräseraufnahmen DIN 6359 Whistle Notch (für Zylinderschäfte gemäß DIN 1835 E)

End mill holder to DIN 6359 Whistle Notch (For cylindrical shanks according to DIN 1835 E)

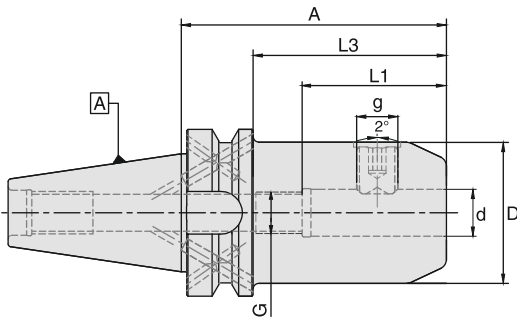

BT40										
d (mm)	D (mm)	A (mm)	L1 (mm)	L3 (mm)	G	g	Kühlmittelezufuhr Coolant supply	N/W (Kg)	Bezeichnung Designation	Ident No.
06	25	50	36.5	23	M5	M6	Form "AD/B"	1.20	WSLH-E/06-50/BT40	5063751
08	28	50	36.5	23	M6	M8	Form "AD/B"	1.20	WSLH-E/08-50/BT40	5063752
10	35	63	40.5	36	M8	M10	Form "AD/B"	1.35	WSLH-E/10-63/BT40	5063753
12	42	63	45.5	36	M10	M12	Form "AD/B"	1.45	WSLH-E/12-63/BT40	5063754
14	44	63	45.5	36	M10	M12	Form "AD/B"	1.45	WSLH-E/14-63/BT40	5063757
16	48	63	48.5	36	M12	M14	Form "AD/B"	1.50	WSLH-E/16-63/BT40	5063758
18	50	63	48.5	36	M12	M14	Form "AD/B"	1.60	WSLH-E/18-63/BT40	5063759
20	52	63	50.5	36	M16	M16	Form "AD/B"	1.60	WSLH-E/20-63/BT40	5063760
25	65	90	56.5	63	M20	M18 x2	Form "AD/B"	2.25	WSLH-E/25-90/BT40 **	5063761
32	72	100	60.5	73	M20	M20 x2	Form "AD/B"	2.75	WSLH-E/32-100/BT40 **	5063762
40	80	120	70.5	93	M20	M20 x2	Form "AD/B"	3.70	WSLH-E/40-120/BT40 **	5063763

BT50										
d (mm)	D (mm)	A (mm)	L1 (mm)	L3 (mm)	G	g	Kühlmittelezufuhr Coolant supply	N/W (Kg)	Bezeichnung Designation	Ident No.
06	25	63	36.5	25	M5	M6	Form "AD/B"	3.80	WSLH-E/06-63/BT50	4601432
08	28	63	36.5	25	M6	M8	Form "AD/B"	3.80	WSLH-E/08-63/BT50	4601433
10	35	63	40.5	25	M8	M10	Form "AD/B"	3.85	WSLH-E/10-63/BT50	4601434
12	42	80	45.5	42	M10	M12	Form "AD/B"	4.05	WSLH-E/12-80/BT50	4601435
14	44	80	45.5	42	M10	M12	Form "AD/B"	4.10	WSLH-E/14-80/BT50	4601436
16	48	80	48.5	42	M12	M14	Form "AD/B"	4.10	WSLH-E/16-80/BT50	4601437
18	50	80	48.5	42	M12	M14	Form "AD/B"	4.20	WSLH-E/18-80/BT50	4601438
20	52	80	50.5	42	M16	M16	Form "AD/B"	4.25	WSLH-E/20-80/BT50	4601439
25	65	100	56.5	62	M20	M18 x2	Form "AD/B"	5.00	WSLH-E/25-100/BT50 **	4601440
32	72	105	60.5	67	M20	M20 x2	Form "AD/B"	5.30	WSLH-E/32-105/BT50 **	4601441
40	80	115	70.5	77	M20	M20 x2	Form "AD/B"	5.90	WSLH-E/40-115/BT50 **	5064367

Ersatzteile und Zubehör / Spare Parts & Accessories: Pg.D20 Pg.E2

- Bohrungstoleranz H4
- Stirnseitige Nut als Erkennungsmerkmal (im Unterschied zu Weldon)
- Im Lieferumfang enthalten: Spannschraube und Verstellerschraube
- Höhere Wuchtgüte auf Anfrage
- Bore tolerance H4
- \*\* 2 locking screws for ID size = 25 / 32 / 40
- Groove on face for easy identification (to distinguish from Weldon)
- Delivery includes: Locking screw & adjusting screw
- Higher balancing grade on request

# Hochleistungsfräaserspannfutter

## Hi-Power Milling Chuck

BT MAS 403  
ISO7388-2

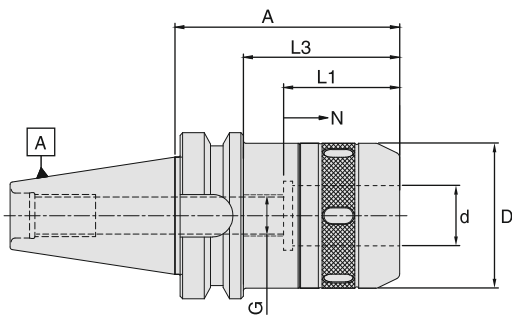

BT30										
d (mm)	D (mm)	A (mm)	L1 (mm)	L3 (mm)	G	N	Kühlmittelezufuhr Coolant supply	N/W (Kg)	Bezeichnung Designation	Ident No.
20	52	90	60	68	M12x1	15	Form "AD"	1.45	WHPMC/20-90/BT30	5066331
25	58	90	70	68	M12x1	15	Form "AD"	1.55	WHPMC/25-90/BT30	5066332
32	66	105	75	83	M12x1	15	Form "AD"	1.85	WHPMC/32-105/BT30	5066333



SK DIN 69871  
ISO7388-1

BT40										
d (mm)	D (mm)	A (mm)	L1 (mm)	L3 (mm)	G	N	Kühlmittelezufuhr Coolant supply	N/W (Kg)	Bezeichnung Designation	Ident No.
20	52	90	60	63	M12x1	15	Form "AD"	2.35	WHPMC/20-90/BT40	5061428
25	58	90	70	63	M16x1	15	Form "AD"	2.10	WHPMC/25-90/BT40	5065112
32	66	105	75	78	M16x1	15	Form "AD"	2.60	WHPMC/32-105/BT40	5061429

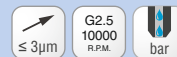

HSK DIN 69893

BT50										
d (mm)	D (mm)	A (mm)	L1 (mm)	L3 (mm)	G	N	Kühlmittelezufuhr Coolant supply	N/W (Kg)	Bezeichnung Designation	Ident No.
20	52	90	60	52	M12x1	15	Form "AD"	5.55	WHPMC/20-90/BT50	5061430
25	58	90	60	52	M16x1	15	Form "AD"	4.55	WHPMC/25-90/BT50	5065113
32	66	105	75	67	M16x1	15	Form "AD"	4.90	WHPMC/32-105/BT50	5061431
20	52	160	60	122	M12x1	15	Form "AD"	6.83	WHPMC/20-160/BT50	66658860M
25	58	160	60	122	M16x1	15	Form "AD"	5.70	WHPMC/25-160/BT50	66658861M
32	66	160	75	122	M16x1	15	Form "AD"	6.28	WHPMC/32-160/BT50	66658862M

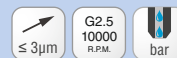

Zubehör  
Accessories

Ersatzteile und Zubehör / Spare Parts & Accessories: Pg.D12 Pg.D12 Pg.D20

Technische Details siehe Seite F4-F5 / For technical details please refer the instruction manual provided in the packing box or refer page F4-F5

Ersatzteile  
Spare Parts

Technische Spezifikationen  
Technical Details



# Schlanke Hochleistungsfräserspannfutter Slim Hi-Power Milling Chuck

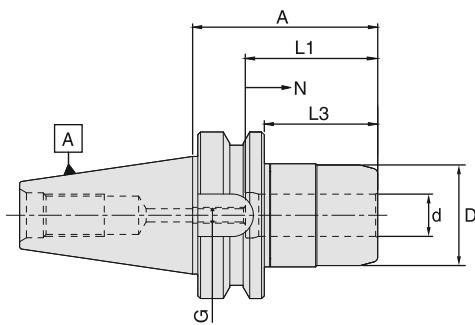

BT30										
d (mm)	D (mm)	A (mm)	L1 (mm)	L3 (mm)	G	N	Kühlmittelezufuhr Coolant Supply	N/W (Kg)	Bezeichnung Designation	Ident No.
6	25	100	36	78	M5	8	Form "AD"	0,90	WHPMC/S06-100/BT30	5105329
8	25	100	36	78	M6	8	Form "AD"	0,90	WHPMC/S08-100/BT30	5105331
10	30	100	42	78	M8x1	8	Form "AD"	0,90	WHPMC/S10-100/BT30	5105332
12	30	70	45	48	M8	8	Form "AD"	0,85	WHPMC/S12-70/BT30	5097447
12	30	120	45	98	M8	8	Form "AD"	1,20	WHPMC/S12-120/BT30	5097450
16	38	70	50	48	M8	10	Form "AD"	0,80	WHPMC/S16-70/BT30	5097451
16	38	120	50	98	M8	10	Form "AD"	1,20	WHPMC/S16-120/BT30	5097452

BT40										
d (mm)	D (mm)	A (mm)	L1 (mm)	L3 (mm)	G	N	Kühlmittelezufuhr Coolant Supply	N/W (Kg)	Bezeichnung Designation	Ident No.
6	25	100	36	73	M5	8	Form "AD"	1,70	WHPMC/S06-100/BT40	5105333
8	25	100	36	73	M6	8	Form "AD"	1,70	WHPMC/S08-100/BT40	5105334
10	30	100	42	73	M8x1	8	Form "AD"	1,70	WHPMC/S10-100/BT40	5105335
12	30	70	45	43	M8	8	Form "AD"	1,55	WHPMC/S12-70/BT40	5097453
12	30	120	45	93	M8	8	Form "AD"	1,85	WHPMC/S12-120/BT40	5097454
16	38	70	50	43	M8	10	Form "AD"	1,45	WHPMC/S16-70/BT40	5097455
16	38	120	50	93	M8	10	Form "AD"	2,20	WHPMC/S16-120/BT40	5097456
20	44	90	55	63	M12x1	10	Form "AD"	2,10	WHPMC/S20-90/BT40	5097459
20	44	150	55	123	M12x1	10	Form "AD"	2,90	WHPMC/S20-150/BT40	5097460

BT50										
d (mm)	D (mm)	A (mm)	L1 (mm)	L3 (mm)	G	N	Kühlmittelezufuhr Coolant Supply	N/W (Kg)	Bezeichnung Designation	Ident No.
12	30	90	45	52	M8	8	Form "AD"	4,95	WHPMC/S12-90/BT50	5097461
12	30	120	45	82	M8	8	Form "AD"	5,15	WHPMC/S12-120/BT50	5097463
16	38	90	50	52	M8	10	Form "AD"	5,20	WHPMC/S16-90/BT50	5097465
16	38	120	50	82	M8	10	Form "AD"	5,35	WHPMC/S16-120/BT50	5097468
20	44	100	55	62	-	10	Form "AD"	5,45	WHPMC/S20-100/BT50	5097471
20	44	150	55	112	M12x1	10	Form "AD"	6,00	WHPMC/S20-150/BT50	5097473

Ersatzteile und Zubehör / Spare Parts & Accessories: Pg.D13 Pg.D13 Pg.D20

Technische Details siehe Seite F4-F5 / For technical details please refer the instruction manual provided in the packing box or refer page F4-F5

Mini-Spannzangenhalter  
Mini collet holder

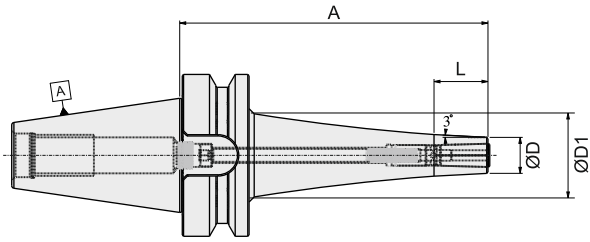

BT30									
Spannzange Collet Type	Bereich Range	A (mm)	L (mm)	D (mm)	D1 (mm)	Kühlmittelzufuhr Coolant supply	N/W (Kg)	Bezeichnung Designation	Ident No.
MC14	3-6	90	21	14	29	-	0,55	WMCH/D14-90/BT30	66658751M
MC14	3-6	120	21	14	33	-	0,67	WMCH/D14-120/BT30	66658752M



BT40									
Spannzange Collet Type	Bereich Range	A (mm)	L (mm)	D (mm)	D1 (mm)	Kühlmittelzufuhr Coolant supply	N/W (Kg)	Bezeichnung Designation	Ident No.
MC14	3-6	90	21.0	14	29.0	-	1,2	WMCH/D14-90/BT40	66658753M
MC14	3-6	120	21.0	14	33.0	-	1,3	WMCH/D14-120/BT40	66658754M
MC14	3-6	150	21.0	14	42.0	-	1,6	WMCH/D14-150/BT40	66658755M
MC21	6-12	90	31.5	21	33.9	-	1,3	WMCH/D21-90/BT40	66658764M
MC21	6-12	120	31.5	21	43.0	-	1,6	WMCH/D21-120/BT40	66658765M
MC21	6-12	150	31.5	21	42.9	-	1,8	WMCH/D21-150/BT40	66658766M



BT50									
Spannzange Collet Type	Bereich Range	A (mm)	L1 (mm)	D (mm)	D1 (mm)	Kühlmittelzufuhr Coolant supply	N/W (Kg)	Bezeichnung Designation	Ident No.
MC14	3-6	90	21.0	14	25.0	-	3,8	WMCH/D14-90/BT50	66658756M
MC14	3-6	120	21.0	14	35.0	-	3,9	WMCH/D14-120/BT50	66658757M
MC14	3-6	150	21.0	14	42.0	-	4,1	WMCH/D14-150/BT50	66658758M
MC21	6-12	90	31.5	21	30.5	-	3,9	WMCH/D21-90/BT50	66658767M
MC21	6-12	120	31.5	21	39.9	-	4,1	WMCH/D21-120/BT50	66658768M
MC21	6-12	150	31.5	21	50.0	-	4,4	WMCH/D21-150/BT50	66658769M



Ersatzteile und Zubehör / Spare Parts & Accessories: Pg.D20 Pg.D16 Pg.D16 Pg.D16

Hydrodehnspannfutter (kurze & verstärkt)  
Hydraulic expansion chuck (short & rigid)

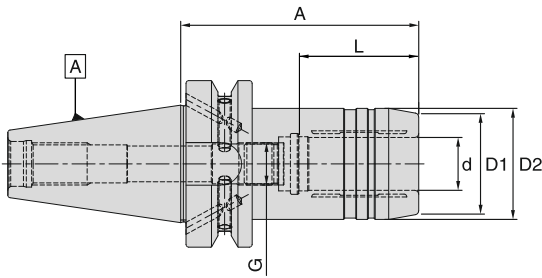

BT30									
d (mm)	A	D1 (mm)	D2 (mm)	L	G	N/W (Kg)	Kühlmittelzufuhr Coolant supply	Bezeichnung Designation	Ident No.
12	69	32	42	41	M8X1.0	0.80	Form "AD"	WHEC-P/12-69/BT30	5159314
20	90	38	42	48	M8X1.0	0.90	Form "AD"	WHEC-P/20-90/BT30	5159315

BT40									
d (mm)	A	D1 (mm)	D2 (mm)	L	G	N/W (Kg)	Kühlmittelzufuhr Coolant supply	Bezeichnung Designation	Ident No.
12	58.0	32	42.0	41	M8X1.0	1.10	Form "AD/B"	WHEC-P/12-58/BT40	5159316
20	72.5	38	49.25	48	M8X1.0	1.40	Form "AD/B"	WHEC-P/20-72.5/BT40	5159317

BT50									
d (mm)	A	D1 (mm)	D2 (mm)	L	G	N/W (Kg)	Kühlmittelzufuhr Coolant supply	Bezeichnung Designation	Ident No.
20	83.5	38.0	49.25	48	M8X1.0	3.90	Form "AD/B"	WHEC-P/20-83.5/BT50	5159318
32	90.0	58.5	72.0	57	M8X1.0	4.60	Form "AD/B"	WHEC-P/32-90/BT50	5159319

≤ 3µm G2.5 25000 R.P.M. bar

≤ 3µm G2.5 25000 R.P.M. bar

≤ 3µm G2.5 25000 R.P.M. bar

Ersatzteile und Zubehör / Spare Parts & Accessories: Pg.D14

Pg.D20

# Hydrodehnspannfutter

## Hydraulic expansion chuck

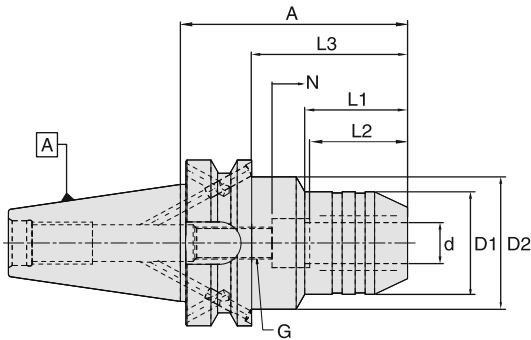

BT30												
d (mm)	A	D1 (mm)	D2 (mm)	L1	L2	L3	G	N	N/W (Kg)	Kühlmittelezufuhr Coolant supply	Bezeichnung Designation	Ident No.
06	70	26	44.5	29.5	27	48	M5X0.8	10	0.65	Form "AD"	WHEC/06-70/BT30	5066322
08	70	28	44.5	30.0	27	48	M6X1.0	10	0.65	Form "AD"	WHEC/08-70/BT30	5066324
10	75	30	44.5	31.0	32	53	M8X1.0	10	0.73	Form "AD"	WHEC/10-75/BT30	5066325
12	85	32	45.0	45.0	37	63	M10X1.0	10	0.80	Form "AD"	WHEC/12-85/BT30	5066326
14	85	34	45.0	45.0	37	63	M10X1.0	10	0.80	Form "AD"	WHEC/14-85/BT30	5066327
16	90	38	45.0	50.0	42	68	M12X1.0	10	0.90	Form "AD"	WHEC/16-90/BT30	5066328
20	90	42	45.0	50.0	42	68	M16X1.0	10	0.90	Form "AD"	WHEC/20-90/BT30	5066329

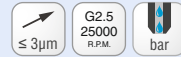

BT40												
d (mm)	A	D1 (mm)	D2 (mm)	L1	L2	L3	G	N	N/W (Kg)	Kühlmittelezufuhr Coolant supply	Bezeichnung Designation	Ident No.
06	90	26	44.5	43.0	27	63	M5X0.8	10	1.30	Form "AD/B"	WHEC/06-90/BT40	5062989
08	90	28	44.5	44.5	27	63	M6X1.0	10	1.30	Form "AD/B"	WHEC/08-90/BT40	5062991
10	90	30	44.5	44.5	32	63	M8X1.0	10	1.35	Form "AD/B"	WHEC/10-90/BT40	5062992
12	90	32	44.5	44.5	37	63	M10X1.0	10	1.35	Form "AD/B"	WHEC/12-90/BT40	5062994
14	90	34	44.5	44.5	37	63	M10X1.0	10	1.35	Form "AD/B"	WHEC/14-90/BT40	5062995
16	90	38	44.5	47.5	42	63	M12X1.0	10	1.40	Form "AD/B"	WHEC/16-90/BT40	5062996
18	90	40	44.5	47.5	42	63	M12X1.0	10	1.45	Form "AD/B"	WHEC/18-90/BT40	5062997
20	90	42	44.5	47.5	42	63	M16X1.0	10	1.50	Form "AD/B"	WHEC/20-90/BT40	5062998
25	100	50	60.0	47.5	48	73	M16X1.0	10	1.70	Form "AD/B"	WHEC/25-100/BT40	5062999
32	105	60			55	78	M16X1.0	10	2.10	Form "AD/B"	WHEC/32-105/BT40	5063000

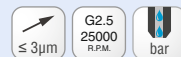

BT50												
d (mm)	A	D1 (mm)	D2 (mm)	L1	L2	L3	G	N	N/W (Kg)	Kühlmittelezufuhr Coolant supply	Bezeichnung Designation	Ident No.
06	90	26	44.5	34.0	27	52	M5X0.8	10	3.75	Form "AD/B"	WHEC/06-90/BT50	5063003
08	90	28	44.5	34.0	27	52	M6X1.0	10	3.75	Form "AD/B"	WHEC/08-90/BT50	5063016
10	90	30	44.5	34.0	32	52	M8X1.0	10	3.90	Form "AD/B"	WHEC/10-90/BT50	5063017
12	90	32	44.5	34.0	37	52	M10X1.0	10	3.90	Form "AD/B"	WHEC/12-90/BT50	5063018
14	90	34	44.5	34.0	37	52	M10X1.0	10	3.90	Form "AD/B"	WHEC/14-90/BT50	5063019
16	90	38	44.5	34.0	42	52	M12X1.0	10	4.00	Form "AD/B"	WHEC/16-90/BT50	5063020
18	90	40	44.5	34.0	42	52	M12X1.0	10	4.00	Form "AD/B"	WHEC/18-90/BT50	5063022
20	90	42	44.5	34.0	42	52	M16X1.0	10	4.00	Form "AD/B"	WHEC/20-90/BT50	5063023
25	105	57	63.0	52.0	48	67	M16X1.0	10	4.40	Form "AD/B"	WHEC/25-105/BT50	5063024
32	115	64	75.0	62.0	55	77	M16X1.0	10	4.70	Form "AD/B"	WHEC/32-115/BT50	5063025



Ersatzteile und Zubehör / Spare Parts & Accessories: Pg.D14 Pg.D20

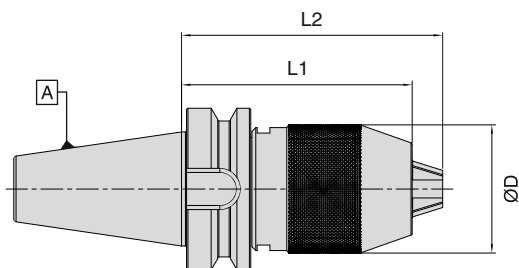

BT30							
D (mm)	L1 (mm)	L2 (mm)	Bereich Range	Kühlmittelezufuhr Coolant supply	N/W (Kg)	Bezeichnung Designation	Ident No.
50	116	128	1-13	-	1.51	WDC/1-13-116/BT30	66657334M

BT40							
D (mm)	A (mm)	L (mm)	Bereich Range	Kühlmittelezufuhr Coolant supply	N/W (Kg)	Bezeichnung Designation	Ident No.
50	92	104	1-13	-	1.77	WDC/1-13-92/BT40	66657335M

  

BT50							
D (mm)	A (mm)	L (mm)	Bereich Range	Kühlmittelezufuhr Coolant supply	N/W (Kg)	Bezeichnung Designation	Ident No.
50	103	115	1-13	-	4.33	WDC/1-13-103/BT50	66657336M



Original Albrecht design & licensed to Bilz

Zwischenhülsen für Morse-Kegel mit Anzugsgewinde DIN 6364 / 228A  
Adaptor sleeves for Morse taper with thread DIN 6364 / 228A

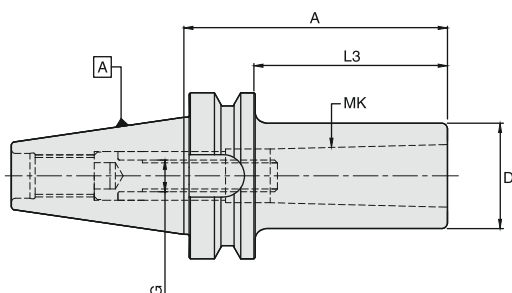

BT40								
MK	D (mm)	A (mm)	L3 (mm)	G	Kühlmittelezufuhr Coolant supply	N/W (Kg)	Bezeichnung Designation	Ident No.
1	25	50	23	M6	-	1.10	WMTB/MT1-50/BT40	5064368
2	32	50	32	M10	-	1.20	WMTB/MT2-50/BT40	5064369
3	40	70	40	M12	-	1.30	WMTB/MT3-70/BT40	5064370
4	48	95	48	M16	-	1.50	WMTB/MT4-95/BT40	5064371

BT50								
MK	D (mm)	A (mm)	L3 (mm)	G	Kühlmittelezufuhr Coolant supply	N/W (Kg)	Bezeichnung Designation	Ident No.
1	25	45	25	M6	-	3.80	WMTB/MT1-45/BT50	5064374
2	32	60	32	M10	-	3.90	WMTB/MT2-60/BT50	5064375
3	40	65	40	M12	-	3.90	WMTB/MT3-65/BT50	5064376
4	48	85	48	M16	-	4.00	WMTB/MT4-85/BT50	5064377
5	63	118	63	M20	-	4.20	WMTB/MT5-118/BT50	5064378



Ersatzteile und Zubehör / Spare Parts & Accessories:

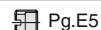

• Im Lieferumfang enthalten: eingebaute Innensechskantschraube

• Delivery includes: built-in draw screw

## Zwischenhülsen für Morse-Kegel mit Austreibblappen DIN 6383

Adaptor sleeves for Morse taper with tang to DIN 6383

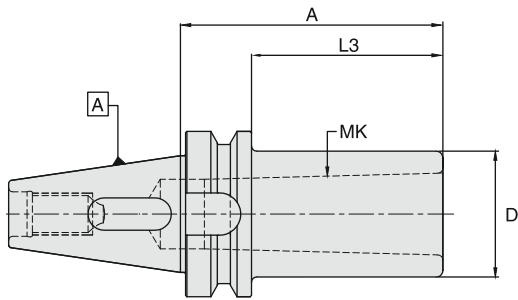

BT30							
MK	D (mm)	A (mm)	L3 (mm)	Kühlmittelzufuhr Coolant supply	N/W (Kg)	Bezeichnung Designation	Ident No.
1	25	45	23	-	1.1	WMTA/MT1-45/BT30	5066658
2	32	60	38	-	1.2	WMTA/MT2-60/BT30	5066659
3	40	75	53	-	1.3	WMTA/MT3-75/BT30	5066660

≤ 10µm  
 G2.5  
 18000 R.P.M.

BT40							
MK	D (mm)	A (mm)	L3 (mm)	Kühlmittelzufuhr Coolant supply	N/W (Kg)	Bezeichnung Designation	Ident No.
1	25	50	23	-	1.20	WMTA/MT1-50/BT40	5064401
2	32	50	23	-	1.20	WMTA/MT2-50/BT40	5064402
3	40	70	43	-	1.30	WMTA/MT3-70/BT40	5064403
4	48	95	68	-	1.50	WMTA/MT4-95/BT40	5064404

≤ 10µm  
 G2.5  
 18000 R.P.M.

BT50							
MK	D (mm)	A (mm)	L3 (mm)	Kühlmittelzufuhr Coolant supply	N/W (Kg)	Bezeichnung Designation	Ident No.
1	25	45	7	-	3.65	WMTA/MT1-45/BT50	5064405
2	32	60	22	-	3.70	WMTA/MT2-60/BT50	5064406
3	40	65	27	-	3.70	WMTA/MT3-65/BT50	5064407
4	48	95	57	-	3.90	WMTA/MT4-95/BT50	5064408
5	70	105	67	-	4.20	WMTA/MT5-105/BT50	5064410

≤ 10µm  
 G2.5  
 18000 R.P.M.

Ersatzteile und Zubehör / Spare Parts & Accessories: Pg.D20

Aufnahme für Einschraubfräser  
Chuck for threaded milling heads

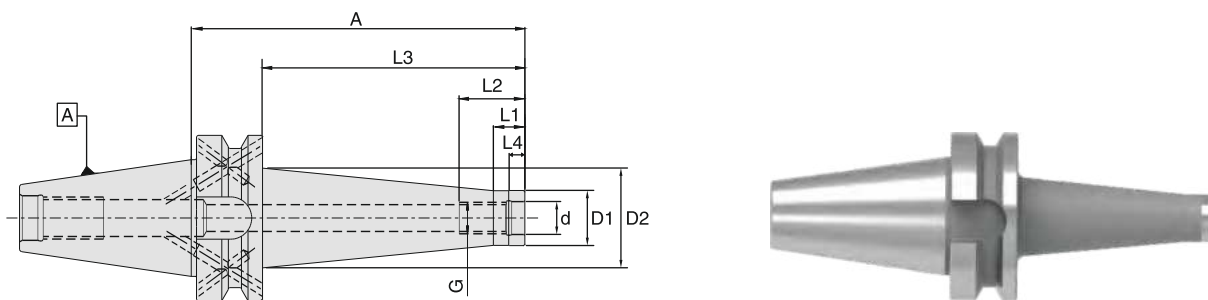

**BT40**

G	d (mm)	D1 (mm)	D2 (mm)	A (mm)	L1 (mm)	L2 (mm)	L3 (mm)	L4 (mm)	Kühlmittelzufuhr Coolant supply	N/W (Kg)	Bezeichnung Designation	Ident No.
M8	8.5	13.8	15	52	12	19	25	6.5	Form "AD/B"	1.0	WTA/M8-52/BT40	5065018
M8	8.5	13.8	23	77	12	19	50	6.5	Form "AD/B"	1.1	WTA/M8-77/BT40	5065019
M8	8.5	13.8	25	102	12	19	75	6.5	Form "AD/B"	1.3	WTA/M8-102/BT40	5065020
M10	10.5	18.0	23	52	12	19	25	6.5	Form "AD/B"	1.0	WTA/M10-52/BT40	5065021
M10	10.5	18.0	25	77	12	19	50	6.5	Form "AD/B"	1.2	WTA/M10-77/BT40	5065022
M10	10.5	18.0	30	102	12	19	75	6.5	Form "AD/B"	1.3	WTA/M10-102/BT40	5065023
M12	12.5	21.0	24	52	12	25	25	7.0	Form "AD/B"	1.0	WTA/M12-52/BT40	5065024
M12	12.5	21.0	30	77	12	25	50	7.0	Form "AD/B"	1.2	WTA/M12-77/BT40	5065025
M12	12.5	21.0	35	102	12	25	75	7.0	Form "AD/B"	1.3	WTA/M12-102/BT40	5065031
M12	12.5	21.0	38	127	12	25	100	7.0	Form "AD/B"	1.5	WTA/M12-127/BT40	5065032
M16	17.0	29.0	29	52	12	31	25	8.0	Form "AD/B"	1.1	WTA/M16-52/BT40	5065034
M16	17.0	29.0	34	77	12	31	50	8.0	Form "AD/B"	1.2	WTA/M16-77/BT40	5065035
M16	17.0	29.0	35	102	12	31	75	8.0	Form "AD/B"	1.4	WTA/M16-102/BT40	5065036
M16	17.0	29.0	40	127	12	31	100	8.0	Form "AD/B"	1.6	WTA/M16-127/BT40	5065038
M16	17.0	29.0	48	152	12	31	125	8.0	Form "AD/B"	2.0	WTA/M16-152/BT40	5065040
M16	17.0	29.0	52	177	12	31	150	8.0	Form "AD/B"	2.4	WTA/M16-177/BT40	5065041

**BT50**

G	d (mm)	D1 (mm)	D2 (mm)	A (mm)	L1 (mm)	L2 (mm)	L3 (mm)	L4 (mm)	Kühlmittelzufuhr Coolant supply	N/W (Kg)	Bezeichnung Designation	Ident No.
M12	12.5	21.0	35	88	12	25	50	7.0	Form "AD/B"	3.9	WTA/M12-88/BT50	5065046
M12	12.5	21.0	38	138	12	25	100	7.0	Form "AD/B"	4.0	WTA/M12-138/BT50	5065047
M12	12.5	21.0	48	188	12	25	150	7.0	Form "AD/B"	4.6	WTA/M12-188/BT50	5065048
M16	17.0	29.0	35	88	12	31	50	8.0	Form "AD/B"	3.9	WTA/M16-88/BT50	5065049
M16	17.0	29.0	40	113	12	31	75	8.0	Form "AD/B"	4.1	WTA/M16-113/BT50	5065050
M16	17.0	29.0	48	138	12	31	100	8.0	Form "AD/B"	4.4	WTA/M16-138/BT50	5065051
M16	17.0	29.0	52	188	12	31	150	8.0	Form "AD/B"	5.0	WTA/M16-188/BT50	5065052

Ersatzteile und Zubehör / Spare Parts & Accessories: Pg.D20

Siehe Seite D14 für Einschraubfräser Verlängerung & Reduzierung Refer page. D14 for Threaded Arbor extensions & reductions.

# Aufsteckfräserdorn DIN 6358 mit Längs- und Quernut (Kombination)

## Shell mill holder with DIN 6358 (Combination)

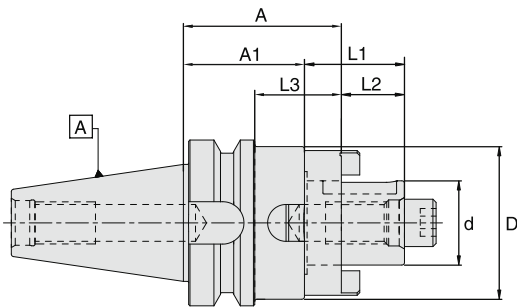

### BT30



d (mm)	D (mm)	A (mm)	A1 (mm)	L1 (mm)	L2 (mm)	L3 (mm)	Kühlmittelzufuhr Coolant supply	N/W (Kg)	Bezeichnung Designation	Ident No.
16	32	45	35	27	17	23	-	0.75	WFSH/16-45/BT30	6733419
22	40	47	35	31	19	25	-	0.85	WFSH/22-47/BT30	6733420
27	46	49	37	33	21	27	-	1.00	WFSH/27-49/BT30	6733421
16	32	80	70	27	17	58	-	1.00	WFSH/16-80/BT30	9202189
22	40	80	68	31	19	58	-	1.15	WFSH/22-80/BT30	9202190
27	48	90	78	33	21	68	-	1.60	WFSH/27-90/BT30	9202191

### BT40



d (mm)	D (mm)	A (mm)	A1 (mm)	L1 (mm)	L2 (mm)	L3 (mm)	Kühlmittelzufuhr Coolant supply	N/W (Kg)	Bezeichnung Designation	Ident No.
16	32	55	45	27	17	28	-	1.25	WFSH/16-55/BT40	6733423
22	40	55	43	31	19	28	-	1.40	WFSH/22-55/BT40	6733425
27	48	55	43	33	21	28	-	1.65	WFSH/27-55/BT40	6733427
32	58	60	46	38	24	33	-	2.00	WFSH/32-60/BT40	6733429
40	70	60	46	41	27	33	-	2.30	WFSH/40-60/BT40 **	4600948
16	32	100	90	27	17	73	-	1.60	WFSH/16-100/BT40	6733424
22	40	100	88	31	19	73	-	1.85	WFSH/22-100/BT40	6733426
27	48	100	88	33	21	73	-	2.30	WFSH/27-100/BT40	6733428
32	58	100	86	38	24	73	-	2.70	WFSH/32-100/BT40	6733430
40	70	100	86	41	27	73	-	3.50	WFSH/40-100/BT40 **	4600949

### BT50



d (mm)	D (mm)	A (mm)	A1 (mm)	L1 (mm)	L2 (mm)	L3 (mm)	Kühlmittelzufuhr Coolant supply	N/W (Kg)	Bezeichnung Designation	Ident No.
16	32	70	60	27	17	32	-	4.00	WFSH/16-70/BT50	4601448
22	40	70	58	31	19	32	-	4.20	WFSH/22-70/BT50	4601449
27	48	70	58	33	21	32	-	4.35	WFSH/27-70/BT50	4601450
32	58	70	56	38	24	32	-	4.70	WFSH/32-70/BT50	4601451
40	70	70	56	41	27	32	-	5.05	WFSH/40-70/BT50 **	4601452

Ersatzteile und Zubehör / Spare Parts & Accessories: Pg.E3 Pg.E4 Pg.E3 Pg.D21 Pg.D20

- Im Lieferumfang enthalten: Passfeder, Mitnehmerring, Innensechskantschraube (DIN 912)
- Spannschrauben (DIN 6367) bitte separat bestellen (Siehe Seite E3)
- \*\* Im Lieferumfang enthalten: Passfeder, Mitnehmerring, Fräseranzugsschraube (DIN 6367)

- Delivery includes: Parallel key, drive ring, socket head screw (DIN 912)
- Please order clamping screw DIN 6367 separately (refer page E3)
- \*\* Delivery includes: Parallel key, drive ring, clamping screw to DIN 6367



Aufnahmedorn mit Innenzentrierung DIN 6357 mit vergrößertem Bunddurchmesser  
Shell mill holder DIN 6357 for cutters with drive key

BT MAS 403  
ISO7388-2

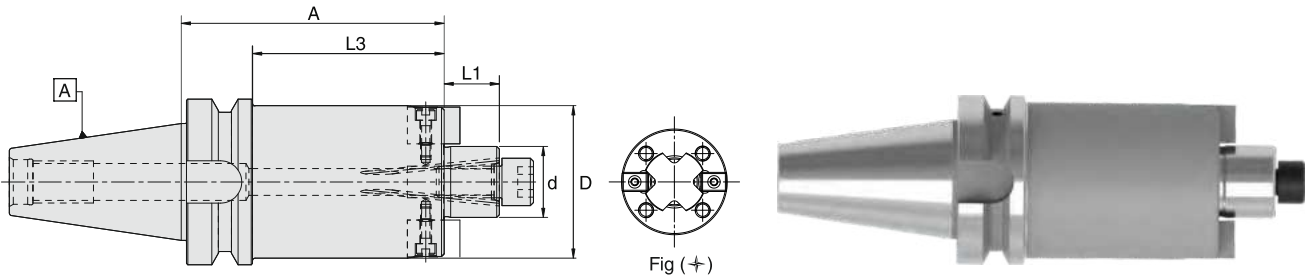

Fig (+)

BT30

d (mm)	D (mm)	A (mm)	L1 (mm)	L3 (mm)	Kühlmittelezufuhr Coolant supply	N/W (Kg)	Bezeichnung Designation	Ident No.
16	38	40	17	18	Form "AD"	0.70	WSMH/16-40/BT30	5067575
22	48	40	19	18	Form "AD"	0.85	WSMH/22-40/BT30	5067577
27	58	40	21	18	Form "AD"	1.00	WSMH/27-40/BT30	5067578
32	78	50	24	28	Form "AD"	1.00	WSMH/32-50/BT30	5067579

BT40

d (mm)	D (mm)	A (mm)	L1 (mm)	L3 (mm)	Kühlmittelezufuhr Coolant supply	N/W (Kg)	Bezeichnung Designation	Ident No.
16	38	40	17	13	Form "AD/B"	1.20	WSMH/16-40/BT40	5009952
22	48	40	19	13	Form "AD/B"	1.30	WSMH/22-40/BT40	5009953
27	58	40	21	13	Form "AD/B"	1.55	WSMH/27-40/BT40	5064794
32	78	50	24	23	Form "AD/B"	1.95	WSMH/32-50/BT40	5064795
40	88	50	27	23	Form "AD/B"	2.45	WSMH/40-50/BT40 †	5064798
16	38	100	17	73	Form "AD/B"	1.70	WSMH/16-100/BT40	5064801
22	48	100	19	73	Form "AD/B"	2.20	WSMH/22-100/BT40	5064802
27	58	100	21	73	Form "AD/B"	2.70	WSMH/27-100/BT40	5064803
32	78	100	24	73	Form "AD/B"	3.80	WSMH/32-100/BT40	5064804
40	88	100	27	73	Form "AD/B"	4.65	WSMH/40-100/BT40 †	5064805
16	38	160	17	133	Form "AD/B"	2.20	WSMH/16-160/BT40	5064806
22	48	160	19	133	Form "AD/B"	2.95	WSMH/22-160/BT40	5064810
27	58	160	21	133	Form "AD/B"	3.90	WSMH/27-160/BT40	5064827
32	78	160	24	133	Form "AD/B"	5.90	WSMH/32-160/BT40	5064829
40	88	160	27	133	Form "AD/B"	7.45	WSMH/40-160/BT40 †	5064830
22	48	200	19	173	Form "AD"	3.40	WSMH/22-200/BT40	66658681M
27	58	200	21	223	Form "AD"	4.55	WSMH/27-200/BT40	66658683M
22	48	250	19	173	Form "AD"	4.00	WSMH/22-250/BT40	66658682M
27	58	250	21	223	Form "AD"	5.56	WSMH/27-250/BT40	66658684M

Ersatzteile und Zubehör / Spare Parts & Accessories: Pg.D21 Pg.E3 Pg.E4 Pg.E4 Pg.D20

- Kühlbohrung an der Stirnseite Standard bei allen Grundhaltern
- † d = Ø 40, Ø 60 Mit 4 zusätzlichen Gewindebohrungen nach DIN 2079
- Im Lieferumfang enthalten: Mitnehmersteine und Innensechskantschraube (DIN 912)
- Spanschrauben (DIN 6367) bitte separat bestellen (Siehe Seite E3)
- Coolant bore on the pilot face (holder with Form "AD/B") as standard
- † d = Ø 40, Ø 60 with additional 4 screw holes to DIN 2079 and with locking screw (DIN 6367) for Ø40
- Delivery includes: Drive keys and socket head screw to DIN 912
- Please order clamping screw to DIN 6367 separately (refer page E3)

SK DIN 69871  
ISO7388-1

HSK DIN 69893

Zubehör  
Accessories

Ersatzteile  
Spare Parts

Technische Spezifikationen  
Technical Details

Aufnahmedorn mit Innenzentrierung DIN 6357 mit vergrößertem Bunddurchmesser  
Shell mill holder DIN 6357 for cutters with drive key

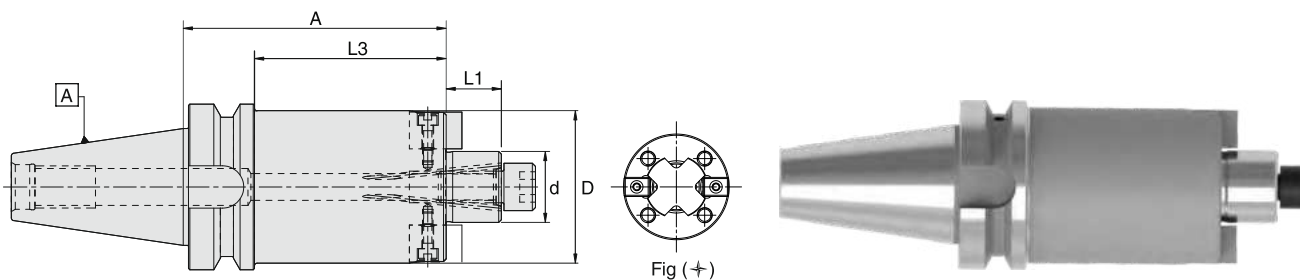

BT50



d (mm)	D (mm)	A (mm)	L1 (mm)	L3 (mm)	Kühlmittelezufuhr Coolant supply	N/W (Kg)	Bezeichnung Designation	Ident No.
16	38	63	17	25	Form "AD/B"	3.85	WSMH/16-63/BT50	5064832
22	48	63	19	25	Form "AD/B"	4.00	WSMH/22-63/BT50	5064834
27	58	63	21	25	Form "AD/B"	4.30	WSMH/27-63/BT50	5064835
32	78	60	24	22	Form "AD/B"	4.50	WSMH/32-60/BT50	5064836
40	88	60	27	22	Form "AD/B"	5.10	WSMH/40-60/BT50+	5064820
60	129	80	40	42	-	8.80	WSMH/60-80/BT50+	5064837
16	38	100	17	62	Form "AD/B"	4.25	WSMH/16-100/BT50	5064929
22	48	100	19	62	Form "AD/B"	4.60	WSMH/22-100/BT50	5064930
27	58	100	21	62	Form "AD/B"	5.10	WSMH/27-100/BT50	5064931
32	78	100	24	62	Form "AD/B"	6.30	WSMH/32-100/BT50	5064933
40	88	100	27	62	Form "AD/B"	6.80	WSMH/40-100/BT50+	5064934
16	38	160	17	122	Form "AD/B"	4.70	WSMH/16-160/BT50	5064936
22	48	160	19	122	Form "AD/B"	5.40	WSMH/22-160/BT50	5064937
27	58	160	21	122	Form "AD/B"	6.30	WSMH/27-160/BT50	5064938
32	78	160	24	122	Form "AD/B"	8.40	WSMH/32-160/BT50	5064940
40	88	160	27	122	Form "AD/B"	9.65	WSMH/40-160/BT50+	5064941
22	48	200	19	162	Form "AD"	5.81	WSMH/22-200/BT50 *	66658685M
27	58	200	21	162	Form "AD"	6.08	WSMH/27-200/BT50 *	66658687M
22	48	250	19	212	Form "AD"	6.49	WSMH/22-250/BT50 *	66658686M
27	58	250	21	212	Form "AD"	7.94	WSMH/27-250/BT50 *	66658688M
40	88	200	27	162	Form "AD"	11.30	WSMH/40-200/BT50 *	66658689M

Ersatzteile und Zubehör / Spare Parts & Accessories:



- Kühlbohrung an der Stirnseite Standard bei allen Grundhaltern
- + d = Ø 40, Ø 60 Mit 4 zusätzlichen Gewindebohrungen nach DIN 2079
- Im Lieferumfang enthalten: Mitnehmersteine und Innensechskantschraube (DIN 912)
- Spannschrauben (DIN 6367) bitte separat bestellen (Siehe Seite E3)
- \* Hinweis: Der Rundlauf variiert zwischen 10 und 15 Mikrometer über GPL 200 mm

- Coolant bore on the pilot face (holder with Form "AD/B") as standard
- + d = Ø 40, Ø 60 with additional 4 screw holes to DIN 2079 and with locking screw (DIN 6367) for Ø40
- Delivery includes: Drive keys and socket head screw to DIN 912
- Please order clamping screw to DIN 6367 separately (refer page E3)
- \* Note: Run-out will vary between 10-15 microns above GPL 200mm

## Zwischenhülsen Reduction Sleeves

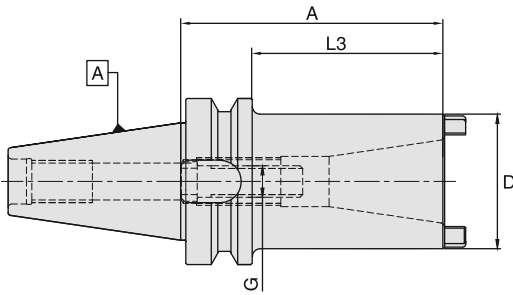

BT40								≤ 5µm	G2.5 18000 R.P.M.
Innenkegelgröße Inside Taper	D (mm)	A (mm)	L3 (mm)	G	Kühlmittelzufuhr Coolant supply	N/W (Kg)	Bezeichnung Designation	Ident No.	
SK 30	51	60	33	M12	-	1.65	BT40-SK30-60	4600865	
SK 40	63	100	-	M16	-	2.50	BT40-SK40-100	4600866	

BT50								≤ 5µm	G2.5 18000 R.P.M.
Innenkegelgröße Inside Taper	D (mm)	A (mm)	L3 (mm)	G	Kühlmittelzufuhr Coolant supply	N/W (Kg)	Bezeichnung Designation	Ident No.	
SK 40	63	70	32	M16	-	4.00	BT50-SK40-70	4601387	
SK 50	97	120	82	M24	-	7.60	BT50-SK50-120	4601388	

Ersatzteile und Zubehör / Spare Parts & Accessories: Pg.E7 Pg.D20 Pg.E7

- Im Lieferumfang enthalten: eingebaute Innensechskantschraube
- Delivery includes: built-in draw screw

## Bohrstangenrohlinge Boring bar blanks

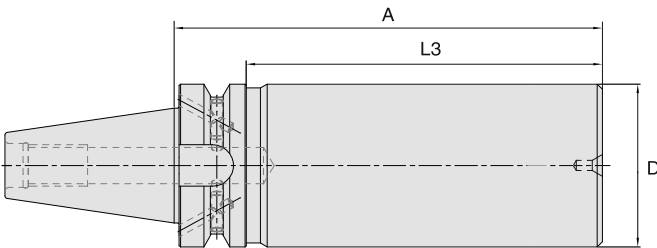

BT40							35 ± 5 HRC
D (mm)	A (mm)	L3 (mm)	Kühlmittelzufuhr Coolant supply	N/W (Kg)	Bezeichnung Designation	Ident No.	
63	250	223	Form "AD/B"	6.45	WBBB/63-250/BT40	5064955	

BT50							35 ± 5 HRC
D (mm)	A (mm)	L3 (mm)	Kühlmittelzufuhr Coolant supply	N/W (Kg)	Bezeichnung Designation	Ident No.	
63.5	300	262	Form "AD/B"	10.30	WBBB/63.5-300/BT50	5064956	

Ersatzteile und Zubehör / Spare Parts & Accessories: Pg.D20

- Im Lieferumfang enthalten: Steilkegel und Bund gehärtet und geschliffen, Schaft weich zur weiteren Bearbeitung
- Delivery includes: Steep taper and flange hardened, body left soft

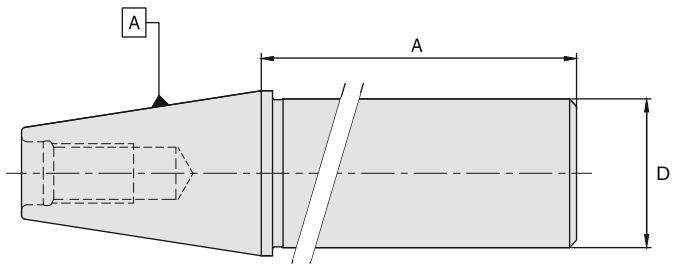
Kontrolldorn  
 Test Arbor

**BT40** ↗  
≤ 2µm

D (mm)	A (mm)	Kühlmittelzufuhr Coolant supply	N/W (Kg)	Bezeichnung Designation	Ident No.
40	330	-	4.10	WTMM/40-330/BT40	5083039

**BT50** ↗  
≤ 2µm

D (mm)	A (mm)	Kühlmittelzufuhr Coolant supply	N/W (Kg)	Bezeichnung Designation	Ident No.
50	330	-	7.60	WTMM/50-330/BT50	5056227

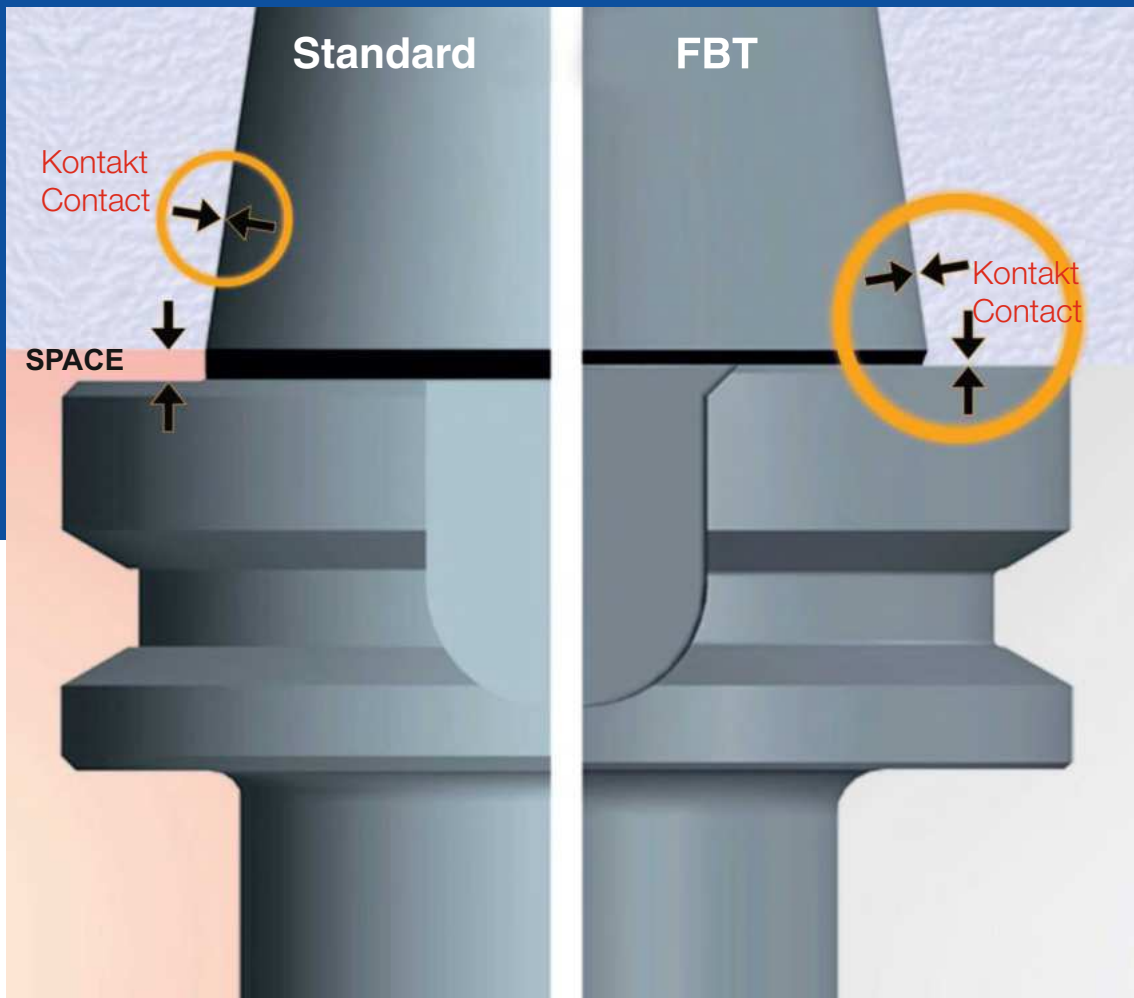
- |  |   |
|--|---|
| <ul style="list-style-type: none"> <li>• Diese Dorne haben keinen Bund</li> <li>• Kontrolldorne im Holzkasten geliefert</li> </ul> | <ul style="list-style-type: none"> <li>• These gauge are without flange</li> <li>• Delivered in wooden box</li> </ul> |
|--|---|



- Großflächiger und konischer Kontakt für optimierte Festigkeit und Steifigkeit
- Erhöhte Steifigkeit durch vergrößerte Anlagefläche
- Kein Axialspiel bei hohen Bearbeitungskräften
- Verbesserte Rundlaufeigenschaften
- Optimiertes Oberflächenfinish und höhere Maßhaltigkeit
- Large face and taper contact for optimized strength and rigidity
- Extremely high rigidity
- Maximum stability even at higher speeds
- Precise run-out
- Improved surface finish quality and accuracy compared to conventional BT spindle tapers

Spannzangenfutter ER Collet chuck ER	A27 - A28
Super collet Spannzangenfutter Super collet chuck	A29
Fräseraufnahmen (Weldon / Whistle Notch) End mill holder (Weldon / Whistle Notch)	A30 - A31
Hochleistungsfräaserspannfutter Hi-power milling chuck	A32 - A33
Micro-Spannzangenhalter Micro collet holder	A34
Hydrodehnspannfutter Hydraulic expansion chuck	A35
Aufnahmen für Morse-Kegel Morse taper holder	A36
Aufnahmen für Einschraubfräser Chuck for threaded milling heads	A37
Kombi-Aufsteckfräserdorn Combi shell mill holder	A38
Aufsteckfräserdorn Shell mill holder	A39
Kontrolldorn Test Arbor	A40

FBT - Spannzangenfutter Typ ER für Spannzangen ISO 15488 (DIN 6499)

FBT - Collet chuck Type ER for collets to ISO 15488 (DIN 6499)

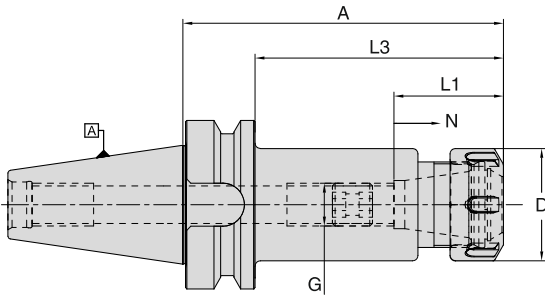

FBT30											
Spannzange Collet Type	Bereich Range	D (mm)	A (mm)	L1 (mm)	L3 (mm)	G (mm)	N	Kühlmittelzufuhr Coolant supply	N/W (Kg)	Bezeichnung Designation	Ident No.
ER 16	1-10	28	70	32.5	48	M10	12	Form "AD"	0.6	WCCH/ER16-70/FBT30	5126734
ER 20	1-13	34	70	38.0	48	M12	12	Form "AD"	0.7	WCCH/ER20-70/FBT30	5126736
ER 25	2-16	42	70	41.0	48	M12	12	Form "AD"	0.7	WCCH/ER25-70/FBT30	5126737
ER 32	2-20	50	70	47.0	48	M12	12	Form "AD"	0.8	WCCH/ER32-70/FBT30	5126738
ER 40	3-26	63	70	58.5	40	M12	12	Form "AD"	0.8	WCCH/ER40-70/FBT30	66658853M
ER 16	1-10	28	100	32.5	78	M10	12	Form "AD"	0.7	WCCH/ER16-100/FBT30	5126739
ER 20	1-13	34	100	38.0	78	M12	12	Form "AD"	0.9	WCCH/ER20-100/FBT30	5126740
ER 25	2-16	42	100	41.0	78	M12	12	Form "AD"	0.9	WCCH/ER25-100/FBT30	5126741
ER 32	2-20	50	100	47.0	78	M12	12	Form "AD"	0.9	WCCH/ER32-100/FBT30	66656181M

FBT40											
Spannzange Collet Type	Bereich Range	D (mm)	A (mm)	L1 (mm)	L3 (mm)	G (mm)	N	Kühlmittelzufuhr Coolant supply	N/W (Kg)	Bezeichnung Designation	Ident No.
ER 16	1-10	28	70	32.5	43	M10	12	Form "AD"	1.2	WCCH/ER16-70/FBT40	5126742
ER 20	1-13	34	70	38.0	43	M12	12	Form "AD"	1.2	WCCH/ER20-70/FBT40	5126743
ER 25	2-16	42	70	41.0	43	M16	12	Form "AD"	1.3	WCCH/ER25-70/FBT40	5126744
ER 32	2-20	50	70	47.0	43	M22X1.5	12	Form "AD"	1.4	WCCH/ER32-70/FBT40	5126745
ER 40	3-26	63	80	58.5	53	M22X1.5	12	Form "AD"	1.5	WCCH/ER40-80/FBT40	5126746
ER 16	1-10	28	100	32.5	73	M10	12	Form "AD"	1.3	WCCH/ER16-100/FBT40	5126747
ER 20	1-13	34	100	38.0	73	M12	12	Form "AD"	1.4	WCCH/ER20-100/FBT40	5126748
ER 25	2-16	42	100	41.0	73	M16	12	Form "AD"	1.4	WCCH/ER25-100/FBT40	5126749
ER 32	2-20	50	100	47.0	73	M22X1.5	12	Form "AD"	1.7	WCCH/ER32-100/FBT40	5126750
ER 40	3-26	63	100	58.5	73	M22X1.5	12	Form "AD"	1.9	WCCH/ER40-100/FBT40	5126756
ER 16	1-10	28	160	32.5	133	M10	12	Form "AD"	1.5	WCCH/ER16-160/FBT40❖	5126757
ER 20	1-13	34	160	38.0	133	M12	12	Form "AD"	1.8	WCCH/ER20-160/FBT40	5126758
ER 25	2-16	42	160	41.0	133	M16	12	Form "AD"	2.0	WCCH/ER25-160/FBT40	5126762
ER 32	2-20	50	160	47.0	133	M22X1.5	12	Form "AD"	2.5	WCCH/ER32-160/FBT40	5126876
ER 40	3-26	63	160	58.5	133	M22X1.5	12	Form "AD"	2.6	WCCH/ER40-160/FBT40	5126878

Ersatzteile und Zubehör / Spare Parts & Accessories: Pg.D20 Pg.D2-D4 Pg.D5 Pg.D7

- Im Lieferumfang enthalten: mit Spannmutter (gewuchtet) und Verstelle schraube
- Höhere Wuchtgüte auf Anfrage
- ❖ Für WCCH/ER16-160/FBT40, D2=43.2mm & L4=55.5mm

- Delivery includes: Clamping nut (balanced) & adjusting screw
- Higher balancing grade on request
- ❖ Note: For WCCH/ER16-160/FBT40, D2=43.2mm & L4=55.5mm

FBT - Spannzangenfutter Typ ER für Spannzangen ISO 15488 (DIN 6499)  
 FBT - Collet chuck Type ER for collets to ISO 15488 (DIN 6499)

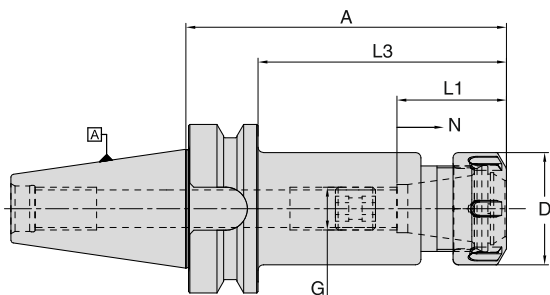

FBT50											
Spannzange Collet Type	Bereich Range	D (mm)	A (mm)	L1 (mm)	L3 (mm)	G (mm)	N	Kühlmittelzufuhr Coolant supply	N/W (Kg)	Bezeichnung Designation	Ident No.
ER 16	1-10	28	70	32.5	32	M10	12	Form "AD"	3.7	WCCH/ER16-70/FBT50	66658854M
ER 20	1-13	34	70	38.0	32	M12	12	Form "AD"	3.8	WCCH/ER20-70/FBT50	5126880
ER 25	2-16	42	70	41.0	32	M16	12	Form "AD"	3.7	WCCH/ER25-70/FBT50	5126881
ER 32	2-20	50	70	47.0	32	M22X1.5	12	Form "AD"	3.8	WCCH/ER32-70/FBT50	5126882
ER 40	3-26	63	80	58.5	42	M22X1.5	12	Form "AD"	4.0	WCCH/ER40-80/FBT50	5126883
ER 16	1-10	28	100	32.5	62	M10	12	Form "AD"	3.8	WCCH/ER16-100/FBT50	5126884
ER 20	1-13	34	100	38.0	62	M12	12	Form "AD"	3.9	WCCH/ER20-100/FBT50	5126886
ER 25	2-16	42	100	41.0	62	M16	12	Form "AD"	3.9	WCCH/ER25-100/FBT50	5126887
ER 32	2-20	50	100	47.0	62	M22X1.5	12	Form "AD"	4.1	WCCH/ER32-100/FBT50	5126889
ER 40	3-26	63	100	58.5	62	M22X1.5	12	Form "AD"	4.2	WCCH/ER40-100/FBT50	5126891
ER 16	1-10	28	160	32.5	122	M10	12	Form "AD"	4.1	WCCH/ER16-160/FBT50	5126892
ER 20	1-13	34	160	38.0	122	M12	12	Form "AD"	4.5	WCCH/ER20-160/FBT50	5126893
ER 25	2-16	42	160	41.0	122	M16	12	Form "AD"	4.6	WCCH/ER25-160/FBT50	5126894
ER 32	2-20	50	160	47.0	122	M22X1.5	12	Form "AD"	4.9	WCCH/ER32-160/FBT50	5126895
ER 40	3-26	63	160	58.5	122	M22X1.5	12	Form "AD"	5.0	WCCH/ER40-160/FBT50	5126896

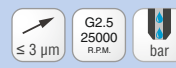

Ersatzteile und Zubehör / Spare Parts & Accessories:			
Pg.D20	Pg.D2-D4	Pg.D5	Pg.D7
<ul style="list-style-type: none"> <li>Im Lieferumfang enthalten: mit Spannmutter (gewuchtet) und Verstelle schraube</li> <li>Höhere Wuchtgüte auf Anfrage</li> </ul>		<ul style="list-style-type: none"> <li>Delivery includes: Clamping nut (balanced) &amp; adjusting screw</li> <li>Higher balancing grade on request</li> </ul>	



Super collet Spannzangenfutter  
Super collet chuck

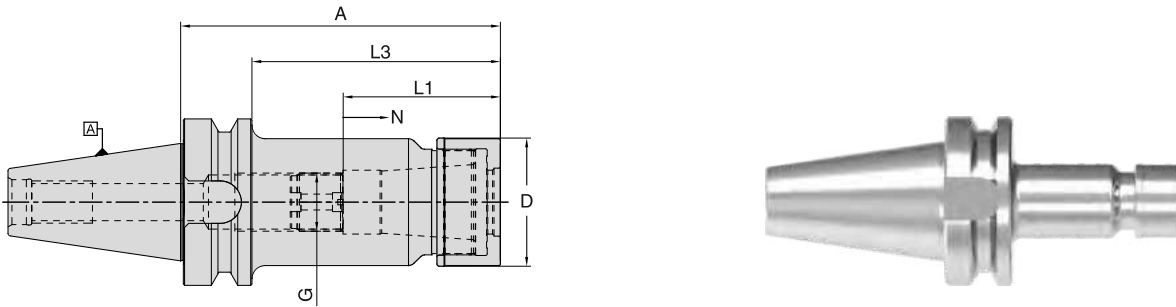

FBT30										≤ 2µm	G2.5 25000 RPM	bar
Spannzange Collet Type	Bereich Range	D (mm)	A (mm)	L1 (mm)	L3 (mm)	G (mm)	N (mm)	Kühlmittelzufuhr Coolant supply	N/W (Kg)	Bezeichnung Designation	Ident No.	
SC06	2-6	19.5	60	31.5	38	M8 x1	12	Form "AD"	0,53	WSCH/SCF06-60/FBT30	5127036	
SC10	2-10	27.1	60	35.0	38	M12 x1	12	Form "AD"	0,60	WSCH/SCF10-60/FBT30	5127039	
SC13	3-13	33.0	60	43.0	38	M15 x1	16	Form "AD"	0,62	WSCH/SCF13-60/FBT30	5127041	
SC16	3-16	40.0	60	52.0	38	M18 x1.5	16	Form "AD"	0,65	WSCH/SCF16-60/FBT30	5127052	
SC20	6-20	48.0	60	59.5	38	M18 x1.5	16	Form "AD"	0,70	WSCH/SCF20-60/FBT30	5127053	
SC06	2-6	19.5	90	31.5	68	M8 x1	12	Form "AD"	0,48	WSCH/SCF06-90/FBT30	66652488M	
SC10	2-10	27.1	90	35.0	68	M12 x1	12	Form "AD"	0,57	WSCH/SCF10-90/FBT30	66652490M	
SC13	3-13	33.0	90	43.0	68	M15 x1	16	Form "AD"	0,63	WSCH/SCF13-90/FBT30	66653440M	
SC16	6-20	40.0	90	59.5	68	M18 x1.5	16	Form "AD"	0,73	WSCH/SCF16-90/FBT30	66652493M	
SC20	6-20	48.0	90	63.5	68	M18 x1.5	16	Form "AD"	1,00	WSCH/SCF20-90/FBT30	66652495M	

FBT40										≤ 2µm	G2.5 25000 RPM	bar
Spannzange Collet Type	Bereich Range	D (mm)	A (mm)	L1 (mm)	L3 (mm)	G (mm)	N (mm)	Kühlmittelzufuhr Coolant supply	N/W (Kg)	Bezeichnung Designation	Ident No.	
SC06	2-6	19.5	90	31.5	63	M8 x1	12	Form "AD"	1,10	WSCH/SCF06-90/FBT40	5127054	
SC06	2-6	19.5	120	31.5	93	M8 x1	12	Form "AD"	1,20	WSCH/SCF06-120/FBT40	5127061	
SC10	2-10	27.1	90	35.0	63	M12 x1	12	Form "AD"	1,20	WSCH/SCF10-90/FBT40	5127055	
SC10	2-10	27.1	120	35.0	93	M12 x1	12	Form "AD"	1,35	WSCH/SCF10-120/FBT40	5127065	
SC13	3-13	33.0	90	43.0	63	M15 x1	16	Form "AD"	1,40	WSCH/SCF13-90/FBT40	5127056	
SC13	3-13	33.0	120	43.0	93	M15 x1	16	Form "AD"	1,50	WSCH/SCF13-120/FBT40	5127067	
SC16	3-16	40.0	90	52.0	63	M18 x1.5	16	Form "AD"	1,50	WSCH/SCF16-90/FBT40	5127057	
SC16	3-16	40.0	120	52.0	93	M18 x1.5	16	Form "AD"	1,70	WSCH/SCF16-120/FBT40	5127073	
SC20	6-20	48.0	90	59.5	63	M22 x1.5	16	Form "AD"	1,41	WSCH/SCF20-90/FBT40	5127058	
SC20	6-20	48.0	120	59.5	93	M22 x1.5	16	Form "AD"	2,01	WSCH/SCF20-120/FBT40	5127074	
SC25	6-25	55.0	90	63.5	63	M28 x1.5	20	Form "AD"	1,55	WSCH/SCF25-90/FBT40	5127059	
SC25	6-25	55.0	120	63.5	93	M28 x1.5	20	Form "AD"	2,20	WSCH/SCF25-120/FBT40	5127075	

Ersatzteile und Zubehör / Spare Parts & Accessories: Pg.D8-D9 Pg.D10 Pg.D9 Pg.D20

• Im Lieferumfang enthalten: mit Spannmutter (gewuchtet) und Verstellechraube • Delivery includes: Clamping nut (friction type), Adjusting screw

Technische Details siehe Seite F6-F7 / For technical details please refer the instruction manual provided in the packing box or refer page F6-F7

Fräseraufnahmen (Weldon) - für Zylinderschäfte gemäß DIN 1835B  
 End mill holder (Weldon) - For cylindrical shanks according to DIN 1835B

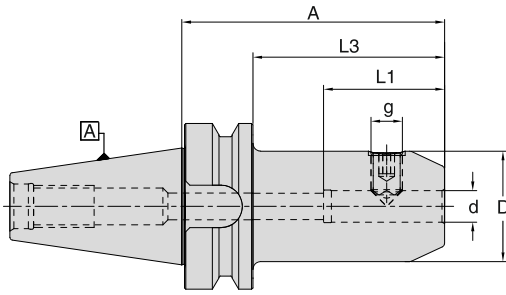

FBT30									
d (mm)	D (mm)	A (mm)	L1 (mm)	L3 (mm)	g	Kühlmittelzufuhr Coolant supply	N/W (Kg)	Bezeichnung Designation	Ident No.
06	25	50	37.0	28	M6	Form "AD"	0.50	WSLH/06-50/FBT30	5128896
08	28	50	37.0	28	M8	Form "AD"	0.50	WSLH/08-50/FBT30	5128899
10	35	50	41.0	28	M10	Form "AD"	0.60	WSLH/10-50/FBT30	5128901
12	42	50	46.0	28	M12	Form "AD"	0.65	WSLH/12-50/FBT30	5128902
14	44	50	46.0	28	M12	Form "AD"	0.65	WSLH/14-50/FBT30	5128903
16	48	63	49.0	41	M14	Form "AD"	0.90	WSLH/16-63/FBT30	5128904
18	50	63	49.0	41	M14	Form "AD"	0.95	WSLH/18-63/FBT30	5128905
20	52	63	51.0	41	M16	Form "AD"	0.95	WSLH/20-63/FBT30	5128906
25	65	90	59.0	61	M16	Form "AD"	1.05	WSLH/25-90/FBT30	66656290M

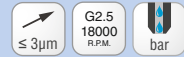

FBT40									
d (mm)	D (mm)	A (mm)	L1 (mm)	L3 (mm)	g	Kühlmittelzufuhr Coolant supply	N/W (Kg)	Bezeichnung Designation	Ident No.
16	48	35	49.0	8	M14	Form "AD"	1.05	WSLH/16-35/FBT40*	5128908
20	52	35	51.0	8	M16	Form "AD"	1.10	WSLH/20-35/FBT40*	5128909
25	45	35	59.0	8	M16	Form "AD"	1.00	WSLH/25-35/FBT40*	5128910
32	63	65	63.0	38	M20 x2	Form "AD"	1.50	WSLH/32-65/FBT40*	5128911
06	25	50	37.0	23	M6	Form "AD"	1.02	WSLH/06-50/FBT40	5128912
08	28	50	37.0	23	M8	Form "AD"	1.10	WSLH/08-50/FBT40	5128917
10	35	63	41.0	36	M10	Form "AD"	1.25	WSLH/10-63/FBT40	5128918
12	42	63	46.0	36	M12	Form "AD"	1.30	WSLH/12-63/FBT40	5128919
14	44	63	46.0	36	M12	Form "AD"	1.30	WSLH/14-63/FBT40	5128920
16	48	63	49.0	36	M14	Form "AD"	1.40	WSLH/16-63/FBT40	5128921
18	50	63	49.0	36	M14	Form "AD"	1.40	WSLH/18-63/FBT40	5128922
20	52	63	51.0	36	M16	Form "AD"	1.50	WSLH/20-63/FBT40	5128923
25	65	90	59.0	63	M18 x2	Form "AD"	2.20	WSLH/25-90/FBT40 **	5128924
32	72	100	63.0	73	M20 x2	Form "AD"	2.70	WSLH/32-100/FBT40 **	5128926
40	80	120	73.0	93	M20 x2	Form "AD"	3.55	WSLH/40-120/FBT40 **	5128927
06	25	100	37.0	73	M6	Form "AD"	1.22	WSLH/06-100/FBT40	5128929
08	28	100	37.0	73	M8	Form "AD"	1.30	WSLH/08-100/FBT40	5129001
10	35	100	41.0	73	M10	Form "AD"	1.50	WSLH/10-100/FBT40	5129002
12	42	100	46.0	73	M12	Form "AD"	1.70	WSLH/12-100/FBT40	5129003
14	44	100	46.0	73	M12	Form "AD"	1.70	WSLH/14-100/FBT40	5129004
16	48	100	49.0	73	M14	Form "AD"	1.85	WSLH/16-100/FBT40	5129006
18	50	100	49.0	73	M14	Form "AD"	1.90	WSLH/18-100/FBT40	5129007
20	52	100	51.0	73	M16	Form "AD"	2.00	WSLH/20-100/FBT40	5129008
06	25	160	37.0	133	M6	Form "AD"	1.60	WSLH/06-160/FBT40 ❖	5129832
08	28	160	37.0	133	M8	Form "AD"	1.75	WSLH/08-160/FBT40 ❖	5130641
10	35	160	41.0	133	M10	Form "AD"	2.05	WSLH/10-160/FBT40 ❖	5130642
12	42	160	46.0	133	M12	Form "AD"	2.30	WSLH/12-160/FBT40	5130643
14	44	160	46.0	133	M12	Form "AD"	2.40	WSLH/14-160/FBT40	5130644
16	48	160	49.0	133	M14	Form "AD"	2.70	WSLH/16-160/FBT40	5130645
18	50	160	49.0	133	M14	Form "AD"	2.80	WSLH/18-160/FBT40	5130646
20	52	160	51.0	133	M16	Form "AD"	2.90	WSLH/20-160/FBT40	5130647
25	65	160	59.0	133	M18 x2	Form "AD"	4.00	WSLH/25-160/FBT40 **	5130649
32	72	160	63.0	125	M20 x2	Form "AD"	4.53	WSLH/32-160/FBT40 **	66658868M

Fräseraufnahmen (Weldon) - für Zylinderschäfte gemäß DIN 1835B  
 End mill holder (Weldon) - For cylindrical shanks according to DIN 1835B

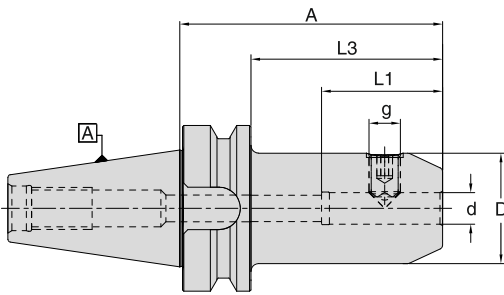

FBT50									
d (mm)	D (mm)	A (mm)	L1 (mm)	L3 (mm)	g	Kühlmittelzufuhr Coolant supply	N/W (Kg)	Bezeichnung Designation	Ident No.
06	25	63	37	25	M6	Form "AD"	3.70	WSLH/06-63/FBT50	5131410
08	28	63	37	25	M8	Form "AD"	3.70	WSLH/08-63/FBT50	5131411
10	35	63	41	25	M10	Form "AD"	3.80	WSLH/10-63/FBT50	5131412
12	42	80	46	42	M12	Form "AD"	4.00	WSLH/12-80/FBT50	5131413
14	44	80	46	42	M12	Form "AD"	4.00	WSLH/14-80/FBT50	5131415
16	48	80	49	42	M14	Form "AD"	4.05	WSLH/16-80/FBT50	5131416
18	50	80	49	42	M14	Form "AD"	4.10	WSLH/18-80/FBT50	5131417
20	52	80	51	42	M16	Form "AD"	4.15	WSLH/20-80/FBT50	5131768
25	65	100	59	62	M18 x2	Form "AD"	4.80	WSLH/25-100/FBT50 **	5131769
32	72	105	63	67	M20 x2	Form "AD"	5.15	WSLH/32-105/FBT50 **	5131770
40	80	110	73	72	M20 x2	Form "AD"	5.50	WSLH/40-110/FBT50 **	5131771
06	25	100	37	62	M6	Form "AD"	3.80	WSLH/06-100/FBT50	5131772
08	28	100	37	62	M8	Form "AD"	3.85	WSLH/08-100/FBT50	5131773
10	35	100	41	62	M10	Form "AD"	3.95	WSLH/10-100/FBT50	5131774
12	42	100	46	62	M12	Form "AD"	4.15	WSLH/12-100/FBT50	5131775
14	44	100	46	62	M12	Form "AD"	4.25	WSLH/14-100/FBT50	5131776
16	48	100	49	62	M14	Form "AD"	4.35	WSLH/16-100/FBT50	5131777
18	50	100	49	62	M14	Form "AD"	4.40	WSLH/18-100/FBT50	5131778
20	52	100	51	62	M16	Form "AD"	4.40	WSLH/20-100/FBT50	5131779
06	25	160	37	122	M6	Form "AD"	4.10	WSLH/06-160/FBT50 ❖	5131780
08	28	160	37	122	M8	Form "AD"	4.25	WSLH/08-160/FBT50 ❖	5131781
10	35	160	41	122	M10	Form "AD"	4.60	WSLH/10-160/FBT50 ❖	5131782
12	42	160	46	122	M12	Form "AD"	4.80	WSLH/12-160/FBT50	5131783
14	44	160	46	122	M12	Form "AD"	4.90	WSLH/14-160/FBT50	5131784
16	48	160	49	122	M14	Form "AD"	5.15	WSLH/16-160/FBT50	5131787
18	50	160	49	122	M14	Form "AD"	5.25	WSLH/18-160/FBT50	5131788
20	52	160	51	122	M16	Form "AD"	5.40	WSLH/20-160/FBT50	5131789
25	65	160	59	122	M18 x2	Form "AD"	6.25	WSLH/25-160/FBT50 **	5131790
32	72	160	63	122	M20 x2	Form "AD"	6.80	WSLH/32-160/FBT50 **	5131791



Ersatzteile und Zubehör / Spare Parts & Accessories: Pg.D20

Pg.E2

\*\* 2 Spannschrauben für ID Größe = 25 / 32 / 40

\* Extra kurze Aufnahmen: Die Spannschrauben sind im Mitnehmer, Maximale Steifigkeit dank kurzer Auskragslänge

- Bohrungstoleranz H4
- Im Lieferumfang enthalten: Spannschraube
- Höhere Wuchtgüte auf Anfrage

- ❖ Für WSLH/06-160/FBT40, D2=44.6mm & L4=50mm
- Für WSLH/08-160/FBT40, D2=47.6mm & L4=50mm
- Für WSLH/10-160/FBT40, D2=53.3mm & L4=60mm
- Für WSLH/06-160/FBT50, D2=39.5mm & L4=50mm
- Für WSLH/08-160/FBT50, D2=42.4mm & L4=50mm
- Für WSLH/10-160/FBT50, D2=49.4mm & L4=50mm

\*\* 2 locking screws for ID size = 25 / 32 / 40 | • Bore tolerance H4

\* Extra short holders: Locking screws are located in the same place as drive slots | Gives maximum rigidity due to short projection

- Delivery includes: Locking screw
- Higher balancing grade on request

- ❖ For WSLH/06-160/FBT40, D2=44.6mm & L4=50mm
- For WSLH/08-160/FBT40, D2=47.6mm & L4=50mm
- For WSLH/10-160/FBT40, D2=53.3mm & L4=60mm
- For WSLH/06-160/FBT50, D2=39.5mm & L4=50mm
- For WSLH/08-160/FBT50, D2=42.4mm & L4=50mm
- For WSLH/10-160/FBT50, D2=49.4mm & L4=50mm

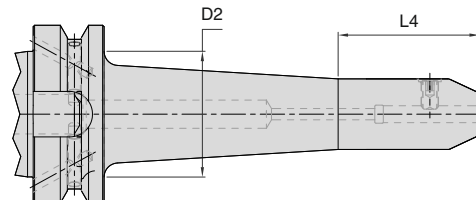

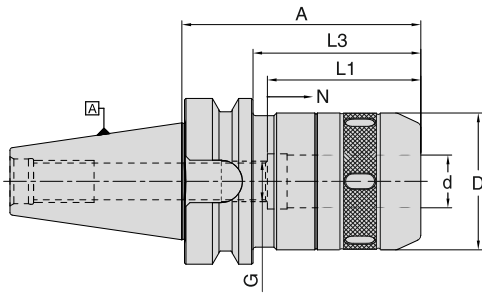

**FBT30**



d (mm)	D (mm)	A (mm)	L1 (mm)	L3 (mm)	G	N	Kühlmittelfuhr Coolant supply	N/W (Kg)	Bezeichnung Designation	Ident No.
20	52	90	60	68	M12x1	15	Form "AD"	1.45	WHPMC/20-90/FBT30	5131797
25	58	90	70	68	M12x1	15	Form "AD"	1.55	WHPMC/25-90/FBT30	5131819
32	66	105	75	83	M12x1	15	Form "AD"	1.85	WHPMC/32-105/FBT30	5131820

**FBT40**



d (mm)	D (mm)	A (mm)	L1 (mm)	L3 (mm)	G	N	Kühlmittelfuhr Coolant supply	N/W (Kg)	Bezeichnung Designation	Ident No.
20	52	90	60	63	M12x1	15	Form "AD"	2.35	WHPMC/20-90/FBT40	5131821
25	58	90	70	63	M16x1	15	Form "AD"	2.10	WHPMC/25-90/FBT40	5131822
32	66	105	75	78	M16x1	15	Form "AD"	2.60	WHPMC/32-105/FBT40	5131823

**FBT50**

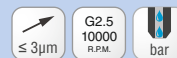

d (mm)	D (mm)	A (mm)	L1 (mm)	L3 (mm)	G	N	Kühlmittelfuhr Coolant supply	N/W (Kg)	Bezeichnung Designation	Ident No.
20	52	90	60	52	M12x1	15	Form "AD"	5.55	WHPMC/20-90/FBT50	5131824
25	58	90	60	52	M16x1	15	Form "AD"	4.55	WHPMC/25-90/FBT50	5131825
32	66	105	75	67	M16x1	15	Form "AD"	4.90	WHPMC/32-105/FBT50	5131826
20	52	160	60	122	M12x1	15	Form "AD"	6.83	WHPMC/20-160/FBT50	66658863M
25	58	160	60	122	M16x1	15	Form "AD"	5.70	WHPMC/25-160/FBT50	66658864M
32	66	160	75	122	M16x1	15	Form "AD"	6.28	WHPMC/32-160/FBT50	66658865M

Ersatzteile und Zubehör / Spare Parts & Accessories:

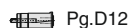

Technische Details siehe Seite F4-F5 / For technical details please refer the instruction manual provided in the packing box or refer page F4-F5

# Schlanke Hochleistungsfräserspannfutter

## Slim Hi-Power Milling Chuck

BT MAS 403  
ISO7388-2

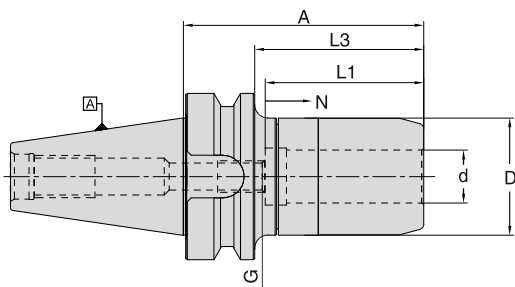

### FBT30



d (mm)	D (mm)	A (mm)	L1 (mm)	L3 (mm)	G	N	Kühlmittelezufuhr Coolant Supply	N/W (Kg)	Bezeichnung Designation	Ident No.
6	25	100	36	78	-	8	Form "AD"	0,90	WHPMC/S06-100/FBT30	5131827
8	25	100	36	78	-	8	Form "AD"	0,90	WHPMC/S08-100/FBT30	5131828
10	30	100	42	78	M8x1	8	Form "AD"	0,90	WHPMC/S10-100/FBT30	5131830
12	30	70	45	48	M8	8	Form "AD"	0,85	WHPMC/S12-70/FBT30	5131831
12	30	120	45	98	M8	8	Form "AD"	1,20	WHPMC/S12-120/FBT30	5131832
16	38	70	50	48	-	10	Form "AD"	0,80	WHPMC/S16-70/FBT30	5131833
16	38	120	50	98	-	10	Form "AD"	1,20	WHPMC/S16-120/FBT30	5131834

### FBT40



d (mm)	D (mm)	A (mm)	L1 (mm)	L3 (mm)	G	N	Kühlmittelezufuhr Coolant Supply	N/W (Kg)	Bezeichnung Designation	Ident No.
6	25	100	36	73	-	8	Form "AD"	1,70	WHPMC/S06-100/FBT40	5131875
8	25	100	36	73	-	8	Form "AD"	1,70	WHPMC/S08-100/FBT40	5131880
10	30	100	42	73	-	8	Form "AD"	1,70	WHPMC/S10-100/FBT40	5131883
12	30	70	45	43	-	8	Form "AD"	1,55	WHPMC/S12-70/FBT40	5131884
12	30	120	45	93	-	8	Form "AD"	1,85	WHPMC/S12-120/FBT40	5131885
16	38	70	50	43	-	10	Form "AD"	1,45	WHPMC/S16-70/FBT40	5131886
16	38	120	50	93	M8	10	Form "AD"	2,20	WHPMC/S16-120/FBT40	5131887
20	44	90	55	63	M12x1	10	Form "AD"	2,10	WHPMC/S20-90/FBT40	5131889
20	44	150	55	123	-	10	Form "AD"	2,90	WHPMC/S20-150/FBT40	5131890

### FBT50



d (mm)	D (mm)	A (mm)	L1 (mm)	L3 (mm)	G	N	Kühlmittelezufuhr Coolant Supply	N/W (Kg)	Bezeichnung Designation	Ident No.
12	30	90	45	52	-	8	Form "AD"	4,95	WHPMC/S12-90/FBT50	5131893
12	30	120	45	82	-	8	Form "AD"	5,15	WHPMC/S12-120/FBT50	5131894
16	38	90	50	52	-	10	Form "AD"	5,20	WHPMC/S16-90/FBT50	5131895
16	38	120	50	82	-	10	Form "AD"	5,35	WHPMC/S16-120/FBT50	5131896
20	44	100	55	62	-	10	Form "AD"	5,45	WHPMC/S20-100/FBT50	5131897
20	44	150	55	112	-	10	Form "AD"	6,00	WHPMC/S20-150/FBT50	5131898

Ersatzteile und Zubehör / Spare Parts & Accessories:

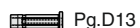

Technische Details siehe Seite F4-F5 / For technical details please refer the instruction manual provided in the packing box or refer page F4-F5

SK DIN 69871  
ISO7388-1

HSK DIN 69893

Zubehör  
Accessories

Ersatzteile  
Spare Parts

Technische Spezifikationen  
Technical Details

# Mini-Spannzangenhalter

## Mini collet holder

BT MAS 403  
ISO7388-2

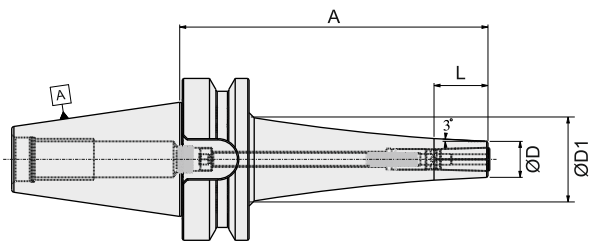

FBT30									
Spannzange Collet Type	Bereich Range	A (mm)	L (mm)	D (mm)	D1 (mm)	Kühlmittelzufuhr Coolant supply	N/W (Kg)	Bezeichnung Designation	Ident No.
MC14	3-6	90	21	14	29	-	0,55	WMCH/D14-90/FBT30	66658701M
MC14	3-6	120	21	14	33	-	0,67	WMCH/D14-120/FBT30	66658702M

SK DIN 69871  
ISO7388-1



FBT40									
Spannzange Collet Type	Bereich Range	A (mm)	L (mm)	D (mm)	D1 (mm)	Kühlmittelzufuhr Coolant supply	N/W (Kg)	Bezeichnung Designation	Ident No.
MC14	3-6	90	21.0	14	29.0	-	1,2	WMCH/D14-90/FBT40	66658272M
MC14	3-6	120	21.0	14	33.0	-	1,3	WMCH/D14-120/FBT40	66658273M
MC14	3-6	150	21.0	14	42.0	-	1,6	WMCH/D14-150/FBT40	66658705M
MC21	6-12	90	31.5	21	33.9	-	1,3	WMCH/D21-90/FBT40	66658722M
MC21	6-12	120	31.5	21	43.0	-	1,6	WMCH/D21-120/FBT40	66658723M
MC21	6-12	150	31.5	21	42.9	-	1,8	WMCH/D21-150/FBT40	66658724M

HSK DIN 69893



FBT50									
Spannzange Collet Type	Bereich Range	A (mm)	L1 (mm)	D (mm)	D1 (mm)	Kühlmittelzufuhr Coolant supply	N/W (Kg)	Bezeichnung Designation	Ident No.
MC14	3-6	90	21.0	14	25.6	-	3,8	WMCH/D14-90/FBT50	66658706M
MC14	3-6	120	21.0	14	35.0	-	3,9	WMCH/D14-120/FBT50	66658707M
MC14	3-6	150	21.0	14	42.0	-	4,1	WMCH/D14-150/FBT50	66658773M
MC21	6-12	90	31.5	21	30.5	-	3,9	WMCH/D21-90/FBT50	66658725M
MC21	6-12	120	31.5	21	40.0	-	4,1	WMCH/D21-120/FBT50	66658726M
MC21	6-12	150	31.5	21	50.0	-	4,4	WMCH/D21-150/FBT50	66658727M

Zubehör  
Accessories

Ersatzteile und Zubehör / Spare Parts & Accessories: Pg.D20 Pg.D16 Pg.D16 Pg.D16

Ersatzteile  
Spare Parts

Technische Spezifikationen  
Technical Details

# Hydrodehnspannfutter

## Hydraulic expansion chuck

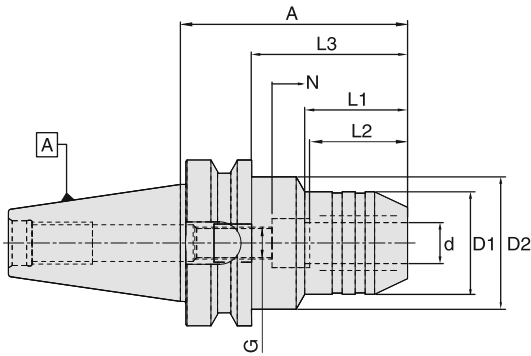

FBT30												
d (mm)	A	D1 (mm)	D2 (mm)	L1	L2	L3	G	N	N/W (Kg)	Kühlmittelzufuhr Coolant supply	Bezeichnung Designation	Ident No.
06	70	26	44.5	29.5	27	48	M5X0.8	10	0.65	Form "AD"	WHEC/06-70/FBT30	5131900
08	70	28	44.5	30.0	27	48	M6X1.0	10	0.65	Form "AD"	WHEC/08-70/FBT30	5131901
10	75	30	44.5	31.0	32	53	M8X1.0	10	0.73	Form "AD"	WHEC/10-75/FBT30	5131902
12	85	32	45.0	45.0	37	63	M10X1.0	10	0.80	Form "AD"	WHEC/12-85/FBT30	5131903
14	85	34	45.0	45.0	37	63	M10X1.0	10	0.80	Form "AD"	WHEC/14-85/FBT30	5131904
16	90	38	45.0	50.0	42	68	M12X1.0	10	0.90	Form "AD"	WHEC/16-90/FBT30	5131905
20	90	42	45.0	50.0	42	68	M16X1.0	10	0.90	Form "AD"	WHEC/20-90/FBT30	5131906

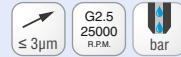

FBT40												
d (mm)	A	D1 (mm)	D2 (mm)	L1	L2	L3	G	N	N/W (Kg)	Kühlmittelzufuhr Coolant supply	Bezeichnung Designation	Ident No.
06	90	26	44.5	43.0	27	63	M5X0.8	10	1.30	Form "AD"	WHEC/06-90/FBT40	5131908
08	90	28	44.5	44.5	27	63	M6X1.0	10	1.30	Form "AD"	WHEC/08-90/FBT40	5131909
10	90	30	44.5	44.5	32	63	M8X1.0	10	1.35	Form "AD"	WHEC/10-90/FBT40	5132040
12	90	32	44.5	44.5	37	63	M10X1.0	10	1.35	Form "AD"	WHEC/12-90/FBT40	5132041
14	90	34	44.5	44.5	37	63	M10X1.0	10	1.35	Form "AD"	WHEC/14-90/FBT40	5132042
16	90	38	44.5	47.5	42	63	M12X1.0	10	1.40	Form "AD"	WHEC/16-90/FBT40	5132043
18	90	40	44.5	47.5	42	63	M12X1.0	10	1.45	Form "AD"	WHEC/18-90/FBT40	5132044
20	90	42	44.5	47.5	42	63	M16X1.0	10	1.50	Form "AD"	WHEC/20-90/FBT40	5132045
25	100	50	60.0	47.5	48	73	M16X1.0	10	1.70	Form "AD"	WHEC/25-100/FBT40	5132046
32	105	60			55	78	M16X1.0	10	2.10	Form "AD"	WHEC/32-105/FBT40	5132048

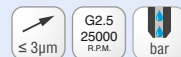

FBT50												
d (mm)	A	D1 (mm)	D2 (mm)	L1	L2	L3	G	N	N/W (Kg)	Kühlmittelzufuhr Coolant supply	Bezeichnung Designation	Ident No.
06	90	26	44.5	34.0	27	52	M5X0.8	10	3.75	Form "AD"	WHEC/06-90/FBT50	5132049
08	90	28	44.5	34.0	27	52	M6X1.0	10	3.75	Form "AD"	WHEC/08-90/FBT50	5132050
10	90	30	44.5	34.0	32	52	M8X1.0	10	3.90	Form "AD"	WHEC/10-90/FBT50	5132051
12	90	32	44.5	34.0	37	52	M10X1.0	10	3.90	Form "AD"	WHEC/12-90/FBT50	5132052
14	90	34	44.5	34.0	37	52	M10X1.0	10	3.90	Form "AD"	WHEC/14-90/FBT50	5132053
16	90	38	44.5	34.0	42	52	M12X1.0	10	4.00	Form "AD"	WHEC/16-90/FBT50	5132054
18	90	40	44.5	34.0	42	52	M12X1.0	10	4.00	Form "AD"	WHEC/18-90/FBT50	5132055
20	90	42	44.5	34.0	42	52	M16X1.0	10	4.00	Form "AD"	WHEC/20-90/FBT50	5132056
25	105	57	63.0	52.0	48	67	M16X1.0	10	4.40	Form "AD"	WHEC/25-105/FBT50	5132057
32	115	64	75.0	62.0	55	77	M16X1.0	10	4.70	Form "AD"	WHEC/32-115/FBT50	5132058



Ersatzteile und Zubehör / Spare Parts & Accessories: Pg.D14 Pg.D20

## Zwischenhülsen für Morse-Kegel mit Austreibblappen DIN 6383

Adaptor sleeves for Morse taper with tang to DIN 6383

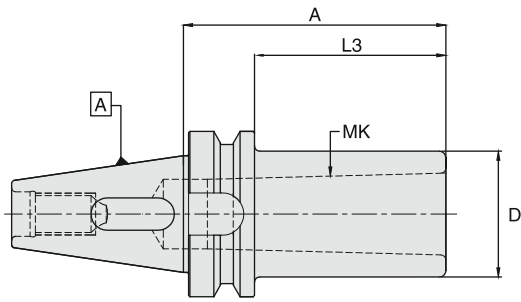

FBT30							
MK	D (mm)	A (mm)	L3 (mm)	Kühlmittelzufuhr Coolant supply	N/W (Kg)	Bezeichnung Designation	Ident No.
1	25	45	23	-	1.1	WMTA/MT1-45/FBT30	5132139
2	32	60	38	-	1.2	WMTA/MT2-60/FBT30	5132140
3	40	75	53	-	1.3	WMTA/MT3-75/FBT30	5132142

≤ 10µm G2.5  
18000 RPM

FBT40							
MK	D (mm)	A (mm)	L3 (mm)	Kühlmittelzufuhr Coolant supply	N/W (Kg)	Bezeichnung Designation	Ident No.
1	25	50	23	-	1.20	WMTA/MT1-50/FBT40	5132143
2	32	50	23	-	1.20	WMTA/MT2-50/FBT40	5132144
3	40	70	43	-	1.30	WMTA/MT3-70/FBT40	5132145
4	48	95	68	-	1.50	WMTA/MT4-95/FBT40	5132146

≤ 10µm G2.5  
18000 RPM

FBT50							
MK	D (mm)	A (mm)	L3 (mm)	Kühlmittelzufuhr Coolant supply	N/W (Kg)	Bezeichnung Designation	Ident No.
1	25	45	7	-	3.65	WMTA/MT1-45/FBT50	5132229
2	32	60	22	-	3.70	WMTA/MT2-60/FBT50	5132230
3	40	65	27	-	3.70	WMTA/MT3-65/FBT50	5132231
4	48	95	57	-	3.90	WMTA/MT4-95/FBT50	5132233
5	70	105	67	-	4.20	WMTA/MT5-105/FBT50	5132237

≤ 10µm G2.5  
18000 RPM

Ersatzteile und Zubehör / Spare Parts & Accessories: Pg.D20



Aufnahme für Einschraubfräser  
Chuck for threaded milling heads

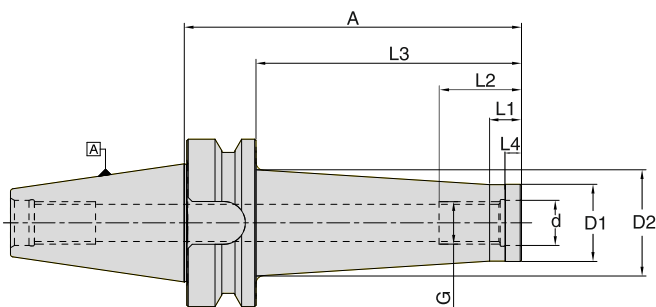

FBT40

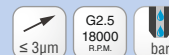

G	d (mm)	D1 (mm)	D2 (mm)	A (mm)	L1 (mm)	L2 (mm)	L3 (mm)	L4 (mm)	Kühlmittelzufuhr Coolant supply	N/W (Kg)	Bezeichnung Designation	Ident No.
M8	8.5	13.8	23	77	12	19	50	6.5	Form "AD"	1.1	WTA/M8-77/FBT40	5132238
M8	8.5	13.8	25	102	12	19	75	6.5	Form "AD"	1.3	WTA/M8-102/FBT40	5132239
M10	10.5	18.0	25	77	12	19	50	6.5	Form "AD"	1.2	WTA/M10-77/FBT40	5132240
M10	10.5	18.0	30	102	12	19	75	6.5	Form "AD"	1.3	WTA/M10-102/FBT40	5132241
M12	12.5	21.0	30	77	12	25	50	7.0	Form "AD"	1.2	WTA/M12-77/FBT40	5132242
M12	12.5	21.0	35	102	12	25	75	7.0	Form "AD"	1.3	WTA/M12-102/FBT40	5132243
M12	12.5	21.0	38	127	12	25	100	7.0	Form "AD"	1.5	WTA/M12-127/FBT40	5132244
M16	17.0	29.0	34	77	12	31	50	8.0	Form "AD"	1.2	WTA/M16-77/FBT40	5132245
M16	17.0	29.0	35	102	12	31	75	8.0	Form "AD"	1.4	WTA/M16-102/FBT40	5132246
M16	17.0	29.0	40	127	12	31	100	8.0	Form "AD"	1.6	WTA/M16-127/FBT40	5132247

FBT50



G	d (mm)	D1 (mm)	D2 (mm)	A (mm)	L1 (mm)	L2 (mm)	L3 (mm)	L4 (mm)	Kühlmittelzufuhr Coolant supply	N/W (Kg)	Bezeichnung Designation	Ident No.
M12	12.5	21.0	35	88	12	25	50	7.0	Form "AD"	3.9	WTA/M12-88/FBT50	5132248
M16	17.0	29.0	35	88	12	31	50	8.0	Form "AD"	3.9	WTA/M16-88/FBT50	5132249

Ersatzteile und Zubehör / Spare Parts & Accessories: Pg.D20

Siehe Seite D14 für Einschraubfräser Verlängerung & Reduzierung

Refer page. D14 for Threaded Arbor extensions & reductions.

Aufsteckfräserdorn DIN 6358 mit Längs- und Quernut (Kombination)  
Shell mill holder with DIN 6358 (Combination)

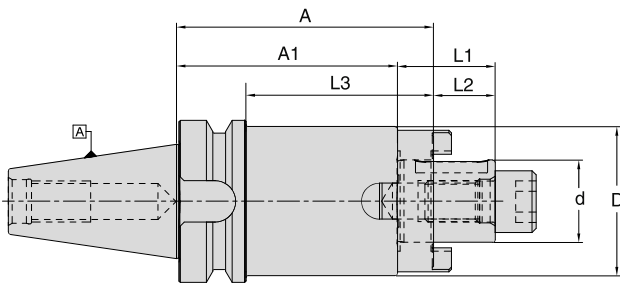

FBT30										
d (mm)	D (mm)	A (mm)	A1 (mm)	L1 (mm)	L2 (mm)	L3 (mm)	Kühlmittelezufuhr Coolant supply	N/W (Kg)	Bezeichnung Designation	Ident No.
16	32	45	35	27	17	23	-	0.75	WFSH/16-45/FBT30	5132301
22	40	47	35	31	19	25	-	0.85	WFSH/22-47/FBT30	5132302
27	46	49	37	33	21	27	-	1.00	WFSH/27-49/FBT30	5132303

≤ 5µm G2.5  
18000  
R.P.M.

FBT40										
d (mm)	D (mm)	A (mm)	A1 (mm)	L1 (mm)	L2 (mm)	L3 (mm)	Kühlmittelezufuhr Coolant supply	N/W (Kg)	Bezeichnung Designation	Ident No.
16	32	55	45	27	17	28	-	1.25	WFSH/16-55/FBT40	5132304
22	40	55	43	31	19	28	-	1.40	WFSH/22-55/FBT40	5132305
27	48	55	43	33	21	28	-	1.65	WFSH/27-55/FBT40	5132306
32	58	60	46	38	24	33	-	2.00	WFSH/32-60/FBT40	5132307
40	70	60	46	41	27	33	-	2.30	WFSH/40-60/FBT40 **	5132308
16	32	100	90	27	17	73	-	1.60	WFSH/16-100/FBT40	5132309
22	40	100	88	31	19	73	-	1.85	WFSH/22-100/FBT40	5132312
27	48	100	88	33	21	73	-	2.30	WFSH/27-100/FBT40	5132313
32	58	100	86	38	24	73	-	2.70	WFSH/32-100/FBT40	5132314
40	70	100	86	41	27	73	-	3.50	WFSH/40-100/FBT40 **	5132315

≤ 5µm G2.5  
18000  
R.P.M.

FBT50										
d (mm)	D (mm)	A (mm)	A1 (mm)	L1 (mm)	L2 (mm)	L3 (mm)	Kühlmittelezufuhr Coolant supply	N/W (Kg)	Bezeichnung Designation	Ident No.
16	32	70	60	27	17	32	-	4.00	WFSH/16-70/FBT50	5132399
22	40	70	58	31	19	32	-	4.20	WFSH/22-70/FBT50	5132401
27	48	70	58	33	21	32	-	4.35	WFSH/27-70/FBT50	5132402
32	58	70	56	38	24	32	-	4.70	WFSH/32-70/FBT50	5132403
40	70	70	56	41	27	32	-	5.05	WFSH/40-70/FBT50 **	5132404

≤ 5µm G2.5  
18000  
R.P.M.

Ersatzteile und Zubehör / Spare Parts & Accessories: Pg.E3 Pg.E4 Pg.E3 Pg.D21 Pg.D20

- Im Lieferumfang enthalten: Passfeder, Mitnehmerring, Fräseranzugsschraube und Spannschrauben (DIN 912)
- Spannschrauben (DIN 6367) bitte separat bestellen (Siehe Seite E3)
- \*\* Im Lieferumfang enthalten: Spannschrauben (DIN 6367)

- Delivery includes: Parallel key, drive ring, socket head screw (DIN 912)
- Please order clamping screw DIN 6367 separately (refer page E3)
- \*\* Delivery includes: Parallel key, drive ring, clamping screw to DIN 6367

Aufnahmedorn mit Innenzentrierung DIN 6357 mit vergrößertem Bunddurchmesser  
Shell mill holder DIN 6357 for cutters with drive key

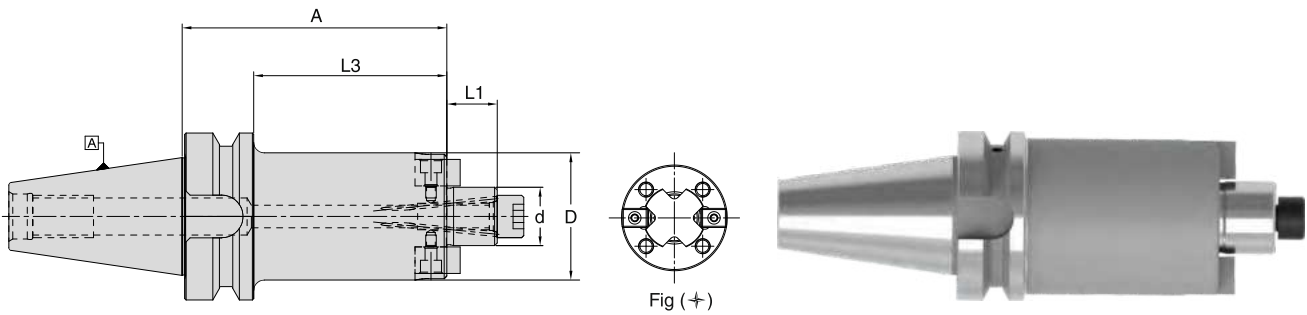

FBT30						
-------	--	--	--	--	--	--

d (mm)	D (mm)	A (mm)	L1 (mm)	L3 (mm)	Kühlmittelezufuhr Coolant supply	N/W (Kg)	Bezeichnung Designation	Ident No.
16	38	40	17	18	Form "AD"	0.70	WSMH/16-40/FBT30	5132405
22	48	40	19	18	Form "AD"	0.85	WSMH/22-40/FBT30	5132406
27	58	40	21	18	Form "AD"	1.00	WSMH/27-40/FBT30	5132407
32	78	50	24	28	Form "AD"	1.00	WSMH/32-50/FBT30	5132408

FBT40				
-------	--	--	--	--

d (mm)	D (mm)	A (mm)	L1 (mm)	L3 (mm)	Kühlmittelezufuhr Coolant supply	N/W (Kg)	Bezeichnung Designation	Ident No.
16	38	40	17	13	Form "AD"	1.20	WSMH/16-40/FBT40	5132414
22	48	40	19	13	Form "AD"	1.30	WSMH/22-40/FBT40	5132415
27	58	40	21	13	Form "AD"	1.55	WSMH/27-40/FBT40	5132416
32	78	50	24	23	Form "AD"	1.95	WSMH/32-50/FBT40	5132418
40	88	50	27	23	Form "AD"	2.45	WSMH/40-50/FBT40+	5132427
16	38	100	17	73	Form "AD"	1.70	WSMH/16-100/FBT40	5132431
22	48	100	19	73	Form "AD"	2.20	WSMH/22-100/FBT40	5132433
27	58	100	21	73	Form "AD"	2.70	WSMH/27-100/FBT40	5132544
32	78	100	24	73	Form "AD"	3.80	WSMH/32-100/FBT40	5132546
40	88	100	27	73	Form "AD"	4.65	WSMH/40-100/FBT40+	5132547
16	38	160	17	133	Form "AD"	2.20	WSMH/16-160/FBT40	5132548
22	48	160	19	133	Form "AD"	2.95	WSMH/22-160/FBT40	5132549
27	58	160	21	133	Form "AD"	3.90	WSMH/27-160/FBT40	5132550
32	78	160	24	133	Form "AD"	5.90	WSMH/32-160/FBT40	5132551
40	88	160	27	133	Form "AD"	7.45	WSMH/40-160/FBT40+	5132553

FBT50				
-------	--	--	--	--

d (mm)	D (mm)	A (mm)	L1 (mm)	L3 (mm)	Kühlmittelezufuhr Coolant supply	N/W (Kg)	Bezeichnung Designation	Ident No.
16	38	63	17	25	Form "AD"	3.85	WSMH/16-63/FBT50	5132554
22	48	63	19	25	Form "AD"	4.00	WSMH/22-63/FBT50	5132555
27	58	63	21	25	Form "AD"	4.30	WSMH/27-63/FBT50	5132556
32	78	60	24	22	Form "AD"	4.50	WSMH/32-60/FBT50	5132557
40	88	60	27	22	Form "AD"	5.10	WSMH/40-60/FBT50+	5132558
60	129	80	40	42	-	8.80	WSMH/60-80/FBT50+	5132559
16	38	100	17	62	Form "AD"	4.25	WSMH/16-100/FBT50	5126640
22	48	100	19	62	Form "AD"	4.60	WSMH/22-100/FBT50	5126641
27	58	100	21	62	Form "AD"	5.10	WSMH/27-100/FBT50	5126643
32	78	100	24	62	Form "AD"	6.30	WSMH/32-100/FBT50	5126644
40	88	100	27	62	Form "AD"	6.80	WSMH/40-100/FBT50+	5126645
16	38	160	17	122	Form "AD"	4.70	WSMH/16-160/FBT50	5126646
22	48	160	19	122	Form "AD"	5.40	WSMH/22-160/FBT50	5126647
27	58	160	21	122	Form "AD"	6.30	WSMH/27-160/FBT50	5126648
32	78	160	24	122	Form "AD"	8.40	WSMH/32-160/FBT50	5126649
40	88	160	27	122	Form "AD"	9.65	WSMH/40-160/FBT50+	5126650

Ersatzteile und Zubehör / Spare Parts & Accessories: Pg.D21 Pg.E3 Pg.E4 Pg.E4 Pg.D20

- |   |  |
|---|--|
| <p>+ d = Ø 40, Ø 60 Mit 4 zusätzlichen Gewindebohrungen nach DIN 2079</p> <ul style="list-style-type: none"> <li>• Im Lieferumfang enthalten: Mitnehmersteine und Innensechskantschraube (DIN 912)</li> <li>• Spannschrauben (DIN 6367) bitte separat bestellen (Siehe Seite E3)</li> </ul> | <p>+ d = Ø 40, Ø 60 with additional 4 screw holes to DIN 2079 and with locking screw (DIN 6367) for Ø40</p> <ul style="list-style-type: none"> <li>• Delivery includes: Drive keys and socket head screw to DIN 912</li> <li>• Please order locking screw (DIN 6367) separately (refer page E3)</li> </ul> |
|---|--|

Kontrolldorn  
Test Arbor

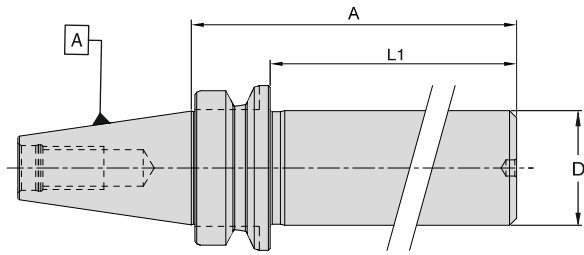

FBT30 <span style="float: right;">↗ ≤ 2µm</span>						
D (mm)	A (mm)	L1 (mm)	Kühlmittelzufuhr Coolant supply	N/W (Kg)	Bezeichnung Designation	Ident No.
32	230	208	-	1.68	WTMM/32-230/FBT30	5126651

FBT40 <span style="float: right;">↗ ≤ 2µm</span>						
D (mm)	A (mm)	L1 (mm)	Kühlmittelzufuhr Coolant supply	N/W (Kg)	Bezeichnung Designation	Ident No.
40	330	303	-	4.10	WTMM/40-330/FBT40	5126652

FBT50 <span style="float: right;">↗ ≤ 2µm</span>						
D (mm)	A (mm)	L1 (mm)	Kühlmittelzufuhr Coolant supply	N/W (Kg)	Bezeichnung Designation	Ident No.
50	330	292	-	7.60	WTMM/50-330/FBT50	5126654

<ul style="list-style-type: none"> <li>• Diese Dorne haben keinen Bund</li> <li>• Kontrolldorne im Holzkasten geliefert</li> </ul>	<ul style="list-style-type: none"> <li>• These gauge are without flange</li> <li>• Delivered in wooden box</li> </ul>
--	---

Spannzangenfutter ER Collet chuck ER	B2 - B3
Super collet Spannzangenfutter Super collet chuck	B4
Fräseraufnahmen (Weldon & Whistle Notch) End mill holder (Weldon & Whistle Notch)	B5 - B8
Hochleistungsfräterspannfutter Hi-power milling chuck	B9
Mini-Spannzangenhalter Mini collet holder	B9
Präzisions-Bohrfutter Precision drill chuck	B10
Aufnahmen für Morse-Kegel Morse taper holder (with thread & tang)	B10 - B11
Aufnahmen für Einschraubfräser Chuck for threaded milling heads	B12
Kombi-Aufsteckfräserdorne Combi shell mill holder	B13
Messerkopf-Aufnahme Shell mill holder	B14
Reduzierhülsen Reduction Sleeves	B15
Bohrstangenrohlinge Boring bar blanks	B15
Kontrolldorn Test Arbor	B16

Spannzangenfutter Typ ER für Spannzangen DIN 6499  
Collet chuck Type ER for collets to DIN 6499

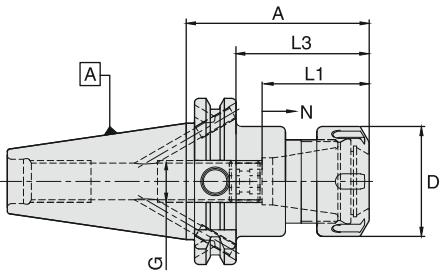

SK30											
Spannzange Collet Type	Bereich Range	D (mm)	A (mm)	L1 (mm)	L3 (mm)	G	N	Kühlmittelezufuhr Coolant supply	N/W (Kg)	Bezeichnung Designation	Ident No.
ER16	1-10	28	70	32.5	50.9	M10	12	Form "AD"	0.60	WCCH/ER16-70/SK30	6733310
ER25	2-16	42	70	41.0	50.9	M12	12	Form "AD"	0.75	WCCH/ER25-70/SK30	4600545
ER32	2-20	50	70	47.0	50.9	M12	12	Form "AD"	0.75	WCCH/ER32-70/SK30	4600547
ER16	1-10	28	100	32.5	80.9	M10	12	Form "AD"	0.70	WCCH/ER16-100/SK30	6733311
ER25	2-16	42	100	41.0	80.9	M12	12	Form "AD"	1.10	WCCH/ER25-100/SK30	4600546
ER32	2-20	50	100	47.0	80.9	M12	12	Form "AD"	1.10	WCCH/ER32-100/SK30	4600548



SK40											
Spannzange Collet Type	Bereich Range	D (mm)	A (mm)	L1 (mm)	L3 (mm)	G	N	Kühlmittelezufuhr Coolant supply	N/W (Kg)	Bezeichnung Designation	Ident No.
ER16	1-10	28	70	32.5	50.9	M10	12	Form "AD/B"	1.00	WCCH/ER16-70/SK40	6733316
ER20	1-13	34	70	38.0	50.9	M12	12	Form "AD/B"	1.10	WCCH/ER20-70/SK40	6733319
ER25	2-16	42	70	41.0	50.9	M16	12	Form "AD/B"	1.30	WCCH/ER25-70/SK40	6733322
ER32	2-20	50	70	47.0	50.9	M22X1.5	12	Form "AD/B"	1.30	WCCH/ER32-70/SK40	6733325
ER40	3-26	63	80	58.5	60.9	M22X1.5	12	Form "AD/B"	1.45	WCCH/ER40-80/SK40	6733328
ER16	1-10	28	100	32.5	80.9	M10	12	Form "AD/B"	1.45	WCCH/ER16-100/SK40	6733317
ER20	1-13	34	100	38.0	80.9	M12	12	Form "AD/B"	1.30	WCCH/ER20-100/SK40	6733320
ER25	2-16	42	100	41.0	80.9	M16	12	Form "AD/B"	1.45	WCCH/ER25-100/SK40	6733323
ER32	2-20	50	100	47.0	80.9	M22X1.5	12	Form "AD/B"	1.65	WCCH/ER32-100/SK40	6733326
ER40	3-26	63	100	58.5	80.9	M22X1.5	12	Form "AD/B"	1.80	WCCH/ER40-100/SK40	6733329
ER16	1-10	28	160	32.5	140.9	M10	12	Form "AD/B"	1.50	WCCH/ER16-160/SK40	4600735
ER20	1-13	34	160	38.0	140.9	M12	12	Form "AD/B"	1.70	WCCH/ER20-160/SK40	5055182
ER25	2-16	42	160	41.0	140.9	M16	12	Form "AD/B"	2.00	WCCH/ER25-160/SK40	4600738
ER32	2-20	50	160	47.0	140.9	M22X1.5	12	Form "AD/B"	2.40	WCCH/ER32-160/SK40	4600741
ER40	3-26	63	160	58.5	140.9	M22X1.5	12	Form "AD/B"	2.55	WCCH/ER40-160/SK40	4600744



Ersatzteile und Zubehör / Spare Parts & Accessories: Pg.D19 Pg.D2-D4 Pg.D5 Pg.D7

- Datenträger-Bohrung (10 mm) Standard bei allen Grundhaltern
- Im Lieferumfang enthalten: Spannmutter (gewuchtet) und Einstellschraube
- Höhere Wuchtgüte auf Anfrage
- Innere Kühlmittelzufuhr auf Anfrage
- Data carrier bore (10 mm) as standard for all holders
- Delivery includes: Clamping nut (balanced) & adjusting screw
- Higher balancing grade on request
- Coolant nut based IRC on request

# Spannzangenfutter Typ ER für Spannzangen DIN 6499

## Collet chuck Type ER for collets to DIN 6499

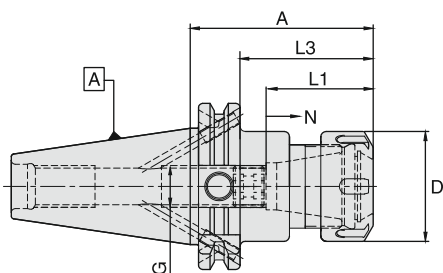

SK50

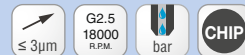

Spannzange Collet Type	Bereich Range	D (mm)	A (mm)	L1 (mm)	L3 (mm)	G	N	Kühlmittelzufuhr Coolant supply	N/W (Kg)	Bezeichnung Designation	Ident No.
ER16	1-10	28	63	32.5	43.9	M10	12	Form "AD/B"	2.80	WCCH/ER16-63/SK50	5055191
ER20	1-13	34	70	38	50.9	M12	12	Form "AD/B"	2.90	WCCH/ER20-70/SK50	5055192
ER25	2-16	42	70	41	50.9	M16	12	Form "AD/B"	2.95	WCCH/ER25-70/SK50	4601279
ER32	2-20	50	70	47	50.9	M22X1.5	12	Form "AD/B"	2.95	WCCH/ER32-70/SK50	4601282
ER40	3-26	63	80	58.5	60.9	M22X1.5	12	Form "AD/B"	3.20	WCCH/ER40-80/SK50	4601285
ER16	1-10	28	100	32.5	80.9	M10	12	Form "AD/B"	2.95	WCCH/ER16-100/SK50	4601277
ER20	1-13	34	100	38	80.9	M12	12	Form "AD/B"	3.10	WCCH/ER20-100/SK50	5055194
ER25	2-16	42	100	41	80.9	M16	12	Form "AD/B"	3.20	WCCH/ER25-100/SK50	4601280
ER32	2-20	50	100	47	80.9	M22X1.5	12	Form "AD/B"	3.40	WCCH/ER32-100/SK50	4601283
ER40	3-26	63	100	58.5	80.9	M22X1.5	12	Form "AD/B"	3.50	WCCH/ER40-100/SK50	4601286
ER16	1-10	28	160	32.5	140.9	M10	12	Form "AD/B"	4.10	WCCH/ER16-160/SK50	4601278
ER20	1-13	34	160	38	140.9	M12	12	Form "AD/B"	3.75	WCCH/ER20-160/SK50	5055195
ER25	2-16	42	160	41	140.9	M16	12	Form "AD/B"	3.85	WCCH/ER25-160/SK50	4601281
ER32	2-20	50	160	47	140.9	M22X1.5	12	Form "AD/B"	4.20	WCCH/ER32-160/SK50	4601284
ER40	3-26	63	160	58.5	140.9	M22X1.5	12	Form "AD/B"	4.30	WCCH/ER40-160/SK50	4601287

Ersatzteile und Zubehör / Spare Parts & Accessories:



- Datenträger-Bohrung (10mm) Standard bei allen Grundhaltern
- Im Lieferumfang enthalten: Spannmutter (gewuchtet) und Einstellschraube
- Höhere Wuchtgüte auf Anfrage
- Innere Kühlmittelzufuhr auf Anfrage

- Data carrier bore (10 mm) as standard for all holders
- Delivery includes: Clamping nut (balanced) & adjusting screw
- Higher balancing grade on request
- Coolant nut based IRC on request

Super collet Spannzangenfutter  
Super collet chuck

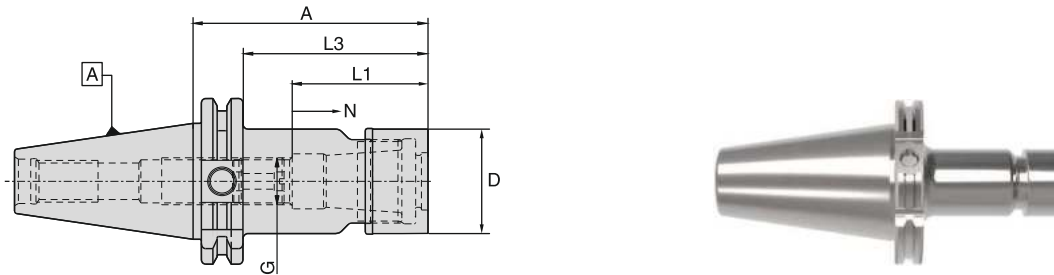

SK40											
Spannzange Collet Type	Bereich Range	D (mm)	A (mm)	L1 (mm)	L3 (mm)	G (mm)	N (mm)	Kühlmittelezufuhr Coolant supply	N/W (Kg)	Bezeichnung Designation	Ident No.
SC06	2-6	19.5	90	31.5	70.9	M8 x1	12	Form "AD"	1,05	WSCH/SCF06-90/SK40	5102046
SC06	2-6	19.5	120	31.5	100.9	M8 x1	12	Form "AD"	1,10	WSCH/SCF06-120/SK40	5102048
SC06	2-6	19.5	150	31.5	130.9	M8 x1	12	Form "AD"	1,25	WSCH/SCF06-150/SK40	5102050
SC10	2-10	27.1	90	35.0	70.9	M12 x1	12	Form "AD"	1,15	WSCH/SCF10-90/SK40	5102051
SC10	2-10	27.1	120	35.0	100.9	M12 x1	12	Form "AD"	1,35	WSCH/SCF10-120/SK40	5102053
SC10	2-10	27.1	150	35.0	130.9	M12 x1	12	Form "AD"	1,40	WSCH/SCF10-150/SK40	5102057
SC13	3-13	33.0	90	43.0	70.9	M15 x1	16	Form "AD"	1,20	WSCH/SCF13-90/SK40	5102059
SC13	3-13	33.0	120	43.0	100.9	M15 x1	16	Form "AD"	1,45	WSCH/SCF13-120/SK40	5102060
SC13	3-13	33.0	150	43.0	130.9	M15 x1	16	Form "AD"	1,60	WSCH/SCF13-150/SK40	5102061
SC16	3-16	40.0	90	52.0	70.9	M18 x1.5	16	Form "AD"	1,40	WSCH/SCF16-90/SK40	5102062
SC16	3-16	40.0	120	52.0	100.9	M18 x1.5	16	Form "AD"	1,60	WSCH/SCF16-120/SK40	5102063
SC16	3-16	40.0	150	52.0	130.9	M18 x1.5	16	Form "AD"	1,90	WSCH/SCF16-150/SK40	5102068
SC20	6-20	48.0	90	59.5	70.9	M22 x1.5	16	Form "AD"	1,60	WSCH/SCF20-90/SK40	5102070
SC20	6-20	48.0	120	59.5	100.9	M22 x1.5	16	Form "AD"	2,00	WSCH/SCF20-120/SK40	5102071
SC20	6-20	48.0	150	59.5	130.9	M22 x1.5	16	Form "AD"	2,35	WSCH/SCF20-150/SK40	5102072
SC25	6-25	55.0	90	63.5	70.9	M28 x1.5	20	Form "AD"	1,40	WSCH/SCF25-90/SK40	5102073
SC25	6-25	55.0	120	63.5	100.9	M28 x1.5	20	Form "AD"	1,80	WSCH/SCF25-120/SK40	5102074
SC25	6-25	55.0	150	63.5	130.9	M28 x1.5	20	Form "AD"	2,10	WSCH/SCF25-150/SK40	5102075



SK50											
Spannzange Collet Type	Bereich Range	D (mm)	A (mm)	L1 (mm)	L3 (mm)	G (mm)	N (mm)	Kühlmittelezufuhr Coolant supply	N/W (Kg)	Bezeichnung Designation	Ident No.
SC06	2-6	19.5	105	31.5	70.9	M8 x1	12	Form "AD"	2,90	WSCH/SCF06-105/SK50	5102076
SC06	2-6	19.5	135	31.5	100.9	M8 x1	12	Form "AD"	2,95	WSCH/SCF06-135/SK50	5102077
SC06	2-6	19.5	165	31.5	130.9	M8 x1	12	Form "AD"	3,00	WSCH/SCF06-165/SK50	5102078
SC10	2-10	27.1	105	35.0	70.9	M12 x1	12	Form "AD"	3,05	WSCH/SCF10-105/SK50	5102079
SC10	2-10	27.1	135	35.0	100.9	M12 x1	12	Form "AD"	3,15	WSCH/SCF10-135/SK50	5102080
SC10	2-10	27.1	165	35.0	130.9	M12 x1	12	Form "AD"	3,35	WSCH/SCF10-165/SK50	5102081
SC13	3-13	33.0	105	43.0	70.9	M15 x1	16	Form "AD"	3,20	WSCH/SCF13-105/SK50	5102082
SC13	3-13	33.0	135	43.0	100.9	M15 x1	16	Form "AD"	3,30	WSCH/SCF13-135/SK50	5102083
SC13	3-13	33.0	165	43.0	130.9	M15 x1	16	Form "AD"	3,50	WSCH/SCF13-165/SK50	5102084
SC16	3-16	40.0	105	52.0	70.9	M18 x1.5	16	Form "AD"	3,30	WSCH/SCF16-105/SK50	5102085
SC16	3-16	40.0	135	52.0	100.9	M18 x1.5	16	Form "AD"	3,50	WSCH/SCF16-135/SK50	5102086
SC16	3-16	40.0	165	52.0	130.9	M18 x1.5	16	Form "AD"	3,80	WSCH/SCF16-165/SK50	5102087
SC20	6-20	48.0	105	59.5	70.9	M22 x1.5	16	Form "AD"	3,65	WSCH/SCF20-105/SK50	5102088
SC20	6-20	48.0	135	59.5	100.9	M22 x1.5	16	Form "AD"	3,85	WSCH/SCF20-135/SK50	5102089
SC20	6-20	48.0	165	59.5	130.9	M22 x1.5	16	Form "AD"	4,25	WSCH/SCF20-165/SK50	5102091
SC25	6-25	55.0	105	63.5	70.9	M28 x1.5	20	Form "AD"	3,40	WSCH/SCF25-105/SK50	5102092
SC25	6-25	55.0	135	63.5	100.9	M28 x1.5	20	Form "AD"	3,70	WSCH/SCF25-135/SK50	5102093
SC25	6-25	55.0	165	63.5	130.9	M28 x1.5	20	Form "AD"	4,00	WSCH/SCF25-165/SK50	5102095

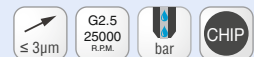

Ersatzteile und Zubehör / Spare Parts & Accessories: Pg.D8-D9 Pg.D10 Pg.D9 Pg.D19

• Im Lieferumfang enthalten: Spannmutter (gewuchtet) und Einstellschraube • Delivery includes: Clamping nut (friction type), Adjusting screw

Technische Details siehe Seite F6-F7 / For technical details please refer the instruction manual provided in the packing box or refer page F6-F7



Fräseraufnahme (Weldon) - für Zylinderschäfte gemäß DIN 1835 B  
 End mill holder (Weldon) - For cylindrical shanks according to DIN 1835B

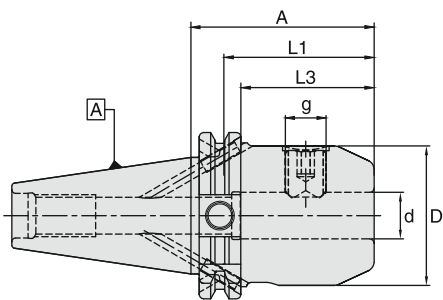

SK40

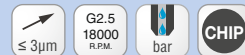

d (mm)	D (mm)	A (mm)	L1 (mm)	L3 (mm)	g	Kühlmittelzufuhr Coolant supply	N/W (Kg)	Bezeichnung Designation	Ident No.
16	48	35	49	15.9	M14	Form "AD"	0.85	WSLH/16-35/SK40*	4600771
20	50	35	51	15.9	M16	Form "AD"	1.10	WSLH/20-35/SK40*	4600782
25	50	35	59	15.9	M16 x1	Form "AD"	1.10	WSLH/25-35/SK40*	4600788
32	50	65	63	45.9	M16 x1	Form "AD"	1.25	WSLH/32-65/SK40*	4600792
06	25	50	37	30.9	M6	Form "AD/B"	1.05	WSLH/06-50/SK40	4600745
08	28	50	37	30.9	M8	Form "AD/B"	1.10	WSLH/08-50/SK40	4600750
10	35	50	41	30.9	M10	Form "AD/B"	1.15	WSLH/10-50/SK40	4600755
12	42	50	46	30.9	M12	Form "AD/B"	1.20	WSLH/12-50/SK40	4600760
14	44	50	46	30.9	M12	Form "AD/B"	1.20	WSLH/14-50/SK40	4600765
16	48	63	49	43.9	M14	Form "AD/B"	1.40	WSLH/16-63/SK40	4600770
18	50	63	49	43.9	M14	Form "AD/B"	1.45	WSLH/18-63/SK40	4600776
20	50	63	51	43.9	M16	Form "AD/B"	1.45	WSLH/20-63/SK40	4600781
06	25	100	37	80.9	M6	Form "AD/B"	1.20	WSLH/06-100/SK40	4600746
08	28	100	37	80.9	M8	Form "AD/B"	1.40	WSLH/08-100/SK40	4600751
10	35	100	41	80.9	M10	Form "AD/B"	1.45	WSLH/10-100/SK40	4600756
12	42	100	46	80.9	M12	Form "AD/B"	1.65	WSLH/12-100/SK40	4600761
14	44	100	46	80.9	M12	Form "AD/B"	1.75	WSLH/14-100/SK40	4600766
16	48	100	49	80.9	M14	Form "AD/B"	1.90	WSLH/16-100/SK40	4600772
18	50	100	49	80.9	M14	Form "AD/B"	1.95	WSLH/18-100/SK40	4600777
20	52	100	51	80.9	M16	Form "AD/B"	2.00	WSLH/20-100/SK40	4600783
25	65	100	59	80.9	M18 x2	Form "AD/B"	2.55	WSLH/25-100/SK40 **	4600787
32	72	100	63	80.9	M20 x2	Form "AD/B"	1.75	WSLH/32-100/SK40 **	4600791
40	80	120	73	100.9	M20 x2	Form "AD/B"	3.65	WSLH/40-120/SK40 **	4600795
06	25	160	37	140.9	M6	Form "AD/B"	1.75	WSLH/06-160/SK40 ❖	4600748
08	28	160	37	140.9	M8	Form "AD/B"	1.75	WSLH/08-160/SK40 ❖	4600753
10	35	160	41	140.9	M10	Form "AD/B"	2.00	WSLH/10-160/SK40 ❖	4600758
12	42	160	46	140.9	M12	Form "AD/B"	2.30	WSLH/12-160/SK40	4600763
14	44	160	46	140.9	M12	Form "AD/B"	2.40	WSLH/14-160/SK40	4600768
16	48	160	49	140.9	M14	Form "AD/B"	2.65	WSLH/16-160/SK40	4600774
18	50	160	49	140.9	M14	Form "AD/B"	2.80	WSLH/18-160/SK40	4600779
20	52	160	51	140.9	M16	Form "AD/B"	2.90	WSLH/20-160/SK40	4600785
25	65	160	59	140.9	M18 x2	Form "AD/B"	4.00	WSLH/25-160/SK40 **	4600789
32	72	160	63	140.9	M20 x2	Form "AD/B"	4.65	WSLH/32-160/SK40 **	4600793

Ersatzteile und Zubehör / Spare Parts & Accessories: Pg.D19

Pg.E2

- Datenträger-Bohrung (10mm) Standard bei allen Grundhaltern
- Bohrungstoleranz H4
- \* Extra kurze Aufnahmen:
  - Die Spannschrauben sind im Mitnehmer
  - Maximale Steifigkeit dank kurzer Ausraglänge
- Im Lieferumfang enthalten: Spannschraube
- Höhere Wuchtgüte auf Anfrage
- \*\* 2 Spannschrauben für ID Größe = 25 / 32 / 40
- ❖ Für WSLH/06-160/SK40, D2=47.6mm & L4=40mm
- Für WSLH/08-160/SK40, D2=46.2mm & L4=60mm
- Für WSLH/10-160/SK40, D2=52.0mm & L4=60mm

- Data carrier bore (10mm) as standard for all holders
- Bore tolerance H4
- \* Extra short holders:
  - Locking screws are located in the same plane as drive slots
  - Gives maximum rigidity due to short projection
- Delivery includes: Locking screw
- Higher balancing grade on request
- \*\* 2 locking screws for ID size = 25 / 32 / 40
- ❖ For WSLH/06-160/SK40, D2=47.6mm & L4=40mm
- For WSLH/08-160/SK40, D2=46.2mm & L4=60mm
- For WSLH/10-160/SK40, D2=52.0mm & L4=60mm

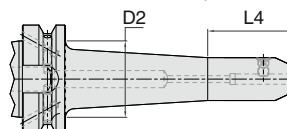

Fräseraufnahme (Weldon) - für Zylinderschäfte gemäß DIN 1835 B  
 End mill holder (Weldon) - For cylindrical shanks according to DIN 1835B

BT MAS 403  
ISO7388-2

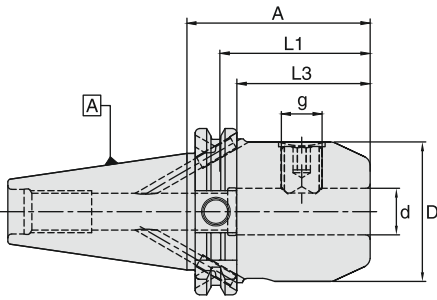

SK DIN 69871  
ISO7388-1

d (mm)	D (mm)	A (mm)	L1 (mm)	L3 (mm)	g	Kühlmittelzufuhr Coolant supply	N/W (Kg)	Bezeichnung Designation	Ident No.
06	25	63	37	43.9	M6	Form "AD/B"	2.80	WSLH/06-63/SK50	4601288
08	28	63	37	43.9	M8	Form "AD/B"	2.85	WSLH/08-63/SK50	4601292
10	35	63	41	43.9	M10	Form "AD/B"	2.95	WSLH/10-63/SK50	4601296
12	42	63	46	43.9	M12	Form "AD/B"	3.05	WSLH/12-63/SK50	4601300
14	44	63	46	43.9	M12	Form "AD/B"	3.10	WSLH/14-63/SK50	4601304
16	48	63	49	43.9	M14	Form "AD/B"	3.20	WSLH/16-63/SK50	4601308
18	50	63	49	43.9	M14	Form "AD/B"	3.20	WSLH/18-63/SK50	4601312
20	52	63	51	43.9	M16	Form "AD/B"	3.30	WSLH/20-63/SK50	4601316
25	65	80	59	60.9	M18 x2	Form "AD/B"	3.90	WSLH/25-80/SK50	4601320
06	25	100	37	80.9	M6	Form "AD/B"	2.95	WSLH/06-100/SK50	4601289
08	28	100	37	80.9	M8	Form "AD/B"	3.00	WSLH/08-100/SK50	4601293
10	35	100	41	80.9	M10	Form "AD/B"	3.20	WSLH/10-100/SK50	4601297
12	42	100	46	80.9	M12	Form "AD/B"	3.45	WSLH/12-100/SK50	4601301
14	44	100	46	80.9	M12	Form "AD/B"	3.50	WSLH/14-100/SK50	4601305
16	48	100	49	80.9	M14	Form "AD/B"	3.65	WSLH/16-100/SK50	4601309
18	50	100	49	80.9	M14	Form "AD/B"	3.80	WSLH/18-100/SK50	4601313
20	52	100	51	80.9	M16	Form "AD/B"	3.80	WSLH/20-100/SK50	4601317
25	65	120	59	100.9	M18 x2	Form "AD/B"	4.90	WSLH/25-120/SK50 **	4601321
32	72	100	63	80.9	M20 x2	Form "AD/B"	4.80	WSLH/32-100/SK50 **	4601324
40	80	100	73	80.9	M20 x2	Form "AD/B"	5.00	WSLH/40-100/SK50 **	5054934
06	25	160	37	140.9	M6	Form "AD/B"	3.35	WSLH/06-160/SK50 ❖	4601290
08	28	160	37	140.9	M8	Form "AD/B"	3.45	WSLH/08-160/SK50 ❖	4601294
10	35	160	41	140.9	M10	Form "AD/B"	3.85	WSLH/10-160/SK50 ❖	4601298
12	42	160	46	140.9	M12	Form "AD/B"	4.40	WSLH/12-160/SK50	4601302
14	44	160	46	140.9	M12	Form "AD/B"	4.20	WSLH/14-160/SK50	4601306
16	48	160	49	140.9	M14	Form "AD/B"	4.45	WSLH/16-160/SK50	4601310
18	50	160	49	140.9	M14	Form "AD/B"	4.60	WSLH/18-160/SK50	4601314
20	52	160	51	140.9	M16	Form "AD/B"	4.75	WSLH/20-160/SK50	4601318
25	65	160	59	140.9	M18 x2	Form "AD/B"	5.75	WSLH/25-160/SK50 **	4601322
32	72	160	63	140.9	M20 x2	Form "AD/B"	6.55	WSLH/32-160/SK50 **	4601325
40	80	160	73	140.9	M20 x2	Form "AD/B"	7.10	WSLH/40-160/SK50 **	4601328

HSK DIN 69893

Zubehör  
Accessories

Ersatzteile und Zubehör / Spare Parts & Accessories: :



- Datenträger-Bohrung (10 mm) Standard bei allen Grundhaltern
- Bohrungstoleranz H4
- Im Lieferumfang enthalten: Spannschraube
- Höhere Wuchtgüte auf Anfrage
- \*\* 2 Spannschrauben für ID Größe = 25 / 32 / 40
- ❖ Für WSLH/06-160/SK50, D2=41.8mm & L4=50mm  
Für WSLH/08-160/SK50, D2=48.6mm & L4=50mm  
Für WSLH/10-160/SK50, D2=54.3mm & L4=60mm

- Data carrier bore (10 mm) as standard for all holders
- Bore tolerance H4
- Delivery includes: Locking screw
- Higher balancing grade on request
- \*\* 2 locking screws for ID size = 25 / 32 / 40
- ❖ For WSLH/06-160/SK50, D2=41.8mm & L4=50mm  
For WSLH/08-160/SK50, D2=48.6mm & L4=50mm  
For WSLH/10-160/SK50, D2=54.3mm & L4=60mm

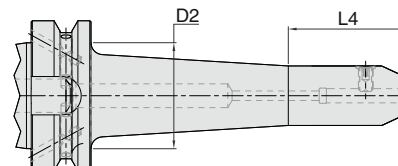

Ersatzteile  
Spare Parts

Technische Spezifikationen  
Technical Details

Fräseraufnahme DIN 6359 mit Kühlkanal - für Zylinderschäfte gemäß DIN 1835 B

End mill holder to DIN 6359 with coolant channel (For cylindrical shanks according to DIN 1835B)

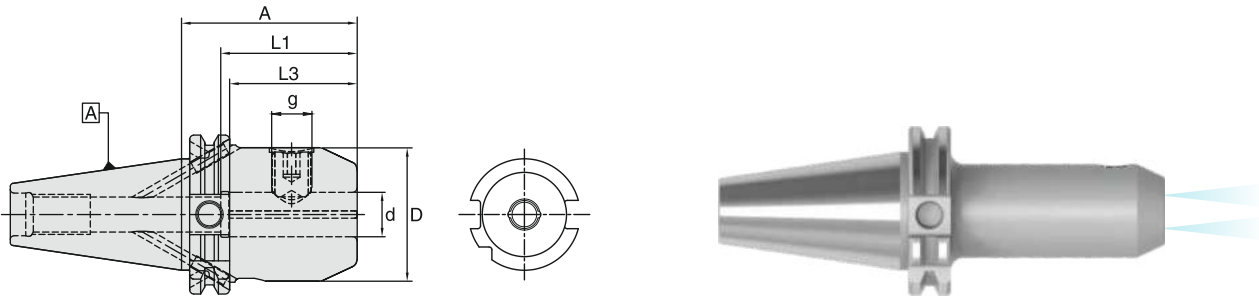

SK40									
d (mm)	D (mm)	A (mm)	L1 (mm)	L3 (mm)	g	Kühlmittelzufuhr Coolant supply	N/W (Kg)	Bezeichnung Designation	Ident No.
06	25	50	37	30.9	M6	Form "AD/B"	1.00	WSLH-K/06-50/SK40	4600749
08	28	50	37	30.9	M8	Form "AD/B"	1.00	WSLH-K/08-50/SK40	4600754
10	35	50	41	30.9	M10	Form "AD/B"	1.05	WSLH-K/10-50/SK40	4600759
12	42	50	46	30.9	M12	Form "AD/B"	1.15	WSLH-K/12-50/SK40	4600764
14	44	50	46	30.9	M12	Form "AD/B"	1.20	WSLH-K/14-50/SK40	4600769
16	48	63	49	43.9	M14	Form "AD/B"	1.40	WSLH-K/16-63/SK40	4600775
18	50	63	49	43.9	M14	Form "AD/B"	1.45	WSLH-K/18-63/SK40	4600780
20	50	63	51	43.9	M16	Form "AD/B"	1.45	WSLH-K/20-63/SK40	4600786
06	25	100	37	80.9	M6	Form "AD/B"	1.20	WSLH-K/06-100/SK40	4600747
08	28	100	37	80.9	M8	Form "AD/B"	1.25	WSLH-K/08-100/SK40	4600752
10	35	100	41	80.9	M10	Form "AD/B"	1.45	WSLH-K/10-100/SK40	4600757
12	42	100	46	80.9	M12	Form "AD/B"	1.70	WSLH-K/12-100/SK40	4600762
14	44	100	46	80.9	M12	Form "AD/B"	1.75	WSLH-K/14-100/SK40	4600767
16	48	100	49	80.9	M14	Form "AD/B"	1.90	WSLH-K/16-100/SK40	4600773
18	50	100	49	80.9	M14	Form "AD/B"	1.95	WSLH-K/18-100/SK40	4600778
20	52	100	51	80.9	M16	Form "AD/B"	2.05	WSLH-K/20-100/SK40	4600784
25	65	100	59	80.9	M18 x2	Form "AD/B"	2.55	WSLH-K/25-100/SK40 **	4600790
32	72	100	63	80.9	M20 x2	Form "AD/B"	2.75	WSLH-K/32-100/SK40 **	4600794
40	80	120	73	100.9	M20 x2	Form "AD/B"	3.25	WSLH-K/40-120/SK40 **	4600796

SK50									
d (mm)	D (mm)	A (mm)	L1 (mm)	L3 (mm)	g	Kühlmittelzufuhr Coolant supply	N/W (Kg)	Bezeichnung Designation	Ident No.
06	25	63	37	43.9	M6	Form "AD/B"	2.90	WSLH-K/06-63/SK50	4601291
08	28	63	37	43.9	M8	Form "AD/B"	2.95	WSLH-K/08-63/SK50	4601295
10	35	63	41	43.9	M10	Form "AD/B"	3.00	WSLH-K/10-63/SK50	4601299
12	42	63	46	43.9	M12	Form "AD/B"	3.10	WSLH-K/12-63/SK50	4601303
14	44	63	46	43.9	M12	Form "AD/B"	3.10	WSLH-K/14-63/SK50	4601307
16	48	63	49	43.9	M14	Form "AD/B"	3.25	WSLH-K/16-63/SK50	4601311
18	50	63	49	43.9	M14	Form "AD/B"	3.25	WSLH-K/18-63/SK50	4601315
20	52	63	51	43.9	M16	Form "AD/B"	3.30	WSLH-K/20-63/SK50	4601319
25	65	80	59	60.9	M18 x2	Form "AD/B"	3.90	WSLH-K/25-80/SK50 **	4601323
32	72	100	63	80.9	M20 x2	Form "AD/B"	4.75	WSLH-K/32-100/SK50 **	4601326
40	80	100	73	80.9	M20 x2	Form "AD/B"	4.95	WSLH-K/40-100/SK50 **	4601329

Ersatzteile und Zubehör / Spare Parts & Accessories: :



- Datenträger-Bohrung (10 mm) Standard bei allen Grundhaltern
- Bohrungstoleranz H4
- Extra kurze Aufnahmen:
  - Die Spannschrauben sind im Mitnehmer
  - Maximale Steifigkeit dank kurzer Auskraglänge
- Mit 2 Kühlkanälen entlang der Aufnahmebohrung versehen
- Im Lieferumfang enthalten: Spannschraube
- Höhere Wuchtgüte auf Anfrage

\*\* 2 Spannschrauben für ID Größe = 25 / 32 / 40

- Data carrier bore (10mm) as standard for all holders
- Bore tolerance H4
- Extra short holders:
  - Locking screws are located in the same plane as drive slots
  - Gives maximum rigidity due to short projection
- With two coolant channels along the side of the bore
- Delivery includes: Locking screw
- Higher balancing grade on request

\*\* 2 locking screws for ID size = 25 / 32 / 40

# Fräseraufnahme DIN 6359 Whistle Notch - für Zylinderschäfte gemäß DIN 1835 E

End mill holder to DIN 6359 Whistle Notch (For cylindrical shanks according to DIN 1835 E)

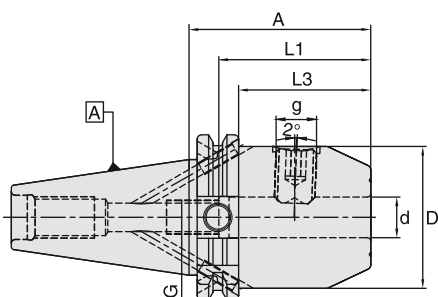

SK40



d (mm)	D (mm)	A (mm)	L1 (mm)	L3 (mm)	G	g	Kühlmittelezufuhr Coolant supply	N/W (Kg)	Bezeichnung Designation	Ident No.
06	25	50	37	30.9	M5	M6	Form "AD/B"	1.05	WSLH-E/06-50/SK40	4600797
08	28	50	37	30.9	M6	M8	Form "AD/B"	1.10	WSLH-E/08-50/SK40	4600798
10	35	50	41	30.9	M8	M10	Form "AD/B"	1.20	WSLH-E/10-50/SK40	4600799
12	42	50	46	30.9	M10	M12	Form "AD/B"	1.25	WSLH-E/12-50/SK40	4600800
14	44	50	46	30.9	M10	M12	Form "AD/B"	1.25	WSLH-E/14-50/SK40	4600801
16	48	63	49	43.9	M12	M14	Form "AD/B"	1.25	WSLH-E/16-63/SK40	4600802
18	50	63	49	43.9	M12	M14	Form "AD/B"	1.45	WSLH-E/18-63/SK40	4600803
20	50	63	51	43.9	M16	M16	Form "AD/B"	1.45	WSLH-E/20-63/SK40	4600804
25	65	100	59	80.9	M20	M18 x2	Form "AD/B"	2.50	WSLH-E/25-100/SK40 **	4600805
32	72	100	63	80.9	M20	M20 x2	Form "AD/B"	2.70	WSLH-E/32-100/SK40 **	4600806
40	80	120	73	100.9	M20	M20 x2	Form "AD/B"	3.65	WSLH-E/40-120/SK40 **	4600807

SK50



d (mm)	D (mm)	A (mm)	L1 (mm)	L3 (mm)	G	g	Kühlmittelezufuhr Coolant supply	N/W (Kg)	Bezeichnung Designation	Ident No.
06	25	63	37	43.9	M5	M6	Form "AD/B"	2.90	WSLH-E/06-63/SK50	4601330
08	28	63	37	43.9	M6	M8	Form "AD/B"	2.90	WSLH-E/08-63/SK50	4601331
10	35	63	41	43.9	M8	M10	Form "AD/B"	3.00	WSLH-E/10-63/SK50	4601332
12	42	63	46	43.9	M10	M12	Form "AD/B"	3.15	WSLH-E/12-63/SK50	4601333
14	44	63	46	43.9	M10	M12	Form "AD/B"	3.20	WSLH-E/14-63/SK50	4601334
16	48	63	49	43.9	M12	M14	Form "AD/B"	3.30	WSLH-E/16-63/SK50	4601335
18	50	63	49	43.9	M12	M14	Form "AD/B"	3.30	WSLH-E/18-63/SK50	4601336
20	52	63	51	43.9	M16	M16	Form "AD/B"	3.35	WSLH-E/20-63/SK50	4601337
25	65	80	59	60.9	M20	M18 x2	Form "AD/B"	4.00	WSLH-E/25-80/SK50 **	4601338
32	72	100	63	80.9	M20	M20 x2	Form "AD/B"	4.75	WSLH-E/32-100/SK50 **	4601339
40	80	100	73	80.9	M20	M20 x2	Form "AD/B"	5.00	WSLH-E/40-100/SK50 **	4601340

Ersatzteile und Zubehör / Spare Parts & Accessories: Pg.D19

Pg.E2

- Datenträger-Bohrung (10 mm) Standard bei allen Grundhaltern
- Bohrungstoleranz H4
- Stirnseitige Nut als Erkennungsmerkmal (im Unterschied zu Weldon)
- Im Lieferumfang enthalten: Spannschraube und Verstellechraube
- Höhere Wuchtgüte auf Anfrage
- \*\* 2 Spannschrauben für ID Größe = 25 / 32 / 40

- Data carrier bore (10 mm) as standard for all holders
- Bore tolerance H4
- Groove on face for easy identification (to distinguish from Weldon)
- Delivery includes: Locking screw & Adjusting screw
- Higher balancing grade on request
- \*\* 2 locking screws for ID size = 25 / 32 / 40

# Hochleistungsfräserspannfutter

## Hi-Power Milling Chuck

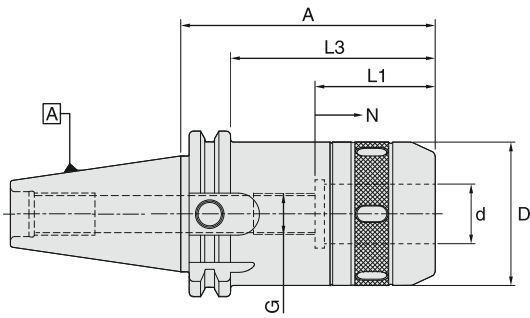

SK40										
d (mm)	D (mm)	A (mm)	L1 (mm)	L3 (mm)	G	N	Kühlmittelzufuhr Coolant supply	N/W (Kg)	Bezeichnung Designation	Ident No.
20	52	90	60	70.9	M12x1	15	Form "AD"	2.30	WHPMC/20-90/SK40	5058644
32	66	105	75	85.9	M16x1	15	Form "AD"	2.55	WHPMC/32-105/SK40	5055618



SK50										
d (mm)	D (mm)	A (mm)	L1 (mm)	L3 (mm)	G	N	Kühlmittelzufuhr Coolant supply	N/W (Kg)	Bezeichnung Designation	Ident No.
20	52	90	60	70.9	M12x1	15	Form "AD"	4.65	WHPMC/20-90/SK50	5058645
32	66	105	75	85.9	M16x1	15	Form "AD"	5.00	WHPMC/32-105/SK50	5055619



Ersatzteile und Zubehör / Spare Parts & Accessories: Pg.D12 Pg.D12 Pg.D19

Technische Details siehe Seite F4-F5 / For technical details please refer the instruction manual provided in the packing box or refer page F4-F5

# Mini-Spannzangenhalter

## Mini Collet Holder

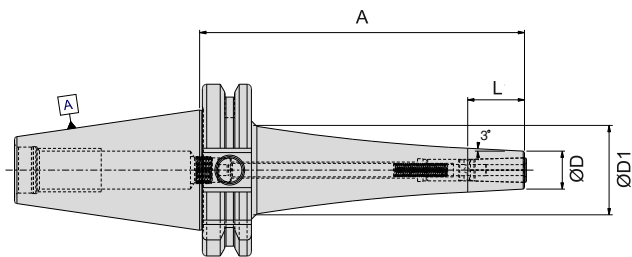

SK40										
Spannzange Collet Type	Bereich Range	A (mm)	L (mm)	D (mm)	D1 (mm)	Kühlmittelzufuhr Coolant supply	N/W (Kg)	Bezeichnung Designation	Ident No.	
MC14	3-6	90	21.0	14	29.0	-	1,0	WMCH/D14-90/SK40	66658759M	
MC14	3-6	120	21.0	14	33.0	-	1,1	WMCH/D14-120/SK40	66658760M	
MC14	3-6	150	21.0	14	42.0	-	1,4	WMCH/D14-150/SK40	66658761M	
MC21	6-12	90	31.5	21	36.0	-	1,1	WMCH/D21-90/SK40	66658770M	
MC21	6-12	120	31.5	21	43.9	-	1,5	WMCH/D21-120/SK40	66658771M	



Ersatzteile und Zubehör / Spare Parts & Accessories: Pg.D19 Pg.D16 Pg.D16 Pg.D16

Präzisions-Schnellspanbohrfutter  
Precision Keyless Drill Chuck

BT MAS 403  
ISO7388-2

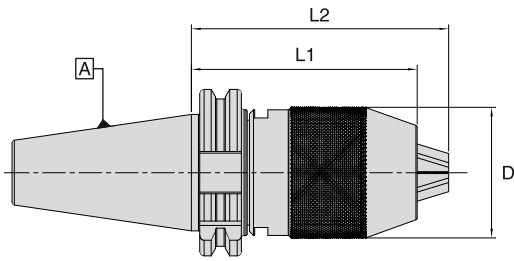

SK30							
D (mm)	L1 (mm)	L2 (mm)	Bereich Range	Kühlmittelezufuhr Coolant supply	N/W (Kg)	Bezeichnung Designation	Ident No.
50	117	129	1-13	-	1.58	WDC/1-13-117/SK30	66657337M

SK40							
D (mm)	A (mm)	L (mm)	Bereich Range	Kühlmittelezufuhr Coolant supply	N/W (Kg)	Bezeichnung Designation	Ident No.
50	86	98	1-13	-	1.72	WDC/1-13-86/SK40	66657338M

SK50							
D (mm)	A (mm)	L (mm)	Bereich Range	Kühlmittelezufuhr Coolant supply	N/W (Kg)	Bezeichnung Designation	Ident No.
50	84	96	1-13	-	3.38	WDC/1-13-84/SK50	66657339M

Original Albrecht design & licensed to Bilz

SK DIN 69871  
ISO7388-1

HSK DIN 69893

Zwischenhülsen für Morse-Kegel mit Anzugsgewinde DIN 6364 / 228A  
Adaptor sleeves for Morse taper with thread DIN 6364 / 228A

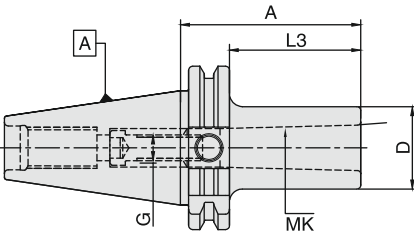

SK40								
MK	D (mm)	A (mm)	L3 (mm)	G	Kühlmittelezufuhr Coolant supply	N/W (Kg)	Bezeichnung Designation	Ident No.
1	25	50	30.9	M6	-	1.00	WMTB/MT1-50/SK40	4600706
2	32	50	30.9	M10	-	1.10	WMTB/MT2-50/SK40	4600707
3	40	70	50.9	M12	-	1.20	WMTB/MT3-70/SK40	4600708
4	48	95	75.9	M16	-	1.60	WMTB/MT4-95/SK40	4600709

SK50								
MK	D (mm)	A (mm)	L3 (mm)	G	Kühlmittelezufuhr Coolant supply	N/W (Kg)	Bezeichnung Designation	Ident No.
1	25	45	25.9	M6	-	2.80	WMTB/MT1-45/SK50	4601253
2	32	60	40.9	M10	-	2.90	WMTB/MT2-60/SK50	4601254
3	40	65	45.9	M12	-	2.95	WMTB/MT3-65/SK50	4601255
4	48	95	75.9	M16	-	3.30	WMTB/MT4-95/SK50	4601256
5	63	120	100.9	M20	-	3.70	WMTB/MT5-120/SK50	4601258

Ersatzteile und Zubehör / Spare Parts & Accessories: Pg.E5 Pg.D19 Pg.E5

- Datenträger-Bohrung (10 mm) Standard bei allen Grundhaltern
- Im Lieferumfang enthalten: eingebaute Innensechskantschraube
- Data carrier bore (10 mm) as std. for all holders
- Delivery includes: built-in draw screw

Zubehör  
Accessories

Ersatzteile  
Spare Parts

Technische Spezifikationen  
Technical Details

Zwischenhülsen für Morse-Kegel mit Austreibblappen DIN 6383  
 Adaptor sleeves for Morse taper with tang to DIN 6383

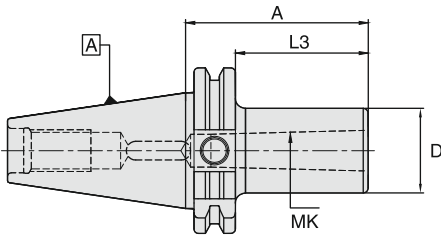

SK40							
MK	D (mm)	A (mm)	L3 (mm)	Kühlmittelzufuhr Coolant supply	N/W (Kg)	Bezeichnung Designation	Ident No.
1	25	50	30.9	-	1.00	WMTA/MT1-50/SK40	4600808
2	32	50	30.9	-	1.00	WMTA/MT2-50/SK40	4600809
3	40	70	50.9	-	1.20	WMTA/MT3-70/SK40	4600810
4	48	95	75.9	-	1.50	WMTA/MT4-95/SK40	4600811
2	32	117	97.9	-	1.50	WMTA/MT2-117/SK40	4600703
3	40	133	113.9	-	1.70	WMTA/MT3-133/SK40	4600704
4	48	156	136.9	-	2.20	WMTA/MT4-156/SK40	4600705



SK50							
MK	D (mm)	A (mm)	L3 (mm)	Kühlmittelzufuhr Coolant supply	N/W (Kg)	Bezeichnung Designation	Ident No.
1	25	45	25.9	-	2.70	WMTA/MT1-45/SK50	4601341
2	32	60	40.9	-	2.80	WMTA/MT2-60/SK50	4601342
3	40	65	45.9	-	2.90	WMTA/MT3-65/SK50	4601343
4	48	95	75.9	-	3.20	WMTA/MT4-95/SK50	4601344
5	70	105	85.9	-	3.80	WMTA/MT5-105/SK50	4601345
2	32	117	97.9	-	3.20	WMTA/MT2-117/SK50	4601249
3	40	137	117.9	-	3.40	WMTA/MT3-137/SK50	4601250
4	48	167	147.9	-	4.00	WMTA/MT4-167/SK50	4601251
5	70	195	175.9	-	6.20	WMTA/MT5-195/SK50	4601252



Ersatzteile und Zubehör / Spare Parts & Accessories: Pg.D19

- Datenträger-Bohrung (10 mm) Standard bei allen Grundhaltern
- Data carrier bore (10 mm) as standard for all holders

Aufnahme für Einschraubfräser  
Chuck for threaded milling heads

BT MAS 403  
ISO7388-2

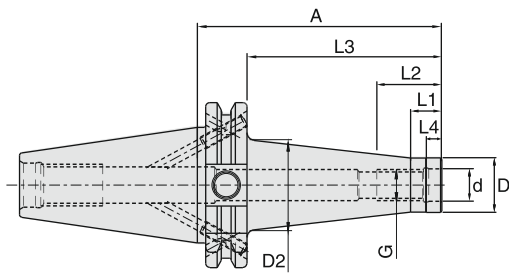

SK DIN 69871  
ISO7388-1

SK40												
G	d (mm)	D1 (mm)	D2 (mm)	A (mm)	L1 (mm)	L2 (mm)	L3 (mm)	L4 (mm)	Kühlmittelzufuhr Coolant supply	N/W (Kg)	Bezeichnung Designation	Ident No.
M6	6.5	10.0	13	44	12	16	24.9	6.5	Form "AD/B"	0.85	WTA/M6-44/SK40	5054973
M6	6.5	10.0	20	69	12	16	49.9	6.5	Form "AD/B"	0.90	WTA/M6-69/SK40	5054974
M6	6.5	10.0	23	94	12	16	74.9	6.5	Form "AD/B"	0.95	WTA/M6-94/SK40	5054975
M8	8.5	13.8	15	44	12	19	24.9	6.5	Form "AD/B"	0.85	WTA/M8-44/SK40	5054979
M8	8.5	13.8	23	69	12	19	49.9	6.5	Form "AD/B"	0.95	WTA/M8-69/SK40	5054980
M8	8.5	13.8	25	94	12	19	74.9	6.5	Form "AD/B"	1.00	WTA/M8-94/SK40	5054981
M8	8.5	13.8	30	119	12	19	99.9	6.5	Form "AD/B"	1.05	WTA/M8-119/SK40	5054982
M10	10.5	18.0	23	44	12	19	24.9	6.5	Form "AD/B"	0.90	WTA/M10-44/SK40	5054983
M10	10.5	18.0	25	69	12	19	49.9	6.5	Form "AD/B"	0.95	WTA/M10-69/SK40	5054985
M10	10.5	18.0	30	94	12	19	74.9	6.5	Form "AD/B"	1.00	WTA/M10-94/SK40	5054989
M10	10.5	18.0	35	119	12	19	99.9	6.5	Form "AD/B"	1.20	WTA/M10-119/SK40	5054991
M10	10.5	18.0	45	169	12	19	149.9	6.5	Form "AD/B"	1.70	WTA/M10-169/SK40	5054992
M12	12.5	21.0	24	44	12	25	24.9	7.0	Form "AD/B"	0.80	WTA/M12-44/SK40	5054993
M12	12.5	21.0	30	69	12	25	49.9	7.0	Form "AD/B"	1.00	WTA/M12-69/SK40	5054995
M12	12.5	21.0	35	94	12	25	74.9	7.0	Form "AD/B"	1.15	WTA/M12-94/SK40	5054996
M12	12.5	21.0	38	119	12	25	99.9	7.0	Form "AD/B"	1.20	WTA/M12-119/SK40	5054997
M12	12.5	21.0	48	169	12	25	149.9	7.0	Form "AD/B"	1.90	WTA/M12-169/SK40	5054998
M16	17.0	29.0	29	44	12	31	24.9	8.0	Form "AD/B"	0.95	WTA/M16-44/SK40	5054999
M16	17.0	29.0	34	69	12	31	49.9	8.0	Form "AD/B"	1.10	WTA/M16-69/SK40	5055001
M16	17.0	29.0	35	94	12	31	74.9	8.0	Form "AD/B"	1.25	WTA/M16-94/SK40	5055002
M16	17.0	29.0	40	119	12	31	99.9	8.0	Form "AD/B"	1.50	WTA/M16-119/SK40	5055003
M16	17.0	29.0	48	169	12	31	149.9	8.0	Form "AD/B"	2.10	WTA/M16-169/SK40	5055004

HSK DIN 69893

Zubehör  
Accessories

SK50												
G	d (mm)	D1 (mm)	D2 (mm)	A (mm)	L1 (mm)	L2 (mm)	L3 (mm)	L4 (mm)	Kühlmittelzufuhr Coolant supply	N/W (Kg)	Bezeichnung Designation	Ident No.
M8	8.5	13.8	23	69	12	19	49.9	6.5	Form "AD/B"	2.70	WTA/M8-69/SK50	5055005
M8	8.5	13.8	30	119	12	19	99.9	6.5	Form "AD/B"	2.90	WTA/M8-119/SK50	5055007
M8	8.5	13.8	45	169	12	19	149.9	6.5	Form "AD/B"	3.30	WTA/M8-169/SK50	5055011
M10	10.5	18.0	25	69	12	19	49.9	6.5	Form "AD/B"	2.70	WTA/M10-69/SK50	5055012
M10	10.5	18.0	35	119	12	19	99.9	6.5	Form "AD/B"	3.00	WTA/M10-119/SK50	5055013
M10	10.5	18.0	45	169	12	19	149.9	6.5	Form "AD/B"	3.40	WTA/M10-169/SK50	5055014
M12	12.5	21.0	30	69	12	25	49.9	7.0	Form "AD/B"	2.80	WTA/M12-69/SK50	5055016
M12	12.5	21.0	38	119	12	25	99.9	7.0	Form "AD/B"	3.10	WTA/M12-119/SK50	5055017
M12	12.5	21.0	52	169	12	25	149.9	7.0	Form "AD/B"	3.70	WTA/M12-169/SK50	5055018
M16	17.0	29.0	34	69	12	31	49.9	8.0	Form "AD/B"	2.90	WTA/M16-69/SK50	5055019
M16	17.0	29.0	40	119	12	31	99.9	8.0	Form "AD/B"	3.20	WTA/M16-119/SK50	5055022
M16	17.0	29.0	48	169	12	31	149.9	8.0	Form "AD/B"	3.90	WTA/M16-169/SK50	5055023

Ersatzteile  
Spare Parts

Ersatzteile und Zubehör / Spare Parts & Accessories: Pg.D19

Siehe Seite D14 für Einschraubfräser Verlängerung & Reduzierung  
Refer page. D14 for Threaded Arbor extensions & reductions.

Technische Spezifikationen  
Technical Details



Aufsteckfräserdorne DIN 6358 mit Längs- und Quernut (Kombi)  
Shell mill holder with DIN 6358 (Combi)

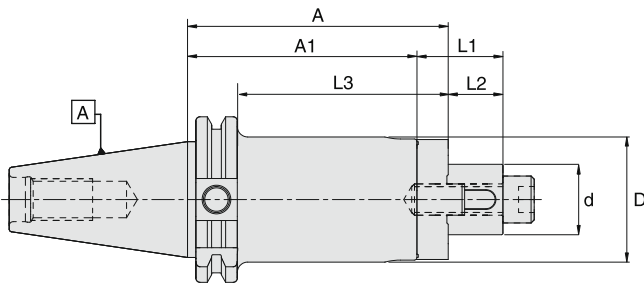

SK40										
d (mm)	D (mm)	A (mm)	A1 (mm)	L1 (mm)	L2 (mm)	L3 (mm)	Kühlmittelzufuhr Coolant supply	N/W (Kg)	Bezeichnung Designation	Ident No.
16	32	55	45	27	17	35.9	-	1.25	WFSH/16-55/SK40	4600812
22	40	55	43	31	19	35.9	-	1.35	WFSH/22-55/SK40	4600814
27	48	55	43	33	21	35.9	-	1.60	WFSH/27-55/SK40	4600816
32	58	60	46	38	24	40.9	-	1.90	WFSH/32-60/SK40	4600818
40	70	60	46	41	27	40.9	-	2.20	WFSH/40-60/SK40	4600820
16	32	100	90	27	17	80.9	-	1.50	WFSH/16-100/SK40	4600813
22	40	100	88	31	19	80.9	-	1.80	WFSH/22-100/SK40	4600815
27	48	100	88	33	21	80.9	-	2.20	WFSH/27-100/SK40	4600817
32	58	100	86	38	24	80.9	-	2.70	WFSH/32-100/SK40	4600819
40	70	100	86	41	27	80.9	-	3.30	WFSH/40-100/SK40 **	4600821



SK50										
d (mm)	D (mm)	A (mm)	A1 (mm)	L1 (mm)	L2 (mm)	L3 (mm)	Kühlmittelzufuhr Coolant supply	N/W (Kg)	Bezeichnung Designation	Ident No.
16	32	55	45	27	17	35.9	-	3.00	WFSH/16-55/SK50	4601346
22	40	55	43	31	19	35.9	-	3.20	WFSH/22-55/SK50	4601348
27	48	55	43	33	21	35.9	-	3.40	WFSH/27-55/SK50	4601350
32	58	55	41	38	24	35.9	-	3.70	WFSH/32-55/SK50	4601352
40	70	55	41	41	27	35.9	-	4.10	WFSH/40-55/SK50	4601354
50	90	70	54	46	30	50.9	-	5.80	WFSH/50-70/SK50	5054972
16	32	100	90	27	17	80.9	-	3.30	WFSH/16-100/SK50	4601347
22	40	100	88	31	19	80.9	-	3.60	WFSH/22-100/SK50	4601349
27	48	100	88	33	21	80.9	-	4.00	WFSH/27-100/SK50	4601351
32	58	100	86	38	24	80.9	-	4.50	WFSH/32-100/SK50	4601353
40	70	100	86	41	27	80.9	-	5.50	WFSH/40-100/SK50 **	4601355



Ersatzteile und Zubehör / Spare Parts & Accessories: Pg.E3 Pg.E4 Pg.E3 Pg.D21 Pg.D19

- Datenträger-Bohrung (10 mm) Standard bei allen Grundhaltern
- Im Lieferumfang enthalten: Passfeder, Mitnehmerring, Fräseranzugsschraube und Spannschrauben (DIN 912)
- Spannschrauben bitte separat bestellen (DIN 6367)
- \*\* Im Lieferumfang enthalten: Spannschrauben (DIN 6367)
- Data carrier bore (10 mm) as standard for all holders
- Delivery includes: Parallel key, drive ring, clamping screw and locking screw (DIN 912)
- Please order locking screw (DIN 6367) separately
- \*\* Delivery includes: Locking screw (DIN 6367)

Aufnahmedorn mit Innenzentrierung DIN 6357 mit vergrößertem Bunddurchmesser  
Shell mill holder DIN 6357 for cutters with drive key

BT MAS 403  
ISO7388-2

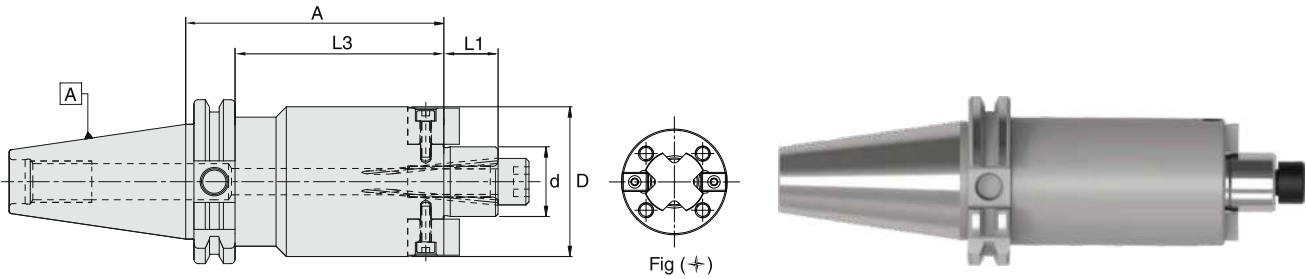

SK DIN 69871  
ISO7388-1

**SK40**

d (mm)	D (mm)	A (mm)	L1 (mm)	L3 (mm)	Kühlmittelezufuhr Coolant supply	N/W (Kg)	Bezeichnung Designation	Ident No.
16	38	35	17	15.9	Form "AD/B"	1.10	WSMH/16-35/SK40	4600822
22	48	35	19	15.9	Form "AD/B"	1.25	WSMH/22-35/SK40	4600823
27	50	40	21	20.9	Form "AD/B"	1.45	WSMH/27-40/SK40	4600824
32	78	50	24	30.9	Form "AD/B"	2.00	WSMH/32-50/SK40	4600825
40	88	50	27	30.9	Form "AD/B"	2.30	WSMH/40-50/SK40+	4600826
16	38	100	17	80.9	Form "AD/B"	1.70	WSMH/16-100/SK40	5055095
22	48	100	19	80.9	Form "AD/B"	2.20	WSMH/22-100/SK40	5055102
27	58	100	21	80.9	Form "AD/B"	2.70	WSMH/27-100/SK40	5055104
32	78	100	24	80.9	Form "AD/B"	3.80	WSMH/32-100/SK40	5055105
40	88	100	27	80.9	Form "AD/B"	4.50	WSMH/40-100/SK40+	5055106
16	38	160	17	140.9	Form "AD/B"	2.20	WSMH/16-160/SK40	5055107
22	48	160	19	140.9	Form "AD/B"	3.00	WSMH/22-160/SK40	5055108
27	58	160	21	140.9	Form "AD/B"	3.85	WSMH/27-160/SK40	5055109
32	78	160	24	140.9	Form "AD/B"	5.90	WSMH/32-160/SK40	5055110
40	88	160	27	140.9	Form "AD/B"	7.30	WSMH/40-160/SK40+	5055111

HSK DIN 69893

**SK50**

d (mm)	D (mm)	A (mm)	L1 (mm)	L3 (mm)	Kühlmittelezufuhr Coolant supply	N/W (Kg)	Bezeichnung Designation	Ident No.
16	38	44	17	24.9	Form "AD/B"	2.95	WSMH/16-44/SK50	5055112
22	48	44	19	24.9	Form "AD/B"	3.10	WSMH/22-44/SK50	4601356
27	58	44	21	24.9	Form "AD/B"	3.35	WSMH/27-44/SK50	4601357
32	78	40	24	20.9	Form "AD/B"	3.65	WSMH/32-40/SK50	4601358
40	88	50	27	30.9	Form "AD/B"	5.70	WSMH/40-50/SK50+	4601359
60	129	70	40	50.9	-	7.80	WSMH/60-70/SK50+	4601360
16	38	100	17	80.9	Form "AD/B"	3.50	WSMH/16-100/SK50	5055123
22	48	100	19	80.9	Form "AD/B"	3.85	WSMH/22-100/SK50	5055125
27	58	100	21	80.9	Form "AD/B"	4.90	WSMH/27-100/SK50	5055126
32	78	100	24	80.9	Form "AD/B"	5.80	WSMH/32-100/SK50	5055127
40	88	100	27	80.9	Form "AD/B"	6.70	WSMH/40-100/SK50+	5055128
16	38	160	17	140.9	Form "AD/B"	3.95	WSMH/16-160/SK50	5055130
22	48	160	19	140.9	Form "AD/B"	4.70	WSMH/22-160/SK50	5055131
27	58	160	21	140.9	Form "AD/B"	5.85	WSMH/27-160/SK50	5055132
32	78	160	24	140.9	Form "AD/B"	8.00	WSMH/32-160/SK50	5055133
40	88	160	27	140.9	Form "AD/B"	9.50	WSMH/40-160/SK50+	5055134

Zubehör  
Accessories

Ersatzteile und Zubehör / Spare Parts & Accessories: Pg.D21 Pg.E3 Pg.E4 Pg.D19 Pg.E4

- Datenträger-Bohrung (10 mm) Standard bei allen Grundhaltern
- Kühlbohrung an der Stirnseite Standard bei allen Grundhaltern
- + ID = Ø 40, d = Ø 60 Mit 4 zusätzlichen Gewindebohrungen nach DIN 2079 und Spanschrauben (DIN 6367) für Ø40
- Im Lieferumfang enthalten: Mitnehmersteine und Innensechskantschraube (DIN 912)
- Spanschrauben (DIN 6367) bitte separat bestellen (Siehe Seite E3)
- Data carrier bore (10 mm) as standard for all holders
- Coolant bore on the pilot face (holder with Form "AD/B") as standard for all holders
- + ID = Ø 40, d = Ø 60 with additional 4 screw holes to DIN 2079 and with locking screw (DIN 6367) for Ø40
- Delivery includes: Drive keys and socket head screw to DIN 912
- Please order locking screw (DIN 6367) separately (refer page E3)

Ersatzteile  
Spare Parts

Technische Spezifikationen  
Technical Details

## Zwischenhülsen Reduction Sleeves

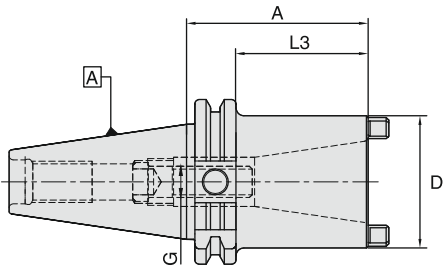

SK40								
Innenkegelgröße Inside Taper	D (mm)	A (mm)	L3 (mm)	G	Kühlmittelezufuhr Coolant supply	N/W (Kg)	Bezeichnung Designation	Ident No.
SK 30	51	50	30.9	M12	-	1.30	SK40-SK30-50	4600711
SK 40	63	100	80.9	M16	-	2.30	SK40-SK40-100	4600712

SK50								
Innenkegelgröße Inside Taper	D (mm)	A (mm)	L3 (mm)	G	Kühlmittelezufuhr Coolant supply	N/W (Kg)	Bezeichnung Designation	Ident No.
SK 40	70	80	60.9	M16	-	4.30	SK50-SK40-80	4601260
SK 50	100	120	100.9	M24	-	6.40	SK50-SK50-120	4601261

Ersatzteile und Zubehör / Spare Parts & Accessories: Pg.E7 Pg.D19 Pg.E7

- Datenträger-Bohrung (10mm) Standard bei allen Grundhaltern
- Im Lieferumfang enthalten: eingebaute Innensechskantschraube
- Data carrier bore (10 mm) as standard for all holders
- Delivery includes: built-in draw screw

## Bohrstangenrohlinge Boring bar blanks

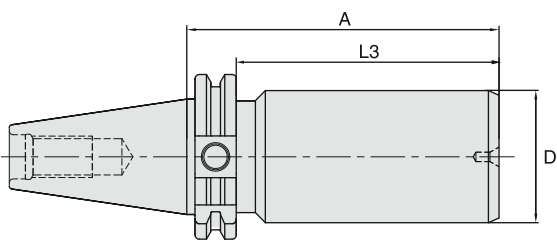

SK40							
D (mm)	A (mm)	L3 (mm)	Kühlmittelezufuhr Coolant supply	N/W (Kg)	Bezeichnung Designation	Ident No.	
63	250	230.9	"AD/B"	6.40	WBBB/63-250/SK40	4600725	

SK50							
D (mm)	A (mm)	L3 (mm)	Kühlmittelezufuhr Coolant supply	N/W (Kg)	Bezeichnung Designation	Ident No.	
63.5	300	280.9	"AD/B"	9.60	WBBB/63.5-300/SK50	4601272	

- Im Lieferumfang enthalten: Steilkegel und Bund gehärtet und geschliffen, Schaft weich zur weiteren Bearbeitung
- Delivery includes: Steep taper and flange hardened and ground, body left soft

Kontrolldorn  
Test Arbor

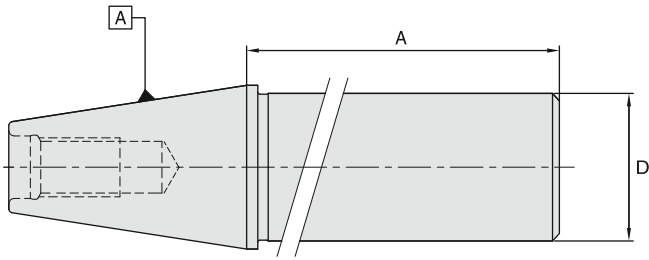

SK40 <span style="float: right;">↗ ≤ 2µm</span>					
D (mm)	A (mm)	Kühlmittelzufuhr Coolant supply	N/W (Kg)	Bezeichnung Designation	Ident No.
40	330	-	3.15	WTMM/40-330/SK40	5056226

SK50 <span style="float: right;">↗ ≤ 2µm</span>					
D (mm)	A (mm)	Kühlmittelzufuhr Coolant supply	N/W (Kg)	Bezeichnung Designation	Ident No.
50	330	-	7.60	WTMM/50-330/BT50	5056227

- Diese Dorne haben keinen Bund
- Kontrolldorne werden im Holzkasten geliefert.

- These gauge are without flange
- Delivered in wooden box

Spannzangenfutter ER Collet chuck ER	C2 - C4
Super collet Spannzangenfutter Super collet chuck	C5
Fräseraufnahmen (Weldon & Whistle Notch) End mill holder (Weldon & Whistle Notch)	C6 - C10
Hochleistungsfräuserspannfutter Hi-power milling chuck	C11 - C12
Mini-Spannzangenhalter Mini Collet Holder	C13
Hydrodehnspannfutter Hydraulic expansion chuck	C13 - C14
Präzisions-Bohrfutter Precision drill chuck	C15
Aufnahmen für Morse-Kegel Morse taper holder (with thread & tang)	C15 - C16
Aufnahmen für Einschraubfräser Chuck for threaded milling heads	C17
Kombi-Aufsteckfräserdorn Combi shell mill holder	C18
Messerkopf-Aufnahme Shell mill holder	C19 - C20
Bohrstangenrohlinge Boring bar blanks	C21
Kontrolldorn Test Arbor	C22

Spannzangenfutter Typ ER für Spannzangen DIN 6499  
Collet chuck type ER for collets to DIN 6499

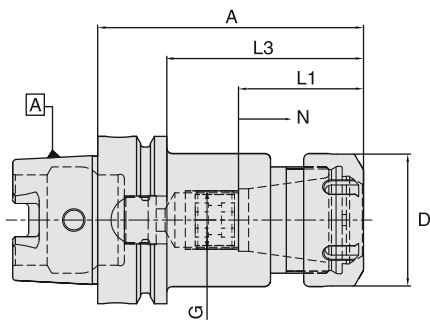

HSK-A32											
Spannzange Collet Type	Bereich Range	D (mm)	A (mm)	L1 (mm)	L3 (mm)	G	N	Kühlmittelezufuhr Coolant supply	N/W (Kg)	Bezeichnung Designation	Ident No.
ER16M	1-10	22	65	33.5	45	M10	8	Form "AD"	0.35	WCCH/ER16M-65/HSK-A32	9202350
ER20M	1-13	28	70	38.0	50	M10	8	Form "AD"	0.40	WCCH/ER20M-70/HSK-A32	5068528
ER25M	2-16	35	70	41.0	50	M10	8	Form "AD"	0.70	WCCH/ER25M-70/HSK-A32	9202351



HSK-A40											
Spannzange Collet Type	Bereich Range	D (mm)	A (mm)	L1 (mm)	L3 (mm)	G	N	Kühlmittelezufuhr Coolant supply	N/W (Kg)	Bezeichnung Designation	Ident No.
ER16M	1-10	22	70	33.5	50	M10	12	Form "AD"	0.40	WCCH/ER16M-70/HSK-A40	9202352
ER20	1-13	34	80	38.0	60	M12	12	Form "AD"	0.55	WCCH/ER20-80/HSK-A40	5068534
ER25	2-16	42	80	41.0	60	M16	12	Form "AD"	0.60	WCCH/ER25-80/HSK-A40	5068535
ER32	2-20	50	100	47.0	80	M22X1.5	12	Form "AD"	0.80	WCCH/ER32-100/HSK-A40	9202354
ER16M	1-10	22	120	33.5	100	M10	12	Form "AD"	0.60	WCCH/ER16M-120/HSK-A40	9202355
ER20M	1-13	28	120	38.0	100	M12	12	Form "AD"	0.65	WCCH/ER20M-120/HSK-A40	5068538
ER25M	2-16	35	120	41.0	100	M16	12	Form "AD"	0.70	WCCH/ER25M-120/HSK-A40	9202356

HSK-A50											
Spannzange Collet Type	Bereich Range	D (mm)	A (mm)	L1 (mm)	L3 (mm)	G	N	Kühlmittelezufuhr Coolant supply	N/W (Kg)	Bezeichnung Designation	Ident No.
ER16M	1-10	22	80	33.5	54	M10	12	Form "AD"	0.60	WCCH/ER16M-80/HSK-A50	9202357
ER16	1-10	28	80	32.5	54	M10	12	Form "AD"	0.53	WCCH/ER16-80/HSK-A50	66612144M
ER20	1-13	34	95	38.0	69	M12	12	Form "AD"	0.90	WCCH/ER20-95/HSK-A50	5068540
ER25	2-16	42	95	41.0	69	M16	12	Form "AD"	1.10	WCCH/ER25-95/HSK-A50	9202358
ER16	1-10	28	100	32.5	74	M10	12	Form "AD"	0.62	WCCH/ER16-100/HSK-A50	66658858M
ER32	2-20	50	100	47.0	74	M22X1.5	12	Form "AD"	1.20	WCCH/ER32-100/HSK-A50	5056308

HSK-A63											
Spannzange Collet Type	Bereich Range	D (mm)	A (mm)	L1 (mm)	L3 (mm)	G	N	Kühlmittelezufuhr Coolant supply	N/W (Kg)	Bezeichnung Designation	Ident No.
ER11	1-10	19	75	23.5	49	M6	12	Form "AD"	0.72	WCCH/ER11-75/HSK-A63	5157492
ER16	1-10	28	75	32.5	49	M10	12	Form "AD"	0.81	WCCH/ER16-75/HSK-A63	5156946
ER20	1-13	34	75	38.0	49	-	12	Form "AD"	0.85	WCCH/ER20-75/HSK-A63	5160936
ER25	2-16	42	75	41.0	49	-	12	Form "AD"	0.97	WCCH/ER25-75/HSK-A63	5156963
ER32	2-20	50	80	47.0	59	M10	12	Form "AD"	1.14	WCCH/ER32-80/HSK-A63	5156973
ER40	3-26	63	85	58.5	59	-	12	Form "AD"	1.28	WCCH/ER40-85/HSK-A63	5156974
ER11	1-10	19	100	23.5	74	M6	12	Form "AD"	0.77	WCCH/ER11-100/HSK-A63	5157493
ER16M	1-10	22	100	34.0	74	M10	12	Form "AD"	0.86	WCCH/ER16M-100/HSK-A63	5055257
ER16	1-10	28	100	32.5	74	M10	12	Form "AD"	0.92	WCCH/ER16-100/HSK-A63	5160937
ER20	1-13	34	100	38.0	74	M12	12	Form "AD"	1.20	WCCH/ER20-100/HSK-A63	5055258
ER25	2-16	42	100	41.0	74	M16	12	Form "AD"	1.40	WCCH/ER25-100/HSK-A63	4601696
ER32	2-20	50	100	47.0	74	M22X1.5	12	Form "AD"	1.50	WCCH/ER32-100/HSK-A63	4601698
ER40	3-26	63	120	58.5	94	M22X1.5	12	Form "AD"	2.00	WCCH/ER40-120/HSK-A63	4601700



Ersatzteile und Zubehör / Spare Parts & Accessories: Pg.D2-D4 Pg.D5 Pg.D7 Pg.D21

- Kühlmittelrohr bitte separat bestellen (Siehe Seite D20)
- Im Lieferumfang enthalten: Spannmutter (gewuchtet) und Einstellschraube
- Please order coolant tube separately (Refer page D20)
- Delivery includes: Clamping nut (balanced)

Spannzangenfutter Typ ER für Spannzangen DIN 6499  
Collet chuck type ER for collets to DIN 6499

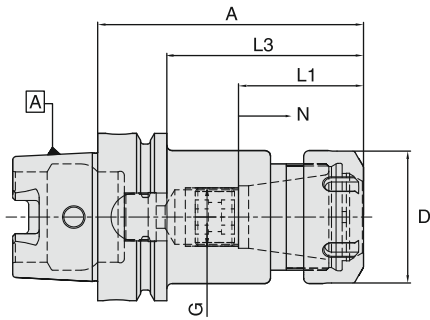

**HSK-A32**

Spannzange Collet Type	Bereich Range	D (mm)	A (mm)	L1 (mm)	L3 (mm)	G	N	Kühlmittelezufuhr Coolant supply	N/W (Kg)	Bezeichnung Designation	Ident No.
ER16M	1-10	22	65	33.5	45	M10	8	Form "AD"	0.35	WCCH/ER16M-65/HSK-A32	9202350
ER20M	1-13	28	70	38.0	50	M10	8	Form "AD"	0.40	WCCH/ER20M-70/HSK-A32	5068528
ER25M	2-16	35	70	41.0	50	M10	8	Form "AD"	0.70	WCCH/ER25M-70/HSK-A32	9202351

**HSK-A40**

Spannzange Collet Type	Bereich Range	D (mm)	A (mm)	L1 (mm)	L3 (mm)	G	N	Kühlmittelezufuhr Coolant supply	N/W (Kg)	Bezeichnung Designation	Ident No.
ER16M	1-10	22	70	33.5	50	M10	12	Form "AD"	0.40	WCCH/ER16M-70/HSK-A40	9202352
ER20	1-13	34	80	38.0	60	M12	12	Form "AD"	0.55	WCCH/ER20-80/HSK-A40	5068534
ER25	2-16	42	80	41.0	60	M16	12	Form "AD"	0.60	WCCH/ER25-80/HSK-A40	5068535
ER32	2-20	50	100	47.0	80	M22X1.5	12	Form "AD"	0.80	WCCH/ER32-100/HSK-A40	9202354
ER16M	1-10	22	120	33.5	100	M10	12	Form "AD"	0.60	WCCH/ER16M-120/HSK-A40	9202355
ER20M	1-13	28	120	38.0	100	M12	12	Form "AD"	0.65	WCCH/ER20M-120/HSK-A40	5068538
ER25M	2-16	35	120	41.0	100	M16	12	Form "AD"	0.70	WCCH/ER25M-120/HSK-A40	9202356

**HSK-A50**

Spannzange Collet Type	Bereich Range	D (mm)	A (mm)	L1 (mm)	L3 (mm)	G	N	Kühlmittelezufuhr Coolant supply	N/W (Kg)	Bezeichnung Designation	Ident No.
ER16M	1-10	22	80	33.5	54	M10	12	Form "AD"	0.60	WCCH/ER16M-80/HSK-A50	9202357
ER20	1-13	34	95	38.0	69	M12	12	Form "AD"	0.90	WCCH/ER20-95/HSK-A50	5068540
ER25	2-16	42	95	41.0	69	M16	12	Form "AD"	1.10	WCCH/ER25-95/HSK-A50	9202358
ER32	2-20	50	100	47.0	74	M22X1.5	12	Form "AD"	1.20	WCCH/ER32-100/HSK-A50	5056308

**HSK-A63**

Spannzange Collet Type	Bereich Range	D (mm)	A (mm)	L1 (mm)	L3 (mm)	G	N	Kühlmittelezufuhr Coolant supply	N/W (Kg)	Bezeichnung Designation	Ident No.
ER11	1-10	19	75	23.5	49	M6	12	Form "AD"	0.72	WCCH/ER11-75/HSK-A63	5157492
ER16	1-10	28	75	32.5	49	M10	12	Form "AD"	0.81	WCCH/ER16-75/HSK-A63	5156946
ER20	1-13	34	75	38.0	49	-	12	Form "AD"	0.85	WCCH/ER20-75/HSK-A63	5160936
ER25	2-16	42	75	41.0	49	-	12	Form "AD"	0.97	WCCH/ER25-75/HSK-A63	5156963
ER32	2-20	50	80	47.0	59	M10	12	Form "AD"	1.14	WCCH/ER32-80/HSK-A63	5156973
ER40	3-26	63	85	58.5	59	-	12	Form "AD"	1.28	WCCH/ER40-85/HSK-A63	5156974
ER11	1-10	19	100	23.5	74	M6	12	Form "AD"	0.77	WCCH/ER11-100/HSK-A63	5157493
ER16M	1-10	22	100	34.0	74	M10	12	Form "AD"	0.86	WCCH/ER16M-100/HSK-A63	5055257
ER16	1-10	28	100	32.5	74	M10	12	Form "AD"	0.92	WCCH/ER16-100/HSK-A63	5160937
ER20	1-13	34	100	38.0	74	M12	12	Form "AD"	1.20	WCCH/ER20-100/HSK-A63	5055258
ER25	2-16	42	100	41.0	74	M16	12	Form "AD"	1.40	WCCH/ER25-100/HSK-A63	4601696
ER32	2-20	50	100	47.0	74	M22X1.5	12	Form "AD"	1.50	WCCH/ER32-100/HSK-A63	4601698
ER40	3-26	63	120	58.5	94	M22X1.5	12	Form "AD"	2.00	WCCH/ER40-120/HSK-A63	4601700

Ersatzteile und Zubehör / Spare Parts & Accessories:

Pg.D2-D4    
 Pg.D5    
 Pg.D7    
 Pg.D21

- Kühlmittelrohr bitte separat bestellen (Siehe Seite D20)
- Im Lieferumfang enthalten: Spannmutter (gewuchtet) und Einstellschraube
- Please order coolant tube separately (Refer page D20)
- Delivery includes: Clamping nut (balanced)

Spannzangenfutter Typ ER für Spannzangen DIN 6499  
Collet chuck type ER for collets to DIN 6499

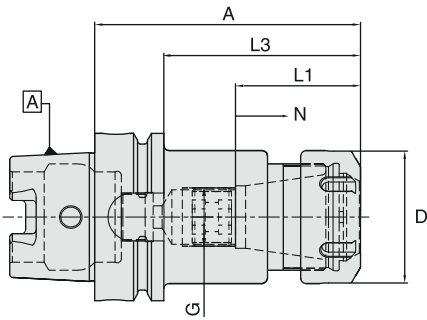

HSK-A63											
Spannzange Collet Type	Bereich Range	D (mm)	A (mm)	L1 (mm)	L3 (mm)	G	N	Kühlmittelezufuhr Coolant supply	N/W (Kg)	Bezeichnung Designation	Ident No.
ER16M	1-10	22	160	34.0	134	M10	12	Form "AD"	1.30	WCCH/ER16M-160/HSK-A63*	5055261
ER16	1-10	28	160	32.5	134	M10	12	Form "AD"	1.40	WCCH/ER16-160/HSK-A63	5160938
ER20M	1-13	28	160	38.0	134	M12	12	Form "AD"	1.40	WCCH/ER20M-160/HSK-A63*	5055262
ER20	1-13	34	160	38.0	134	M12	12	Form "AD"	1.65	WCCH/ER20-160/HSK-A63	5160939
ER25M	2-16	35	160	41.0	134	M16	12	Form "AD"	1.80	WCCH/ER25M-160/HSK-A63*	5055263
ER25	2-16	42	160	41.0	134	M16	12	Form "AD"	1.95	WCCH/ER25-160/HSK-A63	5160940
ER32	2-20	50	160	47.0	134	M22X1.5	12	Form "AD"	2.40	WCCH/ER32-160/HSK-A63	4601699
ER40	3-26	63	160	58.5	134	M22X1.5	12	Form "AD"	2.50	WCCH/ER40-160/HSK-A63	4601701

HSK-A100											
Spannzange Collet Type	Bereich Range	D (mm)	A (mm)	L1 (mm)	L3 (mm)	G	N	Kühlmittelezufuhr Coolant supply	N/W (Kg)	Bezeichnung Designation	Ident No.
ER16	1-10	28	100	32.5	71	M10	12	Form "AD"	2.45	WCCH/ER16-100/HSK-A100	5160941
ER20	1-13	34	100	38.0	71	M12	12	Form "AD"	2.50	WCCH/ER20-100/HSK-A100	5055502
ER25	2-16	42	100	41.0	71	M16	12	Form "AD"	2.70	WCCH/ER25-100/HSK-A100	4601611
ER32	2-20	50	100	47.0	71	M22X1.5	12	Form "AD"	2.90	WCCH/ER32-100/HSK-A100	4601612
ER40	3-26	63	120	58.5	91	M22X1.5	12	Form "AD"	3.20	WCCH/ER40-120/HSK-A100	4601613
ER16	1-10	28	160	32.5	131	M10	12	Form "AD"	2.75	WCCH/ER16-160/HSK-A100	5160942
ER20	1-13	34	160	38.0	131	M12	12	Form "AD"	2.90	WCCH/ER20-160/HSK-A100	5055504
ER25	2-16	42	160	41.0	131	M16	12	Form "AD"	3.30	WCCH/ER25-160/HSK-A100	5055506
ER32	2-20	50	160	47.0	131	M22X1.5	12	Form "AD"	3.65	WCCH/ER32-160/HSK-A100	5055507
ER40	3-26	63	160	58.5	131	M22X1.5	12	Form "AD"	3.80	WCCH/ER40-160/HSK-A100	5055508

HSK-A100											
Spannzange Collet Type	Bereich Range	D (mm)	A (mm)	L1 (mm)	L3 (mm)	G	N	Kühlmittelezufuhr Coolant supply	N/W (Kg)	Bezeichnung Designation	Ident No.
ER20	1-13	34	200	38.0	171	M12	12	Form "AD"	2.94	WCCH/ER20-200/HSK-A100	66658669M
ER25	2-16	42	200	41.0	171	M16	12	Form "AD"	3.56	WCCH/ER25-200/HSK-A100	66658671M
ER32	2-20	50	200	47.0	171	M22X1.5	12	Form "AD"	4.13	WCCH/ER32-200/HSK-A100	66658673M
ER20	1-13	34	250	38.0	221	M12	12	Form "AD"	3.23	WCCH/ER20-250/HSK-A100	66658670M
ER25	2-16	42	250	41.0	221	M16	12	Form "AD"	4.04	WCCH/ER25-250/HSK-A100	66658672M
ER32	2-20	50	250	47.0	221	M22X1.5	12	Form "AD"	4.85	WCCH/ER32-250/HSK-A100	66658674M
ER32	2-20	50	450	47.0	421	M22X1.5	12	Form "AD"	10.83	WCCH/ER32-450/HSK-A100	66658675M

Ersatzteile und Zubehör / Spare Parts & Accessories:



Pg.D2-D4



Pg.D5



Pg.D7



Pg.D21

\* Gemäß Kegelausführung

- Kühlmittelrohr bitte separat bestellen (Siehe Seite D20)
- Im Lieferumfang enthalten: Spannmutter (gewuchtet) und Einstellschraube

❖ Für..

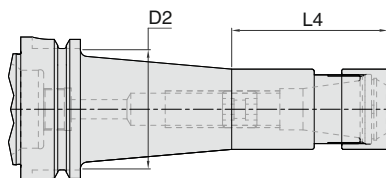

\* As per taper design

- Please order coolant tube separately (Refer page D20)
- Delivery includes: Clamping nut (balanced) & adjusting screw

❖ Note: For WCCH/ER16M-160/HSK-A63, D2=41mm & L4=58mm  
For WCCH/ER25M-160/HSK-A63, D2=52mm & L4=88mm  
For WCCH/ER32-450/HSK-A100, D2=80mm & L4=195mm



# Super collet Spannzangenfutter

## Super collet chuck

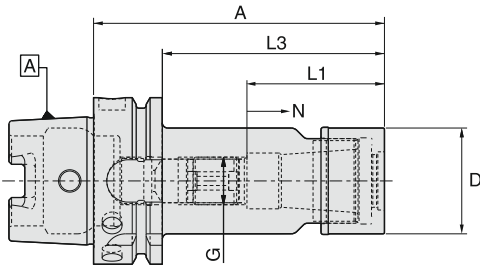

HSK-A50											
Spannzange Collet Type	Bereich Range	D (mm)	A (mm)	L1 (mm)	L3 (mm)	G (mm)	N (mm)	Kühlmittelezufuhr Coolant supply	N/W (Kg)	Bezeichnung Designation	Ident No.
SC06	2-6	19.5	80	31.5	54	M8 x1	12	Form "AD"	0,70	WSCH/SCF06-80/HSK-A50	5102129
SC10	2-10	27.1	100	35.0	74	M12 x1	12	Form "AD"	0,80	WSCH/SCF10-100/HSK-A50	5102130
SC13	3-13	33.0	100	43.0	74	M15 x1	16	Form "AD"	0,80	WSCH/SCF13-100/HSK-A50	5102131



HSK-A63											
Spannzange Collet Type	Bereich Range	D (mm)	A (mm)	L1 (mm)	L3 (mm)	G (mm)	N (mm)	Kühlmittelezufuhr Coolant supply	N/W (Kg)	Bezeichnung Designation	Ident No.
SC06	2-6	19.5	100	31.5	74	M8 x1	12	Form "AD"	0,95	WSCH/SCF06-100/HSK-A63	5102132
SC06	2-6	19.5	120	31.5	94	M8 x1	12	Form "AD"	1,10	WSCH/SCF06-120/HSK-A63	5102133
SC06	2-6	19.5	150	31.5	124	M8 x1	12	Form "AD"	1,15	WSCH/SCF06-150/HSK-A63	5102134
SC10	2-10	27.1	105	35.0	79	M12 x1	12	Form "AD"	1,05	WSCH/SCF10-105/HSK-A63	5102135
SC10	2-10	27.1	120	35.0	94	M12 x1	12	Form "AD"	1,15	WSCH/SCF10-120/HSK-A63	5102136
SC10	2-10	27.1	150	35.0	124	M12 x1	12	Form "AD"	1,30	WSCH/SCF10-150/HSK-A63	5102137
SC13	3-13	33.0	120	43.0	94	M15 x1	16	Form "AD"	1,25	WSCH/SCF13-120/HSK-A63	5102138
SC13	3-13	33.0	150	43.0	124	M15 x1	16	Form "AD"	1,45	WSCH/SCF13-150/HSK-A63	5102141
SC16	3-16	40.0	120	52.0	94	M18 x1.5	16	Form "AD"	1,50	WSCH/SCF16-120/HSK-A63	5102142
SC16	3-16	40.0	150	52.0	124	M18 x1.5	16	Form "AD"	1,80	WSCH/SCF16-150/HSK-A63	5102143
SC20	6-20	48.0	120	59.5	94	M22 x1.5	16	Form "AD"	1,80	WSCH/SCF20-120/HSK-A63	5102144
SC20	6-20	48.0	150	59.5	124	M22 x1.5	16	Form "AD"	2,10	WSCH/SCF20-150/HSK-A63	5102145
SC25	6-25	55.0	135	63.5	109	M28 x1.5	20	Form "AD"	2,30	WSCH/SCF25-135/HSK-A63	5102146

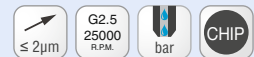

HSK-A100											
Spannzange Collet Type	Bereich Range	D (mm)	A (mm)	L1 (mm)	L3 (mm)	G (mm)	N (mm)	Kühlmittelezufuhr Coolant supply	N/W (Kg)	Bezeichnung Designation	Ident No.
SC06	2-6	19.5	105	31.5	76	M8 x1	12	Form "AD"	2,30	WSCH/SCF06-105/HSK-A100	5102188
SC10	2-10	27.1	105	35.0	76	M12 x1	12	Form "AD"	2,35	WSCH/SCF10-105/HSK-A100	5102189
SC10	2-10	27.1	120	35.0	91	M12 x1	12	Form "AD"	2,50	WSCH/SCF10-120/HSK-A100	5102190
SC10	2-10	27.1	150	35.0	121	M12 x1	12	Form "AD"	2,60	WSCH/SCF10-150/HSK-A100	5102191
SC13	3-13	33.0	120	43.0	91	M15 x1	16	Form "AD"	2,65	WSCH/SCF13-120/HSK-A100	5102192
SC13	3-13	33.0	150	43.0	121	M15 x1	16	Form "AD"	2,80	WSCH/SCF13-150/HSK-A100	5102193
SC16	3-16	40.0	120	52.0	91	M18 x1.5	16	Form "AD"	2,85	WSCH/SCF16-120/HSK-A100	5102194
SC16	3-16	40.0	150	52.0	121	M18 x1.5	16	Form "AD"	3,10	WSCH/SCF16-150/HSK-A100	5102195
SC20	6-20	48.0	120	59.5	91	M22 x1.5	16	Form "AD"	3,10	WSCH/SCF20-120/HSK-A100	5102196
SC20	6-20	48.0	150	59.5	121	M22 x1.5	16	Form "AD"	3,50	WSCH/SCF20-150/HSK-A100	5102197
SC25	6-25	55.0	145	63.5	116	M28 x1.5	20	Form "AD"	3,60	WSCH/SCF25-145/HSK-A100	5102198

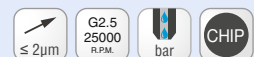

Ersatzteile und Zubehör / Spare Parts & Accessories: Pg.D8-D9 Pg.D10 Pg.D9 Pg.D21

- Im Lieferumfang enthalten: Spannmutter (gewuchtet) und Einstellschraube
- Kühlmittelrohr bitte separat bestellen (Siehe Seite D21)
- Delivery includes: Clamping nut (friction type), Adjusting screw
- Please order coolant tube separately (Refer page D21)

Technische Details siehe Seite F6-F7 / For technical details please refer the instruction manual provided in the packing box or refer page F6-F7

Fräseraufnahmen (Weldon) - für Zylinderschäfte gemäß DIN 1835 B  
 End mill holder (Weldon) - For cylindrical shanks according to DIN 1835 B

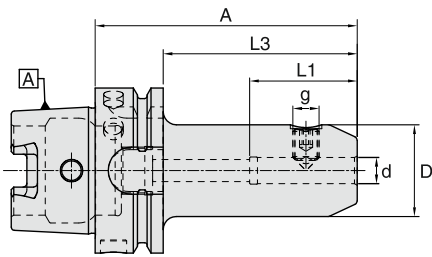

HSK-A32									
d (mm)	D (mm)	A (mm)	L1 (mm)	L3 (mm)	g	Kühlmittelezufuhr Coolant supply	N/W (Kg)	Bezeichnung Designation	Ident No.
06	25	60	37	40	M6	Form "AD"	0.40	WSLH/06-60/HSK-A32	9202366
08	28	60	37	40	M8	Form "AD"	0.40	WSLH/08-60/HSK-A32	9202367
10	35	65	41	45	M10	Form "AD"	0.45	WSLH/10-65/HSK-A32	9202368
12	42	75	46	55	M12	Form "AD"	0.65	WSLH/12-75/HSK-A32	9202369
16	48	75	49	55	M14	Form "AD"	0.75	WSLH/16-75/HSK-A32	9202370



HSK-A40									
d (mm)	D (mm)	A (mm)	L1 (mm)	L3 (mm)	g	Kühlmittelezufuhr Coolant supply	N/W (Kg)	Bezeichnung Designation	Ident No.
06	25	60	37	40	M6	Form "AD"	0.50	WSLH/06-60/HSK-A40	9202371
08	28	60	37	40	M8	Form "AD"	0.50	WSLH/08-60/HSK-A40	9202372
10	34	65	41	45	M10	Form "AD"	0.60	WSLH/10-65/HSK-A40	9202373
12	42	70	46	50	M12	Form "AD"	0.80	WSLH/12-70/HSK-A40	9202374
16	48	80	49	60	M14	Form "AD"	0.90	WSLH/16-80/HSK-A40	9202375
20	52	80	51	60	M16	Form "AD"	1.00	WSLH/20-80/HSK-A40	9202376



HSK-A50									
d (mm)	D (mm)	A (mm)	L1 (mm)	L3 (mm)	g	Kühlmittelezufuhr Coolant supply	N/W (Kg)	Bezeichnung Designation	Ident No.
06	25	65	37	39	M6	Form "AD"	0.65	WSLH/06-65/HSK-A50	9202377
08	28	65	37	39	M8	Form "AD"	0.70	WSLH/08-65/HSK-A50	9202378
10	35	65	41	39	M10	Form "AD"	0.75	WSLH/10-65/HSK-A50	9202379
12	42	80	46	54	M12	Form "AD"	1.05	WSLH/12-80/HSK-A50	9202380
16	48	80	49	54	M14	Form "AD"	1.10	WSLH/16-80/HSK-A50	9202381
20	52	80	51	54	M16	Form "AD"	1.10	WSLH/20-80/HSK-A50	9202382
25	62.5	105	59	79	M18 x2	Form "AD"	1.85	WSLH/25-105/HSK-A50 **	9202383
32	72	120	63	94	M20 x2	Form "AD"	2.75	WSLH/32-120/HSK-A50 **	9202384

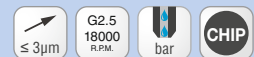

Ersatzteile und Zubehör / Spare Parts & Accessories: Pg.E2 Pg.D21

- Bohrungstoleranz H4
- Kühlmittelrohr bitte separat bestellen (Siehe Seite D21)
- Im Lieferumfang enthalten: Spannschraube
- \*\* 2 Spannschrauben für ID Größe = 25 / 32 / 40
- Bore tolerance H4
- Please order coolant tube separately (Refer page D21)
- Delivery includes: Locking screw
- \*\* 2 locking screws for ID size = 25 / 32 / 40

Fräseraufnahmen (Weldon) - für Zylinderschäfte gemäß DIN 1835 B  
 End mill holder (Weldon) - For cylindrical shanks according to DIN 1835 B

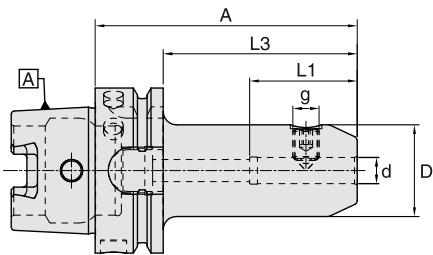

HSK-A63									
d (mm)	D (mm)	A (mm)	L1 (mm)	L3 (mm)	g	Kühlmittelzufuhr Coolant supply	N/W (Kg)	Bezeichnung Designation	Ident No.
06	25	65	37	39	M6	Form "AD"	0.95	WSLH/06-65/HSK-A63	4601702
08	28	65	37	39	M8	Form "AD"	0.95	WSLH/08-65/HSK-A63	4601705
10	35	65	41	39	M10	Form "AD"	1.00	WSLH/10-65/HSK-A63	4601708
12	42	80	46	54	M12	Form "AD"	1.25	WSLH/12-80/HSK-A63	4601711
14	44	80	46	54	M12	Form "AD"	1.30	WSLH/14-80/HSK-A63	4601715
16	48	80	49	54	M14	Form "AD"	1.50	WSLH/16-80/HSK-A63	4601719
18	50	80	49	54	M14	Form "AD"	1.40	WSLH/18-80/HSK-A63	4601723
20	52	80	51	54	M16	Form "AD"	1.60	WSLH/20-80/HSK-A63	4601727
06	25	100	37	74	M6	Form "AD"	1.10	WSLH/06-100/HSK-A63	4601703
08	28	100	37	74	M8	Form "AD"	1.15	WSLH/08-100/HSK-A63	4601706
10	35	100	41	74	M10	Form "AD"	1.26	WSLH/10-100/HSK-A63	4601709
12	42	100	46	74	M12	Form "AD"	1.50	WSLH/12-100/HSK-A63	5056629
16	48	100	49	74	M14	Form "AD"	1.75	WSLH/16-100/HSK-A63	5056632
20	52	100	51	74	M16	Form "AD"	1.90	WSLH/20-100/HSK-A63	5065495
25	62.5	110	59	84	M18 x2	Form "AD"	2.45	WSLH/25-110/HSK-A63 **	4601730
32	72	110	63	84	M20 x2	Form "AD"	2.80	WSLH/32-110/HSK-A63 **	4601732
40	80	125	73	99	M20 x2	Form "AD"	3.40	WSLH/40-125/HSK-A63 **	4601734



HSK-A63									
d (mm)	D (mm)	A (mm)	L1 (mm)	L3 (mm)	g	Kühlmittelzufuhr Coolant supply	N/W (Kg)	Bezeichnung Designation	Ident No.
06	25	160	37	134	M6	Form "AD"	1.45	WSLH/06-160/HSK-A63 ❖	5056636
08	28	160	37	134	M8	Form "AD"	1.55	WSLH/08-160/HSK-A63 ❖	5056638
10	35	160	41	134	M10	Form "AD"	1.90	WSLH/10-160/HSK-A63 ❖	5056640
12	42	160	46	134	M12	Form "AD"	2.20	WSLH/12-160/HSK-A63	5056642
16	48	160	49	134	M14	Form "AD"	2.60	WSLH/16-160/HSK-A63	5056643
20	52	160	51	134	M16	Form "AD"	2.85	WSLH/20-160/HSK-A63	5056645



Ersatzteile und Zubehör / Spare Parts & Accessories: Pg.E2 Pg.D21

- Bohrungstoleranz H4
- Kühlmittelrohr bitte separat bestellen (Siehe Seite D21)
- Im Lieferumfang enthalten: Spannschraube
- \*\* 2 Spannschrauben für ID Größe = 25 / 32 / 40
- ❖ Für WSLH/06-160/HSK-A63, D2=44.7mm & L4=50mm  
 For WSLH/08-160/HSK-A63, D2=44.0mm & L4=50mm  
 For WSLH/10-160/HSK-A63, D2=49.7mm & L4=60mm

- Bore tolerance H4
- Please order coolant tube separately (Refer page D21)
- Delivery includes: Locking screw
- \*\* 2 locking screws for ID size = 25 / 32 / 40
- ❖ Note: For WSLH/06-160/HSK-A63, D2=44.7mm & L4=50mm  
 For WSLH/08-160/HSK-A63, D2=44.0mm & L4=50mm  
 For WSLH/10-160/HSK-A63, D2=49.7mm & L4=60mm

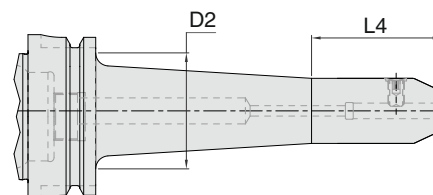

Fräseraufnahmen (Weldon) - für Zylinderschäfte gemäß DIN 1835 B  
 End mill holder (Weldon) - For cylindrical shanks according to DIN 1835 B

BT MAS 403  
 ISO7388-2

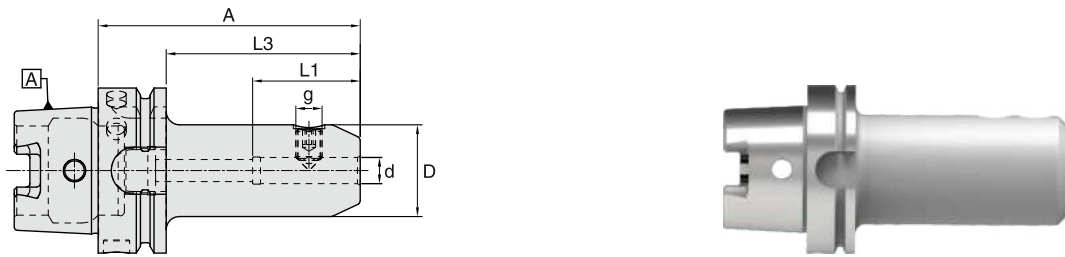

SK DIN 69871  
 ISO7388-1

HSK-A100									
d (mm)	D (mm)	A (mm)	L1 (mm)	L3 (mm)	g	Kühlmittelzufuhr Coolant supply	N/W (Kg)	Bezeichnung Designation	Ident No.
06	25	80	37	51	M6	Form "AD"	2.37	WSLH/06-80/HSK-A100	4601614
08	28	80	37	51	M8	Form "AD"	2.35	WSLH/08-80/HSK-A100	4601616
10	35	80	41	51	M10	Form "AD"	2.50	WSLH/10-80/HSK-A100	4601618
12	42	80	46	51	M12	Form "AD"	2.70	WSLH/12-80/HSK-A100	4601620
14	44	80	46	51	M12	Form "AD"	2.70	WSLH/14-80/HSK-A100	4601622
16	48	100	49	71	M14	Form "AD"	3.05	WSLH/16-100/HSK-A100	4601624
18	50	100	49	71	M14	Form "AD"	3.10	WSLH/18-100/HSK-A100	4601626
20	52	100	51	71	M16	Form "AD"	3.25	WSLH/20-100/HSK-A100	4601628
25	65	100	59	71	M18 x2	Form "AD"	3.80	WSLH/25-100/HSK-A100 **	4601630
32	72	100	63	71	M20 x2	Form "AD"	3.95	WSLH/32-100/HSK-A100 **	4601632
40	80	105	73	76	M20 x2	Form "AD"	4.40	WSLH/40-105/HSK-A100 **	4601634

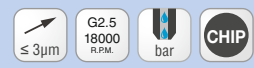

HSK DIN 69893

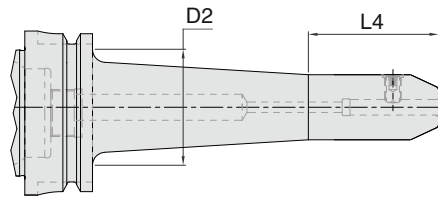

HSK-A100											
d (mm)	D (mm)	D2 (mm)	A (mm)	L1 (mm)	L3 (mm)	L4 (mm)	g	Kühlmittelzufuhr Coolant supply	N/W (Kg)	Bezeichnung Designation	Ident No.
06	25	55.1	160	37	131	50	M6	Form "AD"	2.95	WSLH/06-160/HSK-A100	5056735
08	28	58.1	160	37	131	50	M8	Form "AD"	3.05	WSLH/08-160/HSK-A100	5056736
10	35	61.2	160	41	131	65	M10	Form "AD"	3.35	WSLH/10-160/HSK-A100	5056737
12	42	69.5	160	46	131	60	M12	Form "AD"	3.85	WSLH/12-160/HSK-A100	5056739
16	48	72.9	160	49	131	70	M14	Form "AD"	4.20	WSLH/16-160/HSK-A100	5056740
20	52	79.5	160	51	131	60	M16	Form "AD"	4.60	WSLH/20-160/HSK-A100	5056742
25	65	83.7	160	59	131	80	M18 x2	Form "AD"	5.55	WSLH/25-160/HSK-A100 **	5056743
32	72	-	160	63	131	-	M20 x2	Form "AD"	5.65	WSLH/32-160/HSK-A100 **	5160943
40	80	-	160	73	131	-	M20 x2	Form "AD"	6.22	WSLH/40-160/HSK-A100 **	66658869M

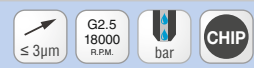

Zubehör  
 Accessories

Ersatzteile  
 Spare Parts

Ersatzteile und Zubehör / Spare Parts & Accessories: Pg.E2 Pg.D20

- Bohrungstoleranz H4
- Kühlmittelrohr bitte separat bestellen (Siehe Seite D21)
- Im Lieferumfang enthalten: Spannschraube
- \*\* 2 Spannschrauben für ID Größe = 25 / 32 / 40
- Bore tolerance H4
- Please order coolant tube separately (Refer page D21)
- Delivery includes: Locking screw
- \*\* 2 locking screws for ID size = 25 / 32 / 40

Technische Spezifikationen  
 Technical Details

# Fräseraufnahmen DIN 6359 mit Kühlkanal - für Zylinderschäfte gemäß DIN 1835 B

End mill holder to DIN 6359 with coolant channel (For cylindrical shanks according to DIN 1835 B)

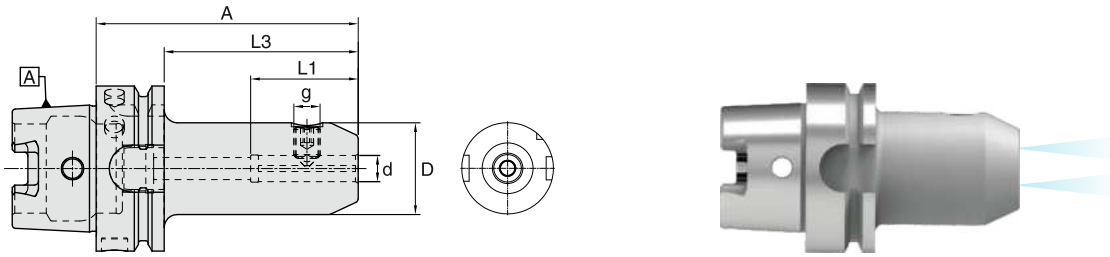

HSK-A63									
d (mm)	D (mm)	A (mm)	L1 (mm)	L3 (mm)	g	Kühlmittelzufuhr Coolant supply	N/W (Kg)	Bezeichnung Designation	Ident No.
06	25	65	37	39	M6	Form "AD"	0.95	WSLH-K/06-65/HSK-A63	4601704
08	28	65	37	39	M8	Form "AD"	0.95	WSLH-K/08-65/HSK-A63	4601707
10	35	65	41	39	M10	Form "AD"	1.00	WSLH-K/10-65/HSK-A63	4601710
12	42	80	46	54	M12	Form "AD"	1.25	WSLH-K/12-80/HSK-A63	4601714
14	44	80	46	54	M12	Form "AD"	1.30	WSLH-K/14-80/HSK-A63	4601718
16	48	80	49	54	M14	Form "AD"	1.50	WSLH-K/16-80/HSK-A63	4601722
18	50	80	49	54	M14	Form "AD"	1.40	WSLH-K/18-80/HSK-A63	4601726
20	52	80	51	54	M16	Form "AD"	1.65	WSLH-K/20-80/HSK-A63	4601729
25	62.5	110	59	84	M18 x2	Form "AD"	2.45	WSLH-K/25-110/HSK-A63 **	4601731
32	72	110	63	84	M20 x2	Form "AD"	2.80	WSLH-K/32-110/HSK-A63 **	4601733
40	80	125	73	99	M20 x2	Form "AD"	3.40	WSLH-K/40-125/HSK-A63 **	4601735

HSK-A100									
d (mm)	D (mm)	A (mm)	L1 (mm)	L3 (mm)	g	Kühlmittelzufuhr Coolant supply	N/W (Kg)	Bezeichnung Designation	Ident No.
06	25	80	37	51	M6	Form "AD"	2.30	WSLH-K/06-80/HSK-A100	4601615
08	28	80	37	51	M8	Form "AD"	2.40	WSLH-K/08-80/HSK-A100	4601617
10	35	80	41	51	M10	Form "AD"	2.50	WSLH-K/10-80/HSK-A100	4601619
12	42	80	46	51	M12	Form "AD"	2.55	WSLH-K/12-80/HSK-A100	4601621
14	44	80	46	51	M12	Form "AD"	2.70	WSLH-K/14-80/HSK-A100	4601623
16	48	100	49	71	M14	Form "AD"	3.00	WSLH-K/16-100/HSK-A100	4601625
18	50	100	49	71	M14	Form "AD"	3.05	WSLH-K/18-100/HSK-A100	4601627
20	52	100	51	71	M16	Form "AD"	3.15	WSLH-K/20-100/HSK-A100	4601629
25	65	100	59	71	M18 x2	Form "AD"	3.70	WSLH-K/25-100/HSK-A100 **	4601631
32	72	100	63	71	M20 x2	Form "AD"	3.95	WSLH-K/32-100/HSK-A100 **	4601633
40	80	105	73	76	M20 x2	Form "AD"	4.35	WSLH-K/40-105/HSK-A100 **	4601635

Ersatzteile und Zubehör / Spare Parts & Accessories:



Pg.E2



Pg.D21

- Bohrungstoleranz H4
- Kühlmittelrohr bitte separat bestellen (Siehe Seite D21)
- Mit 2 Kühlkanälen entlang der Aufnahmebohrung versehen
- Im Lieferumfang enthalten: Spannschraube
- \*\* 2 Spannschrauben für ID Größe = 25 / 32 / 40

- Bore tolerance H4
- Please order coolant tube separately (Refer page D21)
- With two coolant channels along the side of the bore
- Delivery includes: Locking screw
- \*\* 2 locking screws for ID size = 25 / 32 / 40

Fräseraufnahmen DIN 6359 Whistle Notch - für Zylinderschäfte gemäß DIN 1835 E  
 End mill holder to DIN 6359 Whistle Notch (For cylindrical shanks according to DIN 1835 E)

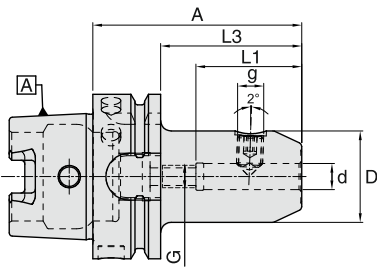

**HSK-A63**

d (mm)	D (mm)	A (mm)	L1 (mm)	L3 (mm)	G	g	Kühlmittelzufuhr Coolant supply	N/W (Kg)	Bezeichnung Designation	Ident No.
06	25	80	36.5	54	M5	M6	Form "AD"	1.00	WSLH-E/06-80/HSK-A63	4601736
08	28	80	36.5	54	M6	M8	Form "AD"	1.00	WSLH-E/08-80/HSK-A63	4601737
10	35	80	40.5	54	M8	M10	Form "AD"	1.05	WSLH-E/10-80/HSK-A63	4601738
12	42	90	45.5	64	M10	M12	Form "AD"	1.30	WSLH-E/12-90/HSK-A63	4601739
14	44	90	45.5	64	M10	M12	Form "AD"	1.35	WSLH-E/14-90/HSK-A63	4601740
16	48	100	48.5	74	M12	M14	Form "AD"	1.55	WSLH-E/16-100/HSK-A63	4601741
18	50	100	48.5	74	M12	M14	Form "AD"	1.45	WSLH-E/18-100/HSK-A63	4601742
20	52	100	50.5	74	M16	M16	Form "AD"	1.70	WSLH-E/20-100/HSK-A63	4601743
25	62.5	110	56.5	84	M20	M18 x2	Form "AD"	2.50	WSLH-E/25-110/HSK-A63 **	4601744
32	72	110	60.5	84	M20	M20 x2	Form "AD"	2.85	WSLH-E/32-110/HSK-A63 **	4601745

**HSK-A100**

d (mm)	D (mm)	A (mm)	L1 (mm)	L3 (mm)	G	g	Kühlmittelzufuhr Coolant supply	N/W (Kg)	Bezeichnung Designation	Ident No.
06	25	90	36.5	61	M5	M6	Form "AD"	2.35	WSLH-E/06-90/HSK-A100	4601636
08	28	90	36.5	61	M6	M8	Form "AD"	2.40	WSLH-E/08-90/HSK-A100	4601637
10	35	90	40.5	61	M8	M10	Form "AD"	2.60	WSLH-E/10-90/HSK-A100	4601638
12	42	100	45.5	71	M10	M12	Form "AD"	2.90	WSLH-E/12-100/HSK-A100	4601639
14	44	100	45.5	71	M10	M12	Form "AD"	3.00	WSLH-E/14-100/HSK-A100	4601640
16	48	100	48.5	71	M12	M14	Form "AD"	3.05	WSLH-E/16-100/HSK-A100	4601641
18	50	100	48.5	71	M12	M14	Form "AD"	3.15	WSLH-E/18-100/HSK-A100	4601642
20	52	110	50.5	81	M16	M16	Form "AD"	3.35	WSLH-E/20-110/HSK-A100	4601643
25	65	120	56.5	91	M20	M18 x2	Form "AD"	4.20	WSLH-E/25-120/HSK-A100 **	4601644
32	72	120	60.5	91	M20	M20 x2	Form "AD"	4.55	WSLH-E/32-120/HSK-A100 **	4601645
40	80	120	70.5	91	M20	M20 x2	Form "AD"	4.90	WSLH-E/40-120/HSK-A100 **	4601646

Ersatzteile und Zubehör / Spare Parts & Accessories:



Pg.E2



Pg.D21

- Bohrungstoleranz H4
- Kühlmitrohr bitte separat bestellen (Siehe Seite D21)
- Stirnseitige Nut als Erkennungsmerkmal (im Unterschied zu Weldon)
- Im Lieferumfang enthalten: Spannschraube und Verstelleerschraube
- \*\* 2 Spannschrauben für ID Größe = 25 / 32 / 40

- Bore tolerance H4
- Please order coolant tube separately (Refer page D21)
- Groove on face for easy identification (to distinguish from Weldon)
- Delivery includes : Locking screw & adjusting screw
- \*\* 2 locking screws for ID size = 25 / 32 / 40

# Hochleistungsfräserspannfutter

## Hi-Power Milling Chuck

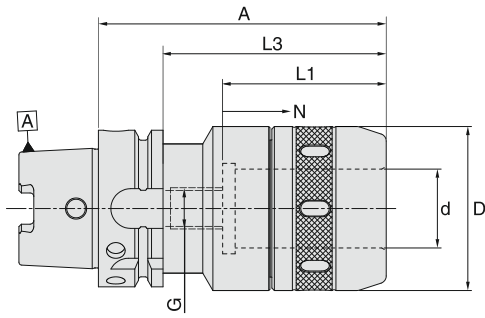

HSK-A63										
d (mm)	D (mm)	A (mm)	L1 (mm)	L3 (mm)	G	N	N/W (Kg)	Kühlmittelzufuhr Coolant supply	Bezeichnung Designation	Ident No.
20	52	90	60	68	M8x1	-	1.75	Form "AD"	WHPMC/20-90/HSK-A63	5056123
25	58	105	70	83	M8x1	5	2.05	Form "AD"	WHPMC/25-105/HSK-A63	5056125
32	66	135	75	113	M16x1	15	2.90	Form "AD"	WHPMC/32-135/HSK-A63	5056126

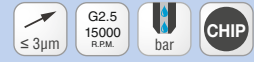

HSK-A100										
d (mm)	D (mm)	A (mm)	L1 (mm)	L3 (mm)	G	N	N/W (Kg)	Kühlmittelzufuhr Coolant supply	Bezeichnung Designation	Ident No.
20	52	100	60	71	M12x1	8	3.15	Form "AD"	WHPMC/20-100/HSK-A100	5058646
25	58	115	70	86	M8x1	8	3.70	Form "AD"	WHPMC/25-115/HSK-A100	5056129
32	66	135	75	106	M16x1	15	4.30	Form "AD"	WHPMC/32-135/HSK-A100	5056132

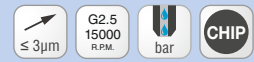

Ersatzteile und Zubehör / Spare Parts & Accessories: Pg.D12 Pg.D12 Pg.D21

- Kühlmittelrohr bitte separat bestellen (Siehe Seite D21)
- Please order coolant tube separately (Refer page D21)

Technische Details siehe Seite F4-F5 / For technical details refer page F4 - F5

# Schlanke Hochleistungsfräserspannfutter

## Slim Hi-Power Milling Chuck

BT MAS 403  
ISO7388-2

SK DIN 69871  
ISO7388-1

HSK DIN 69893

Zubehör  
Accessories

Ersatzteile  
Spare Parts

Technische Spezifikationen  
Technical Details

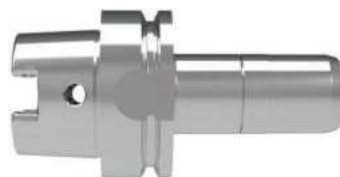
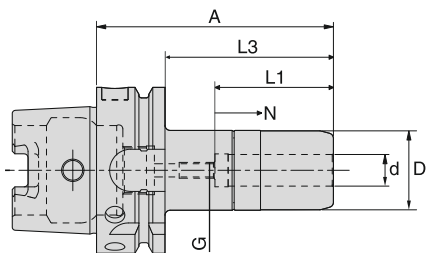

HSK-A50										
d (mm)	D (mm)	A (mm)	L1 (mm)	L3 (mm)	G	N	Kühlmittelzufuhr Coolant supply	N/W (Kg)	Bezeichnung Designation	Ident No.
6	25	100	36	74	-	8	Form "AD"	1.20	WHPMC/S06-100/HSK-A50	5105339
8	25	100	36	74	M6	8	Form "AD"	1.20	WHPMC/S08-100/HSK-A50	5105340
10	30	100	42	74	M8x1	8	Form "AD"	1.20	WHPMC/S10-100/HSK-A50	5105341



HSK-A63										
d (mm)	D (mm)	A (mm)	L1 (mm)	L3 (mm)	G	N	Kühlmittelzufuhr Coolant supply	N/W (Kg)	Bezeichnung Designation	Ident No.
6	25	100	36	74	M5	8	Form "AD"	1.40	WHPMC/S06-100/HSK-A63	5105342
8	25	100	36	74	M6	8	Form "AD"	1.40	WHPMC/S08-100/HSK-A63	5105343
10	30	100	42	74	M8x1	8	Form "AD"	1.40	WHPMC/S10-100/HSK-A63	5105345
12	30	90	45	64	M8	8	Form "AD"	1.30	WHPMC/S12-90/HSK-A63	5097495
12	30	135	45	109	M8	8	Form "AD"	1.60	WHPMC/S12-135/HSK-A63	5097496
16	38	90	50	64	M8	10	Form "AD"	1.30	WHPMC/S16-90/HSK-A63	5097497
16	38	135	50	109	M8	10	Form "AD"	2.10	WHPMC/S16-135/HSK-A63	5097498
20	44	90	55	64	-	-	Form "AD"	1.65	WHPMC/S20-90/HSK-A63	5097499
20	44	150	55	124	M12x1	10	Form "AD"	2.55	WHPMC/S20-150/HSK-A63	5097500



HSK-A100										
d (mm)	D (mm)	A (mm)	L1 (mm)	L3 (mm)	G	N	Kühlmittelzufuhr Coolant supply	N/W (Kg)	Bezeichnung Designation	Ident No.
12	30	100	45	71	-	8	Form "AD"	3.10	WHPMC/S12-100/HSK-A100	5097501
12	30	135	45	106	M8	8	Form "AD"	3.30	WHPMC/S12-135/HSK-A100	5097503
16	38	100	50	71	M8	10	Form "AD"	3.40	WHPMC/S16-100/HSK-A100	5097504
16	38	135	50	106	M8	10	Form "AD"	3.80	WHPMC/S16-135/HSK-A100	5097505
20	44	100	55	71	-	-	Form "AD"	3.50	WHPMC/S20-100/HSK-A100	5097506
20	44	150	55	121	M12x1	10	Form "AD"	4.20	WHPMC/S20-150/HSK-A100	5097507

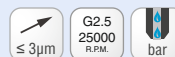

Ersatzteile und Zubehör / Spare Parts & Accessories:	Pg.D13	Pg.D13	Pg.D21
--	--------	--------	--------

Technische Details siehe Seite F4-F5 / For technical details refer page F4-F5



## Mini-Spannzangenhalter Mini Collet Holder

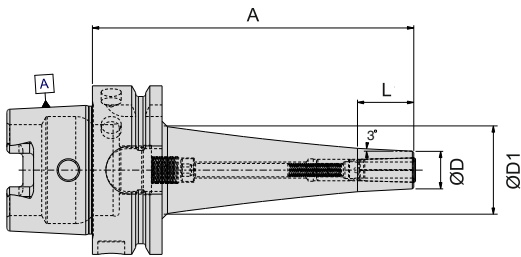

HSK-A50									
Spannzange Collet Type	Bereich Range	A (mm)	L (mm)	D (mm)	D1 (mm)	Kühlmittelezufuhr Coolant supply	N/W (Kg)	Bezeichnung Designation	Ident No.
MC14	3-6	90	21.0	14	29	-	0,60	WMCH/D14-90/HSK-A50	66658712M

HSK-A63									
Spannzange Collet Type	Bereich Range	A (mm)	L (mm)	D (mm)	D1 (mm)	Kühlmittelezufuhr Coolant supply	N/W (Kg)	Bezeichnung Designation	Ident No.
MC14	3-6	90	21.0	14	29	-	0,80	WMCH/D14-90/HSK-A63	66658277M
MC14	3-6	120	21.0	14	33	-	1,00	WMCH/D14-120/HSK-A63	66658714M
MC14	3-6	150	21.0	14	40	-	1,10	WMCH/D14-150/HSK-A63	66658715M
MC21	3-6	120	31.5	21	43	-	1,20	WMCH/D21-120/HSK-A63	66658732M
MC21	3-6	150	31.5	21	47	-	1,50	WMCH/D21-150/HSK-A63	66658733M

Ersatzteile und Zubehör / Spare Parts & Accessories: Pg.D16 Pg.D16 Pg.D16 Pg.D21

Für HSK-E typ siehe Seite C20 / HSK-E variants are also available, please refer page no.C20

Für Technische Details siehe Seite F8 / For technical details please refer page F8 and also the instruction manual provided in the packing box.

## Hydrodehnspannfutter (kurze & verstärkt) Hydraulic Expansion Chucks (Short & Rigid)

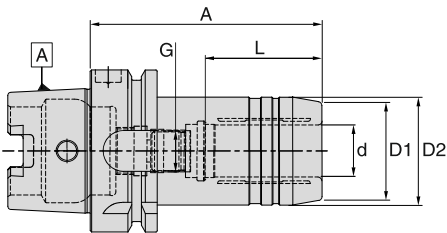

HSK-A63									
d (mm)	A	D1 (mm)	D2 (mm)	L	G	N/W (Kg)	Kühlmittelezufuhr Coolant supply	Bezeichnung Designation	Ident No.
12	80	32	42.0	41	M8X1.0	1.20	Form "AD"	WHEC-P/12-80/HSK-A63	5159324
20	80	38	52.5	48	M8X1.0	1.30	Form "AD"	WHEC-P/20-80/HSK-A63	5159325

HSK-A100									
d (mm)	A	D1 (mm)	D2 (mm)	L	G	N/W (Kg)	Kühlmittelezufuhr Coolant supply	Bezeichnung Designation	Ident No.
20	90	38.0	52.5	48	M8X1.0	2.80	Form "AD"	WHEC-P/20-90/HSK-A100	5159326
32	100	58.5	72.0	57	M8X1.0	3.70	Form "AD"	WHEC-P/32-100/HSK-A100	5159327

Ersatzteile und Zubehör / Spare Parts & Accessories: Pg.D14 Pg.D21

• Kühlmittelrohr bitte separat bestellen (Siehe Seite D21)

• Please order coolant tube separately (Refer page D21)

# Hydrodehnspannfutter

## Hydraulic Expansion Chucks

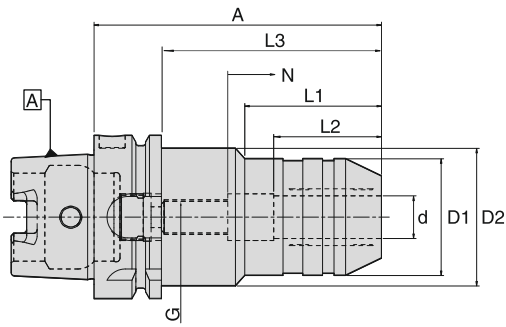

HSK-A50														
d (mm)	A (mm)	D1 (mm)	D2 (mm)	L1 (mm)	L2 (mm)	L3 (mm)	G	N	N/W (Kg)	Kühlmittelezufuhr Coolant supply	Bezeichnung Designation	Ident No.		
06	70	26	40	28	27	44	M5X0.8	10	0.65	Form "AD"	WHEC/06-70/HSK-A50	5161198		
08	70	28	40	28	27	44	M6X1.0	10	0.70	Form "AD"	WHEC/08-70/HSK-A50	5161199		
10	75	30	40	34	32	54	M8X1.0	10	0.70	Form "AD"	WHEC/10-75/HSK-A50	5161200		
12	85	32	40	44	37	59	M10X1.0	10	0.75	Form "AD"	WHEC/12-85/HSK-A50	5161202		
14	85	34	40	43	37	59	M10X1.0	10	0.75	Form "AD"	WHEC/14-85/HSK-A50	5161204		
16	90	38	53	30	42	64	M12X1.0	10	0.90	Form "AD"	WHEC/16-90/HSK-A50	5161206		
18	90	40	57	30	42	64	M12X1.0	10	0.90	Form "AD"	WHEC/18-90/HSK-A50	5161207		
20	90	42	60	29	42	64	M16X1.0	10	1.10	Form "AD"	WHEC/20-90/HSK-A50	5161208		

HSK-A63														
d (mm)	A (mm)	D1 (mm)	D2 (mm)	L1 (mm)	L2 (mm)	L3 (mm)	G	N	N/W (Kg)	Kühlmittelezufuhr Coolant supply	Bezeichnung Designation	Ident No.		
06	70	26	50	24	27	44	M5X0.8	10	1.08	Form "AD"	WHEC/06-70/HSK-A63	5056135		
08	70	28	50	25	27	44	M6X1.0	10	1.09	Form "AD"	WHEC/08-70/HSK-A63	5056136		
10	80	30	50	35	32	54	M8X1.0	10	1.00	Form "AD"	WHEC/10-80/HSK-A63	5056137		
12	85	32	50	40	37	59	M10X1.0	10	1.03	Form "AD"	WHEC/12-85/HSK-A63	5056138		
14	85	34	50	40	37	59	M10X1.0	10	1.05	Form "AD"	WHEC/14-85/HSK-A63	5056139		
16	90	38	50	46	42	64	M12X1.0	10	1.15	Form "AD"	WHEC/16-90/HSK-A63	5056140		
18	90	40	50	47	42	64	M12X1.0	10	1.15	Form "AD"	WHEC/18-90/HSK-A63	5056141		
20	90	42	50	48	42	64	M16X1.0	10	1.20	Form "AD"	WHEC/20-90/HSK-A63	5056143		
25	120	57	63	59	48	94	M16X1.0	10	2.20	Form "AD"	WHEC/25-120/HSK-A63	5056146		
32	125	64	75	63	55	99	M16X1.0	10	2.40	Form "AD"	WHEC/32-125/HSK-A63	5056147		

HSK-A100													
d (mm)	D1 (mm)	D2 (mm)	A (mm)	L1 (mm)	L2 (mm)	L3 (mm)	G	N	N/W (Kg)	Kühlmittelezufuhr Coolant supply	Bezeichnung Designation	Ident No.	
06	26	50	75	26	27	46	M5X0.8	10	3.20	Form "AD"	WHEC/06-75/HSK-A100	5056148	
08	28	50	75	26	27	46	M6X1.0	10	3.20	Form "AD"	WHEC/08-75/HSK-A100	5056149	
10	30	50	90	42	32	61	M8X1.0	10	3.40	Form "AD"	WHEC/10-90/HSK-A100	5056153	
12	32	50	95	47	37	66	M10X1.0	10	3.40	Form "AD"	WHEC/12-95/HSK-A100	5056154	
14	34	50	95	47	37	66	M10X1.0	10	3.40	Form "AD"	WHEC/14-95/HSK-A100	5056155	
16	38	50	100	53	42	71	M12X1.0	10	3.50	Form "AD"	WHEC/16-100/HSK-A100	5056156	
18	40	50	100	53	42	71	M12X1.0	10	3.60	Form "AD"	WHEC/18-100/HSK-A100	5056157	
20	42	50	105	59	42	76	M16X1.0	10	4.00	Form "AD"	WHEC/20-105/HSK-A100	5056158	
25	57	63	110	62	48	81	M16X1.0	10	4.20	Form "AD"	WHEC/25-110/HSK-A100	5056159	
32	64	75	110	62	55	81	M16X1.0	10	4.30	Form "AD"	WHEC/32-110/HSK-A100	5056160	

Ersatzteile und Zubehör / Spare Parts & Accessories: Pg.D14 Pg.D21

• Kühlmittelrohr bitte separat bestellen (Siehe Seite D21) • Please order coolant tube separately (Refer page D21)

# Präzisions-Schnellspanbohrfutter

## Precision Keyless Drill Chuck

BT MAS 403  
ISO7388-2

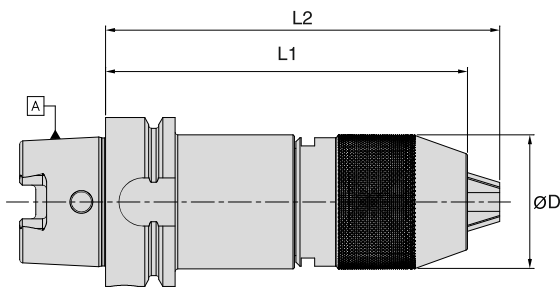

HSK-A63							
D (mm)	L1 (mm)	L2 (mm)	Bereich Range	Kühlmittelzufuhr Coolant supply	N/W (Kg)	Bezeichnung Designation	Ident No.
50	135	147	1-13	-	2.06	WDC/1-13-135/HSK-A63	66657340M



HSK-A100							
D (mm)	A (mm)	L (mm)	Bereich Range	Kühlmittelzufuhr Coolant supply	N/W (Kg)	Bezeichnung Designation	Ident No.
50	140	152	1-13	-	3.44	WDC/1-13-140/HSK-A100	66657341M

- kompakte Bauweise
- hohe Rundlaufgenauigkeit
- sichere Spannung durch selbsthemmendes Getriebe
- für Rechts- und Linkslauf geeignet
- compact design
- high run-out accuracy
- secure clamping due to self-locking gear
- suitable for clockwise and counter-clockwise operations

SK DIN 69871  
ISO7388-1

HSK DIN 69893

# Zwischenhülsen für Morse-Kegel mit Anzugsgewinde DIN 6364 / 228A

## Adaptor sleeves for Morse taper with thread DIN 6364 / 228A

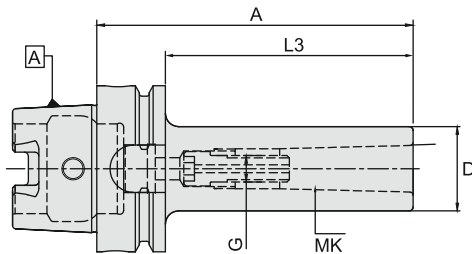

HSK-A63								
MK	D (mm)	A (mm)	L3 (mm)	G	Kühlmittelzufuhr Coolant supply	N/W (Kg)	Bezeichnung Designation	Ident No.
1	25	100	74	M6	-	1.00	WMTB/MT1-100/HSK-A63	4601750
2	32	120	94	M10	-	1.20	WMTB/MT2-120/HSK-A63	4601751
3	40	140	114	M12	-	1.60	WMTB/MT3-140/HSK-A63	4601752
4	48	160	134	M16	-	2.10	WMTB/MT4-160/HSK-A63	4601753

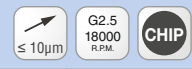

HSK-A100								
MK	D (mm)	A (mm)	L3 (mm)	G	Kühlmittelzufuhr Coolant supply	N/W (Kg)	Bezeichnung Designation	Ident No.
1	25	110	81	M6	-	2.45	WMTB/MT1-110/HSK-A100	4601652
2	32	120	91	M10	-	2.60	WMTB/MT2-120/HSK-A100	4601653
3	40	150	121	M12	-	3.00	WMTB/MT3-150/HSK-A100	4601654
4	48	170	141	M16	-	3.55	WMTB/MT4-170/HSK-A100	4601655
5	63	200	171	M20	-	4.90	WMTB/MT5-200/HSK-A100	4601656

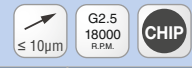

Ersatzteile und Zubehör / Spare Parts & Accessories: Pg.E5 Pg.E5 Pg.D21

- Im Lieferumfang enthalten: eingebaute Innensechskantschraube
- Kühlmittelrohr bitte separat bestellen (Siehe Seite D20)
- Delivery includes : built-in draw screw
- Please order coolant tube separately (Refer page D20)

Zubehör  
Accessories

Ersatzteile  
Spare Parts

Technische Spezifikationen  
Technical Details

Zwischenhülsen für Morse-Kegel mit Austreibblappen DIN 6383  
 Adaptor sleeves for Morse taper with tang to DIN 6383

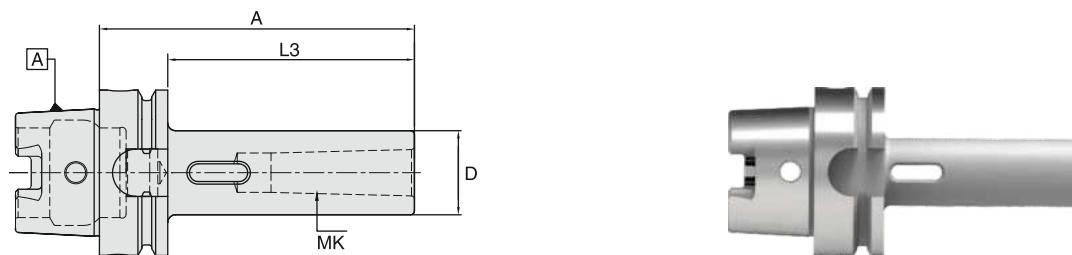

HSK-A63							
MK	D (mm)	A (mm)	L3 (mm)	Kühlmittelzufuhr Coolant supply	N/W (Kg)	Bezeichnung Designation	Ident No.
1	25	100	74	-	1.00	WMTA/MT1-100/HSK-A63	4601746
2	32	120	94	-	1.20	WMTA/MT2-120/HSK-A63	4601747
3	40	140	114	-	1.60	WMTA/MT3-140/HSK-A63	4601748
4	48	160	134	-	2.10	WMTA/MT4-160/HSK-A63	4601749



HSK-A100							
MK	D (mm)	A (mm)	L3 (mm)	Kühlmittelzufuhr Coolant supply	N/W (Kg)	Bezeichnung Designation	Ident No.
1	25	110	81	-	2.35	WMTA/MT1-110/HSK-A100	4601647
2	32	120	91	-	2.55	WMTA/MT2-120/HSK-A100	4601648
3	40	150	121	-	3.00	WMTA/MT3-150/HSK-A100	4601649
4	48	170	141	-	3.50	WMTA/MT4-170/HSK-A100	4601650
5	63	200	171	-	4.65	WMTA/MT5-200/HSK-A100	4601651



• Kühlmittelrohr bitte separat bestellen (Siehe Seite D21)      • Please order coolant tube separately (Refer page D21)

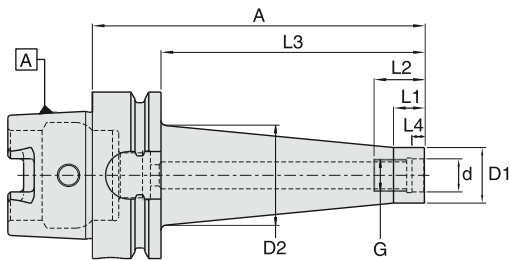

HSK-A63



G	d (mm)	D1 (mm)	D2 (mm)	A (mm)	L1 (mm)	L2 (mm)	L3 (mm)	L4 (mm)	Kühlmittelzufuhr Coolant supply	N/W (Kg)	Bezeichnung Designation	Ident No.
M8	8.5	13.8	15	51	12	19	25	6.5	Form "AD"	0.75	WTA/M8-51/HSK-A63	5055783
M8	8.5	13.8	23	76	12	19	50	6.5	Form "AD"	0.85	WTA/M8-76/HSK-A63	5055784
M8	8.5	13.8	25	101	12	19	75	6.5	Form "AD"	0.90	WTA/M8-101/HSK-A63	5055785
M10	10.5	18.0	23	51	12	19	25	6.5	Form "AD"	0.75	WTA/M10-51/HSK-A63	5055786
M10	10.5	18.0	25	76	12	19	50	6.5	Form "AD"	0.85	WTA/M10-76/HSK-A63	5055787
M10	10.5	18.0	35	126	12	19	100	6.5	Form "AD"	1.10	WTA/M10-126/HSK-A63	5055788
M10	10.5	18.0	45	176	12	19	150	6.5	Form "AD"	1.50	WTA/M10-176/HSK-A63	5055789
M12	12.5	21.0	24	51	12	25	25	7.0	Form "AD"	0.75	WTA/M12-51/HSK-A63	5055790
M12	12.5	21.0	30	76	12	25	50	7.0	Form "AD"	0.90	WTA/M12-76/HSK-A63	5055791
M12	12.5	21.0	38	126	12	25	100	7.0	Form "AD"	1.20	WTA/M12-126/HSK-A63	5055792
M12	12.5	21.0	45	176	12	25	150	7.0	Form "AD"	1.70	WTA/M12-176/HSK-A63	5055793
M16	17.0	29.0	29	51	12	31	25	8.0	Form "AD"	0.85	WTA/M16-51/HSK-A63	5055794
M16	17.0	29.0	34	76	12	31	50	8.0	Form "AD"	0.95	WTA/M16-76/HSK-A63	5055795
M16	17.0	29.0	40	126	12	31	100	8.0	Form "AD"	1.40	WTA/M16-126/HSK-A63	5055796
M16	17.0	29.0	48	176	12	31	150	8.0	Form "AD"	1.95	WTA/M16-176/HSK-A63	5055797

HSK-A100

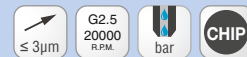

G	d (mm)	D1 (mm)	D2 (mm)	A (mm)	L1 (mm)	L2 (mm)	L3 (mm)	L4 (mm)	Kühlmittelzufuhr Coolant supply	N/W (Kg)	Bezeichnung Designation	Ident No.
M10	10.5	18.0	25	79	12	19	50	6.5	Form "AD"	2.20	WTA/M10-79/HSK-A100	5055798
M10	10.5	18.0	35	129	12	19	100	6.5	Form "AD"	2.50	WTA/M10-129/HSK-A100	5055799
M10	10.5	18.0	45	179	12	19	150	6.5	Form "AD"	3.00	WTA/M10-179/HSK-A100	5055800
M12	12.5	21.0	30	79	12	25	50	7.0	Form "AD"	2.20	WTA/M12-79/HSK-A100	5055801
M12	12.5	21.0	38	129	12	25	100	7.0	Form "AD"	2.55	WTA/M12-129/HSK-A100	5055802
M12	12.5	21.0	45	179	12	25	150	7.0	Form "AD"	3.05	WTA/M12-179/HSK-A100	5055803
M16	17.0	29.0	34	79	12	31	50	8.0	Form "AD"	2.30	WTA/M16-79/HSK-A100	5055804
M16	17.0	29.0	40	129	12	31	100	8.0	Form "AD"	2.75	WTA/M16-129/HSK-A100	5055805
M16	17.0	29.0	48	179	12	31	150	8.0	Form "AD"	3.30	WTA/M16-179/HSK-A100	5055806

Ersatzteile und Zubehör / Spare Parts & Accessories: Pg.D21

- Kühlmittelrohr bitte separat bestellen (Siehe Seite D21)
- Siehe Seite D14 für Einschraubfräser Verlängerung & Reduzierung
- Please order coolant tube separately (Refer page D21)
- Refer page D14 for Threaded Arbor extensions & reductions.

# Aufsteckfräserdorne DIN 6358 mit Längs- und Quernut (Kombi) Shell mill holder with DIN 6358 (Combi)

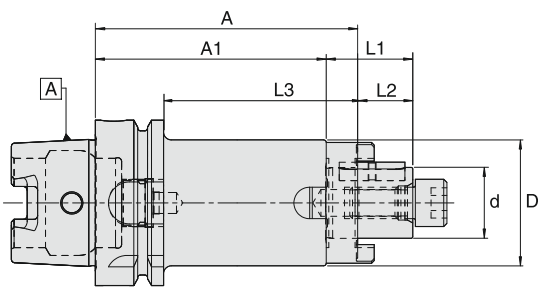

HSK-A63										
d (mm)	D (mm)	A (mm)	A1 (mm)	L1 (mm)	L2 (mm)	L3 (mm)	Kühlmittelezufuhr Coolant supply	N/W (Kg)	Bezeichnung Designation	Ident No.
16	32	60	50	27	17	34	-	1.00	WFSH/16-60/HSK-A63	4601754
22	40	60	48	31	19	34	-	1.20	WFSH/22-60/HSK-A63	4601756
27	48	60	48	33	21	34	-	1.50	WFSH/27-60/HSK-A63	4601758
32	53	60	46	38	24	34	-	1.55	WFSH/32-60/HSK-A63	4601760
40	70	70	56	41	27	44	-	2.10	WFSH/40-70/HSK-A63 **	4601762
16	32	100	90	27	17	74	-	1.30	WFSH/16-100/HSK-A63	4601755
22	40	100	88	31	19	74	-	1.50	WFSH/22-100/HSK-A63	4601757
27	48	100	88	33	21	74	-	2.00	WFSH/27-100/HSK-A63	4601759
32	58	100	86	38	24	74	-	2.60	WFSH/32-100/HSK-A63	4601761
40	70	100	86	41	27	74	-	3.10	WFSH/40-100/HSK-A63 **	5055763



HSK-A63										
d (mm)	D (mm)	A (mm)	A1 (mm)	L1 (mm)	L2 (mm)	L3 (mm)	Kühlmittelezufuhr Coolant supply	N/W (Kg)	Bezeichnung Designation	Ident No.
16	32	160	150	27	17	134	-	1.90	WFSH/16-160/HSK-A63 ❖	5055764
22	40	160	148	31	19	134	-	2.50	WFSH/22-160/HSK-A63 ❖	5055765
27	48	160	148	33	21	134	-	2.90	WFSH/27-160/HSK-A63	5055766
32	58	160	146	38	24	134	-	3.60	WFSH/32-160/HSK-A63	5055767
40	70	160	146	41	27	134	-	4.80	WFSH/40-160/HSK-A63 **	5055772



HSK-A100										
d (mm)	D (mm)	A (mm)	A1 (mm)	L1 (mm)	L2 (mm)	L3 (mm)	Kühlmittelezufuhr Coolant supply	N/W (Kg)	Bezeichnung Designation	Ident No.
16	32	60	50	27	17	31	-	2.30	WFSH/16-60/HSK-A100	5055773
22	40	60	48	31	19	31	-	2.55	WFSH/22-60/HSK-A100	4601658
27	48	60	48	33	21	31	-	2.70	WFSH/27-60/HSK-A100	4601659
32	58	60	46	38	24	31	-	3.00	WFSH/32-60/HSK-A100	4601660
40	70	70	56	41	27	41	-	3.60	WFSH/40-70/HSK-A100 **	4601661



Ersatzteile und Zubehör / Spare Parts & Accessories: Pg.E3 Pg.E4 Pg.E3 Pg.D21 Pg.D21

- Im Lieferumfang enthalten: Passfeder, Mitnehmerring, Fräseranzugsschraube und Spannschrauben (DIN 912)
- Spannschrauben (DIN 6367) bitte separat bestellen (Siehe Seite E3)
- \*\* Im Lieferumfang enthalten: Spannschrauben (DIN 6367)
- Kühlmittelrohr bitte separat bestellen (Siehe Seite D21)
- ❖ Für WFSH/16-160/HSK-A63, D2=49.2mm & L4=77mm
- For WFSH/22-160/HSK-A63, D2=53.3mm & L4=81mm

- Delivery includes : Parallel key, drive ring, clamping screw and locking screw (DIN 912)
- Please order locking screw (DIN 6367) separately (refer page E3)
- \*\* Delivery includes: Locking screw (DIN 6367)
- Please order coolant tube separately (Refer page D21)
- ❖ Note: For WFSH/16-160/HSK-A63, D2=49.2mm & L4=77mm
- For WFSH/22-160/HSK-A63, D2=53.3mm & L4=81mm

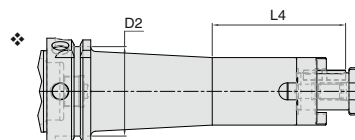

# Aufnahmedorn mit Innenzentrierung DIN 6357 und vergrößertem Bunddurchmesser

## Shell mill holder DIN 6357 for cutters with drive key

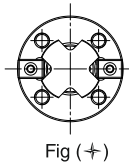
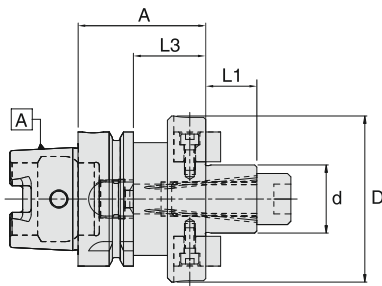

### HSK-A50

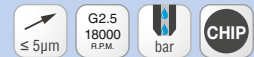

d (mm)	D (mm)	A (mm)	L1 (mm)	L3 (mm)	Kühlmittelezufuhr Coolant supply	N/W (Kg)	Bezeichnung Designation	Ident No.
16	38	50	17	24	Form "AD"	0.75	WSMH/16-50/HSK-A50	5103448
22	48	60	19	34	Form "AD"	1.05	WSMH/22-60/HSK-A50	5103450
27	58	60	21	34	Form "AD"	1.30	WSMH/27-60/HSK-A50	5103452
32	78	60	24	34	Form "AD"	1.60	WSMH/32-60/HSK-A50	5103454
16	38	100	17	74	Form "AD"	1.25	WSMH/16-100/HSK-A50	5103457
22	48	100	19	74	Form "AD"	1.60	WSMH/22-100/HSK-A50	5103459
27	58	100	21	74	Form "AD"	2.00	WSMH/27-100/HSK-A50	5103461
32	78	100	24	74	Form "AD"	2.40	WSMH/32-100/HSK-A50	5103462

### HSK-A63

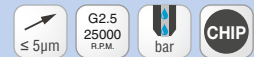

d (mm)	D (mm)	A (mm)	L1 (mm)	L3 (mm)	Kühlmittelezufuhr Coolant supply	N/W (Kg)	Bezeichnung Designation	Ident No.
16	38	50	17	24	Form "AD"	1.05	WSMH/16-50/HSK-A63	4601763
22	48	50	19	24	Form "AD"	1.20	WSMH/22-50/HSK-A63	4601765
27	58	60	21	34	Form "AD"	1.60	WSMH/27-60/HSK-A63	4601767
32	78	60	24	34	Form "AD"	1.90	WSMH/32-60/HSK-A63	4601769
40	88	60	27	34	Form "AD"	2.40	WSMH/40-60/HSK-A63+	4601771
16	38	100	17	74	Form "AD"	1.50	WSMH/16-100/HSK-A63	4601764
22	48	100	19	74	Form "AD"	1.90	WSMH/22-100/HSK-A63	4601766
27	58	100	21	74	Form "AD"	2.40	WSMH/27-100/HSK-A63	4601768
32	78	100	24	74	Form "AD"	3.30	WSMH/32-100/HSK-A63	4601770
40	88	100	27	74	Form "AD"	4.00	WSMH/40-100/HSK-A63+	4601772
16	38	160	17	134	Form "AD"	1.82	WSMH/16-160/HSK-A63	5152830
22	48	160	19	134	Form "AD"	2.56	WSMH/22-160/HSK-A63	5152831
27	58	160	21	134	Form "AD"	3.42	WSMH/27-160/HSK-A63	5152832
32	78	160	24	134	Form "AD"	5.21	WSMH/32-160/HSK-A63	5152833
40	88	160	27	134	Form "AD"	6.73	WSMH/40-160/HSK-A63+	5152834

#### Ersatzteile und Zubehör / Spare Parts & Accessories:



- Kühlbohrung an der Stirnseite Standard bei allen Grundhaltern  
 † ID = Ø 40, D = Ø 60 Mit 4 zusätzlichen Gewindebohrungen nach DIN 2079  
 and Im Lieferumfang enthalten: Spannschrauben (DIN 6367)
- Kühlmittelrohr bitte separat bestellen (Siehe Seite D21)
- Im Lieferumfang enthalten: Mitnehmersteine und  
 Innensechskantschraube (DIN 912)
- Spannschrauben (DIN6367) bitte separat bestellen (Siehe Seite E3)

- Coolant bore on the pilot face (holder with Form"AD") as standard  
 for all holders  
 † d = Ø 40, Ø 60 With additional 4 screw holes to DIN 2079 and  
 locking screw (DIN 6367) for Ø 40
- Please order coolant tube separately (Refer page D21)
- Delivery includes: Drive keys and socket head screw to DIN 912
- Please order locking screw (DIN6367) separately (refer page E3)

Aufnahmedorn mit Innenzentrierung DIN 6357 und vergrößertem Bunddurchmesser  
 Shell mill holder DIN 6357 for cutters with drive key

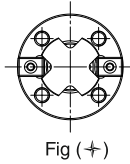
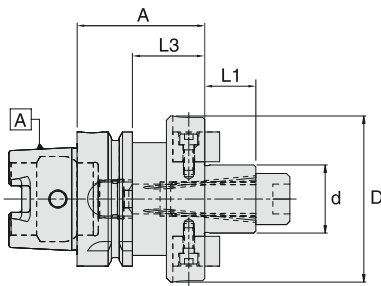

HSK-A100								
d (mm)	D (mm)	A (mm)	L1 (mm)	L3 (mm)	Kühlmittelezufuhr Coolant supply	N/W (Kg)	Bezeichnung Designation	Ident No.
16	38	50	17	21	Form "AD"	2.35	WSMH/16-50/HSK-A100	5056120
22	48	50	19	21	Form "AD"	2.50	WSMH/22-50/HSK-A100	4601663
27	58	50	21	21	Form "AD"	2.80	WSMH/27-50/HSK-A100	4601664
32	78	50	24	21	Form "AD"	3.10	WSMH/32-50/HSK-A100	4601665
40	88	60	27	31	Form "AD"	4.00	WSMH/40-60/HSK-A100+	4601666
60	129	70	40	41	Form "AD"	6.15	WSMH/60-70/HSK-A100+	5056122
16	38	100	17	71	Form "AD"	2.70	WSMH/16-100/HSK-A100	5152835
22	48	100	19	71	Form "AD"	3.06	WSMH/22-100/HSK-A100	5152836
27	58	100	21	71	Form "AD"	3.57	WSMH/27-100/HSK-A100	5152837
32	78	100	24	71	Form "AD"	4.74	WSMH/32-100/HSK-A100	5152838
40	88	100	27	71	Form "AD"	5.57	WSMH/40-100/HSK-A100+	5152839
16	38	160	17	131	Form "AD"	3.26	WSMH/16-160/HSK-A100	5152840
22	48	160	19	131	Form "AD"	3.88	WSMH/22-160/HSK-A100	5152841
27	58	160	21	131	Form "AD"	4.77	WSMH/27-160/HSK-A100	5152842
32	78	160	24	131	Form "AD"	6.94	WSMH/32-160/HSK-A100	5152843
40	88	160	27	131	Form "AD"	8.40	WSMH/40-160/HSK-A100+	5152844
22	48	200	19	171	Form "AD"	4.43	WSMH/22-200/HSK-A100	66658690M
27	58	200	21	221	Form "AD"	5.11	WSMH/27-200/HSK-A100	66658692M
22	48	250	19	171	Form "AD"	5.57	WSMH/22-250/HSK-A100	66658691M
27	58	250	21	221	Form "AD"	6.53	WSMH/27-250/HSK-A100	66658693M



Ersatzteile und Zubehör / Spare Parts & Accessories: Pg.D20 Pg.E3 Pg.E4 Pg.E4 Pg.D20

- Kühlbohrung an der Stirnseite Standard bei allen Grundhaltern  
 † ID = Ø 40, D = Ø 60 Mit 4 zusätzlichen Gewindebohrungen nach DIN 2079  
 and Im Lieferumfang enthalten: Spannschrauben (DIN 6367)
- Kühlmittelrohr bitte separat bestellen (Siehe Seite D21)
- Im Lieferumfang enthalten: Mitnehmersteine, Fräseranzugsschraube und Spannschrauben (DIN 912)
- Spannschrauben (DIN6367) bitte separat bestellen (Siehe Seite E3)
- Coolant bore on the pilot face (holder with Form"AD") as standard for all holders
- † d = Ø 40, Ø 60 With additional 4 screw holes to DIN 2079 and locking screw (DIN 6367) for Ø 40
- Please order coolant tube separately (Refer page D21)
- Delivery includes: Drive keys and socket head screw to DIN 912
- Please order locking screw (DIN6367) separately (refer page E3)



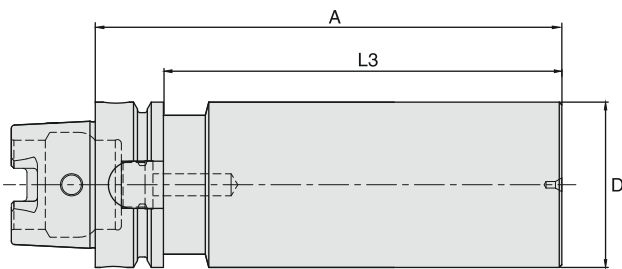

HSK-A32							35 ± 5 HRC	CHIP
D (mm)	A (mm)	L3 (mm)	Kühlmittelezufuhr Coolant supply	N/W (Kg)	Bezeichnung Designation	Ident No.		
35	150	130	-	1.10	WBBB/35-150/HSK-A32	9202418		

HSK-A40							35 ± 5 HRC	CHIP
D (mm)	A (mm)	L3 (mm)	Kühlmittelezufuhr Coolant supply	N/W (Kg)	Bezeichnung Designation	Ident No.		
40	150	130	-	1.60	WBBB/40-150/HSK-A40	9202419		
52	200	180	-	3.20	WBBB/52-200/HSK-A40	9202420		

HSK-A50							35 ± 5 HRC	CHIP
D (mm)	A (mm)	L3 (mm)	Kühlmittelezufuhr Coolant supply	N/W (Kg)	Bezeichnung Designation	Ident No.		
52	200	174	-	3.25	WBBB/52-200/HSK-A50	9202421		
63	200	174	-	4.50	WBBB/63-200/HSK-A50	9202422		

HSK-A63							35 ± 5 HRC	CHIP
D (mm)	A (mm)	L3 (mm)	Kühlmittelezufuhr Coolant supply	N/W (Kg)	Bezeichnung Designation	Ident No.		
63	150	124	-	3.70	WBBB/63-150/HSK-A63	5110222		
63	200	174	-	4.90	WBBB/63-200/HSK-A63	5112472		
80	250	224	-	9.15	WBBB/80-250/HSK-A63	5056271		
100	250	221	-	13.9	WBBB/100-250/HSK-A63	5110225		

HSK-A100							35 ± 5 HRC	CHIP
D (mm)	A (mm)	L3 (mm)	Kühlmittelezufuhr Coolant supply	N/W (Kg)	Bezeichnung Designation	Ident No.		
63.0	200	171	-	6.30	WBBB/63-200/HSK-A100	5056272		
80.0	250	221	-	10.85	WBBB/80-250/HSK-A100	5056273		
97.5	250	221	-	15.00	WBBB/97.5-250/HSK-A100	5056274		
100.0	250	221	-	15.50	WBBB/100-250/HSK-A100	5110228		

Ersatzteile und Zubehör / Spare Parts & Accessories: Pg.D21

- Im Lieferumfang enthalten: Bund gehärtet und geschliffen, Schaft weich
- Kühlmittelrohr bitte separat bestellen (Siehe Seite D21)

- Delivery includes : Shank and flange hardened, body left soft
- Please order coolant tube separately (Refer page D21)

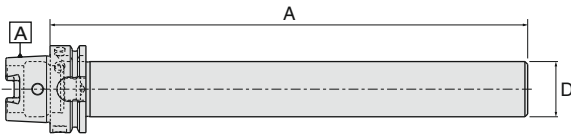

HSK-A50 <span style="float: right;">↗ ≤ 2µm</span>					
D (mm)	A (mm)	Kühlmittelezufuhr Coolant supply	N/W (Kg)	Bezeichnung Designation	Ident No.
40	300	-	4.2	WTMM/40-300/HSK-A50	5161209

HSK-A63 <span style="float: right;">↗ ≤ 2µm</span>					
D (mm)	A (mm)	Kühlmittelezufuhr Coolant supply	N/W (Kg)	Bezeichnung Designation	Ident No.
40	346	-	4.5	WTMM/40-346/HSK-A63	5056275

HSK-A100 <span style="float: right;">↗ ≤ 2µm</span>					
D (mm)	A (mm)	Kühlmittelezufuhr Coolant supply	N/W (Kg)	Bezeichnung Designation	Ident No.
50	349	-	6.4	WTMM/50-349/HSK-A100	5056276

• Kontrolldorne im Holzkasten geliefert      • Delivered in wooden box

DIN 69893 (HSK-E) Werkzeugaufnahmen  
DIN 69893 (HSK-E) Tool Holders



Spannzangenfutter ER Collet chuck ER	C24
Micro-Spannzangenhalter Micro collet holder	C25

DIN 69893 (HSK-F) Werkzeugaufnahmen  
DIN 69893 (HSK-F) Tool Holders

Spannzangenfutter ER Collet chuck ER	C25
---	-----

## Spannzangenfutter Typ ER für Spannzangen ISO 15488 (DIN 6499) (HSK-E)

Collet chuck type ER for collets to ISO 15488 (DIN 6499) (HSK-E)

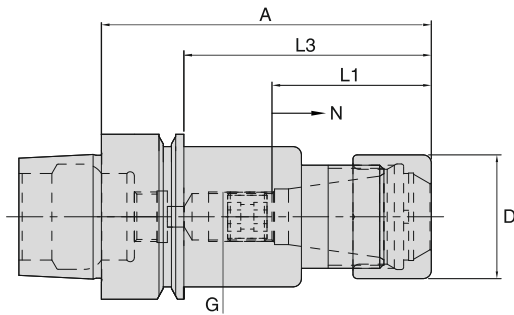

HSK-E32											≤ 3µm	G2.5 42000 R.P.M.	bar
Spannzange Collet Type	Bereich Range	D (mm)	A (mm)	L1 (mm)	L3 (mm)	N	G	Kühlmittelzufuhr Coolant supply	N/W (Kg)	Bezeichnung Designation	Ident No.		
ER16	1-10	27.1	65	33.5	45	8	M10	Form "AD"	0.30	WCCH/ERF16-65/HSK-E32	5100028		
ER20	1-13	33.0	70	38.0	50	8	M10	Form "AD"	0.40	WCCH/ERF20-70/HSK-E32	5100030		
ER25	2-16	40.0	70	41.0	50	8	M10	Form "AD"	0.40	WCCH/ERF25-70/HSK-E32	5100031		

HSK-E40											≤ 3µm	G2.5 42000 R.P.M.	bar
Spannzange Collet Type	Bereich Range	D (mm)	A (mm)	L1 (mm)	L3 (mm)	N	G	Kühlmittelzufuhr Coolant supply	N/W (Kg)	Bezeichnung Designation	Ident No.		
ER16	1-10	27.1	70	33.5	50	12	M10	Form "AD"	0.40	WCCH/ERF16-70/HSK-E40	5100032		
ER20	1-13	33.0	80	38.0	60	12	M12	Form "AD"	0.50	WCCH/ERF20-80/HSK-E40	5100033		
ER25	2-16	40.0	80	41.0	60	12	M16	Form "AD"	0.50	WCCH/ERF25-80/HSK-E40	5100034		
ER16	1-10	27.1	120	33.5	100	12	M10	Form "AD"	0.60	WCCH/ERF16-120/HSK-E40	5100035		
ER20	1-13	33.0	120	38.0	100	12	M12	Form "AD"	0.50	WCCH/ERF20-120/HSK-E40	5100036		
ER25	2-16	40.0	120	41.0	100	12	M16	Form "AD"	0.75	WCCH/ERF25-120/HSK-E40	5100037		

HSK-E50											≤ 3µm	G2.5 42000 R.P.M.	bar
Spannzange Collet Type	Bereich Range	D (mm)	A (mm)	L1 (mm)	L3 (mm)	N	G	Kühlmittelzufuhr Coolant supply	N/W (Kg)	Bezeichnung Designation	Ident No.		
ER16	1-10	27.1	80	33.5	54	12	M10	Form "AD"	0.90	WCCH/ERF16-80/HSK-E50	5100039		
ER20	1-13	33.0	95	38.0	69	12	M12	Form "AD"	1.00	WCCH/ERF20-95/HSK-E50	5100040		
ER25	2-16	40.0	95	41.0	69	12	M16	Form "AD"	1.05	WCCH/ERF25-95/HSK-E50	5100041		
ER32	2-20	48.0	100	47.0	74	12	M22X1.5	Form "AD"	0.85	WCCH/ERF32-100/HSK-E50	5100042		

Ersatzteile und Zubehör / Spare Parts & Accessories:



Pg.D2-D4



Pg.D9

- Kühlmittelrohr bitte separat bestellen (Siehe Seite D21)
- Im Lieferumfang enthalten: Spannmutter (gewuchtet)

- Please order coolant tube separately (Refer page D21)
- Delivery includes : Friction nut (balanced)

**Micro-Spannzangenhalter (HSK-E)**

Micro collet holder (HSK-E)

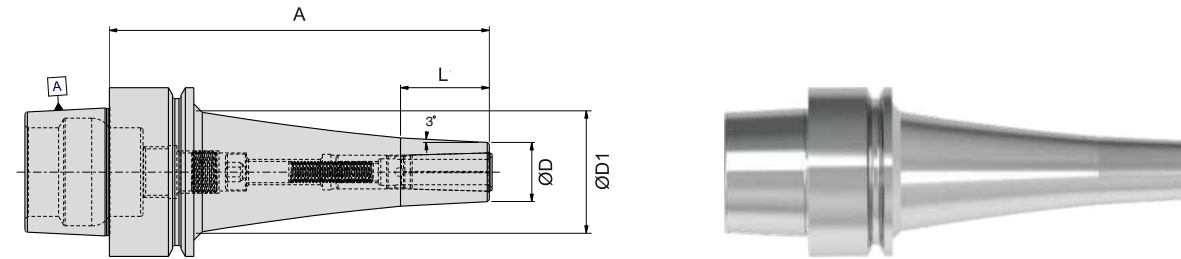

HSK-A50									
Spannzange Collet Type	Bereich Range	A (mm)	L (mm)	D (mm)	D1 (mm)	Kühlmittelzufuhr Coolant supply	N/W (Kg)	Bezeichnung Designation	Ident No.
MC14	3-6	70	21	14	22	-	0,30	WMCH/D14-70/HSK-E32	66658716M
MC14	3-6	90	21	14	23	-	0,35	WMCH/D14-90/HSK-E32	66658717M



HSK-A63									
Spannzange Collet Type	Bereich Range	A (mm)	L (mm)	D (mm)	D1 (mm)	Kühlmittelzufuhr Coolant supply	N/W (Kg)	Bezeichnung Designation	Ident No.
MC14	3-6	75	21	14	25	-	0,40	WMCH/D14-75/HSK-E40	66658718M
MC14	3-6	90	21	14	29	-	0,45	WMCH/D14-90/HSK-E40	66658719M



Ersatzteile und Zubehör / Spare Parts &amp; Accessories: Pg.D16 Pg.D16 Pg.D21

**Spannzangenfutter mit Hohlenschaftkegel HSK-F63**

Collet chuck with hollow taper shank HSK-F63

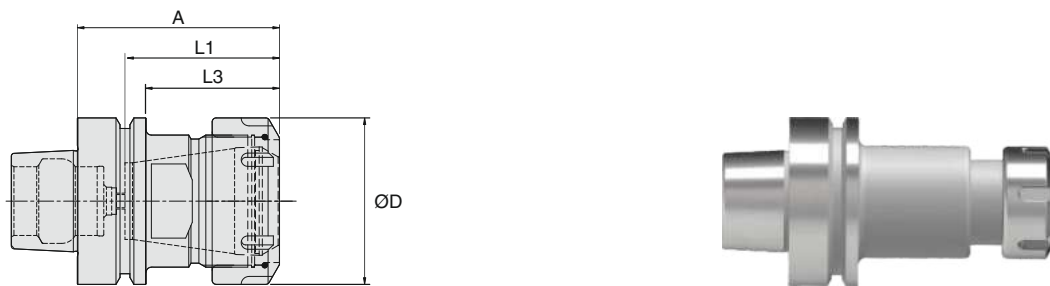

HSK-F63									
Spannzange Collet Type	Bereich Range	D (mm)	A (mm)	L1 (mm)	L3 (mm)	N/W (Kg)	Bezeichnung Designation		Ident No.
ER25	2-16	42	70.0	41.0	44.0	1.0	WCCH/ERB25-70/HSK-F63-DX		5100248
ER32	2-20	50	73.0	47.0	47.0	1.0	WCCH/ERB32-73/HSK-F63-DX		5100249
ER40	3-26	63	76.5	58.5	50.5	1.2	WCCH/ERB40-76.5/HSK-F63-DX		5100251



Ersatzteile und Zubehör / Spare Parts &amp; Accessories: Pg.D2-D4 Pg.D7 Pg.D4

- Im Lieferumfang enthalten : kugelgelagerte Spannmutter
- Hinweise: DX - für Rechtsgewinde
- Delivery includes: Clamping nut with ball bearing
- DX - for 'Right hand' thread

Spannzangen Collets	D2 - D4
Spannmuttern Clamping nuts	D4 - D5
Dichtscheiben Sealing discs	D6
Spannschlüssel, ER Zylinderschaft Wrench, ER Cylindrical shank	D7
WSCH - Super collet Spannzangen WSCH - Super Collet	D8 - D11
WHPMC - Zylindrische Spannzange WHPMC - Adjustable straight collet	D12 - D13
WHEC - Reduzierbuchsen WHEC - Reduction sleeves	D14
WTA - Verlängerung & Reduzierung WTA - Extensions & Reductions	D15
WMCH - Mini-Spannzangenhalter WMCH - Mini collet holder	D16
Drehmomentschlüssel Torque wrench	D17 - D18
Anzugsbolzen Pull studs	D19 - D20
Kühlmittelrohr Coolant tube	D21
Spannschlüssel DIN 6368 Spanner to DIN 6368	D21
Montagevorrichtung Assembly device	D22 - D23

Spannzangen DIN 6499 System ER  
Collets DIN 6499 ER-System

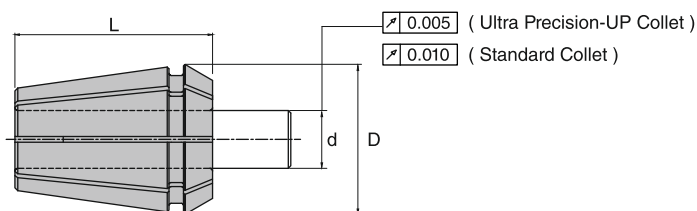

Spannbereich Clamping Range d (mm)	424E ER 11-... D=11.5, L=18mm ( 1.0-7.0 ) Ident No.	426E ER 16-... D=17, L=27mm ( 1.0-10.0 ) Ident No.	428E ER 20-... D=21, L=31mm ( 2.0-13.0 ) Ident No.	430E ER 25-... D=26, L=35mm ( 2.0-16.0 ) Ident No.	470E ER 32-... D=33, L=40mm ( 2.0-20.0 ) Ident No.	472E ER 40-... D=41, L=46mm ( 3.0-26.0 ) Ident No.
1.0-0.5(1/32")	5056179*	5057132				
..UP		6956076				
2.0-1.0(1/16")	5056181*	5057134	5057149	5056198	5056200	
..UP		6951390	6950718	6956077	6954804	
3.0-2.0	5056182*	5057135	5057151	5057171	5057226	5056211
..UP		6950577	6954121	6950639	6954216	
4.0-3.0(5/32")	5056184*	5057136	5057152	5057172	5057228	5057255
..UP		6951316	6954011	6951451	6954116	6954654
5.0-4.0(3/16")	5056187*	5057137	5057159	5057173	5057229	5057257
..UP		6944020	6953669	6951452	6954117	6954660
6.0-5.0(7/32")	5056189*	5057138	5057160	5057174	5057230	5057259
..UP		6927048	6944021	6950640	6952206	6952415
7.0-6.0	5056191*	5057141	5057161	5057175	5057232	5057260
..UP		6927050	6950721	6952697	6954217	6954661
8.0-7.0(5/16")		5057144	5057163	5057176	5057234	5057261
..UP		6927051	6927052	6951210	6952200	6954662
9.0-8.0(11/32")		5057145	5057164	5057178	5057235	5057263
..UP		6953019	6952604	6921604	6954118	6955191
10.0-9.0		5057146	5057166	5057179	5057237	5057264
..UP		6951332	6927053	6950641	6952201	6953442
11.0-10.0			5057168	5057181	5057238	5057265
..UP			6927055	6951404	6951867	
12.0-11.0(15/32")			5057169	5057182	5057239	5057266
..UP			6944022	6951209	6946688	6953443
13.0-12.0(1/2")			5057170	5057183	5057240	5057267
..UP			6954657	6951317	6952718	6955748
14.0-13.0				5057184	5057241	5057268
..UP				6951211	6946611	6955975
15.0-14.0				5057185	5057245	5057269
..UP				6921605	6954218	6954119
16.0-15.0(5/8")				5057186	5057247	5057270
..UP				6950642	6951212	6953444
17.0-16.0(21/32")					5057248	5057271
..UP					6954219	6955196
18.0-17.0					5057249	5057273
..UP					6951213	6946165
19.0-18.0					5057250	5057274
..UP					6954220	6954120
20.0-19.0(25/32")					5057251	5057275
..UP					6950710	6951764
21.0-20.0(13/16")						5057276
22.0-21.0						5057277
..UP						6952605
23.0-22.0						5057284
24.0-23.0(15/16")						5057285
25.0-24.0(31/32")						5057286
..UP						6951765
26.0-25.0						5057287
..UP						6955666
ER Collet Set	5083043	5064416	5083046	5064421	5064428	5064429
..UP		5104124	5104125	5104126	5104127	9173813

Bestellbeispiel: / How to order : Standard-Spannzange / Standard Collet: ER16-1.0 or 5057132 and UP Spannzangen / UP Collet: ESX 16-1.0-UP or 6956076  
\*0.5mm collapsibility for ER11 collets

Spannzangensystem ER mit Innenvierkant DIN 6499  
 Tap Collet ER-System with internal square DIN 6499

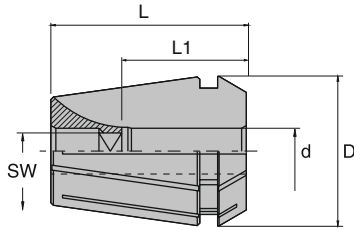

Schaft Shaft d (mm) Ø	Innenvierkant Square SW (mm)	L1 (mm)	426G ESX 16-... D=16.7mm L=27.5mm Ident No.	428G ESX 20-... D=21mm L=31mm Ident No.	430G ESX 25-... D=25.7mm L=34mm Ident No.	470G ESX 32-... D=33mm L=40mm Ident No.	472G ESX 40-... D=41mm L=46mm Ident No.
4.0	3.0	18	6954588				
4.5	3.4	18	6951393	6948389	6951218	6952585	
5.5	4.3	18	6954656	6949764	5073851	5069531	
6.0	4.9	18	6951392	6948390	6951544	6949997	
7.0	5.5	18	6947340	6949767	6951797	6950029	
8.0	6.2	18		6949202	6951214	6949769	6955396
9.0	7.0	18		6947338	6951216	6946965	6955397
10.0	8.0	22		6949111	6951215	6949998	9080012
11.0	9.0	22		6949177	6946167	6946104	6955398
12.0	9.0	22			6950343	6946106	9074741
14.0	11.0	25			6951559	6947337	9074742
16.0	12.0	25			6951399	6948391	9080073
18.0	14.5	25				6950206	6952207
20.0	16.0	28				6948392	6948903
22.0	18.0	28					6949124

Bestellbeispiel: / How to order :

ESX16-6.0x4.9 or 6951392



## Abgedichtete Spannzangen ER Sealed Collet ER - system for internal coolant

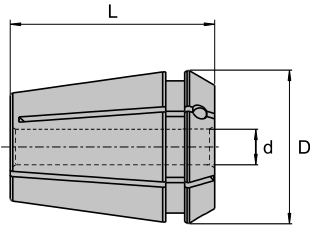

Schaft Shaft d (mm) Ø	ERC 16-... D=17mm L=27.5mm Ident No.	ERC 20-... D=21mm L=31.5mm Ident No.	ERC 25-... D=26mm L=34mm Ident No.	ERC 32-... D=33mm L=40mm Ident No.	ERC 40-... D=41mm L=46mm Ident No.
3.0	5161379	5161389	5161402	5161897	5162178
4.0	5161381	5161390	5161403	5161898	5162179
5.0	5161383	5161391	5161404	5161901	5162180
6.0	5161384	5161393	5161405	5161902	5162181
7.0	5161385	5161394	5161406	5161903	5162182
8.0	5161386	5161395	5161407	5161904	5162184
9.0	5161387	5161396	5161408	5161905	5162185
10.0	5161388	5161397	5161409	5161910	5162186
11.0		5161398	5161410	5161911	5162187
12.0		5161399	5161411	5162161	5162188
13.0		5161400	5161412	5162162	5162189
14.0			5161413	5162166	5162190
15.0			5161414	5162170	5162191
16.0			5161416	5162172	5162192
17.0				5162173	5162193
18.0				5162174	5162205
19.0				5162175	5162206
20.0				5162176	5162207
21.0					5162208
22.0					5162209
23.0					5162210
24.0					5162211
25.0					5162212
26.0					5162213

Bestellbeispiel: / How to order :

ERC16-6.0 or 5161384

## Spannmutter ERB DIN 6499 Clamping nut ERB to DIN 6499-balanced

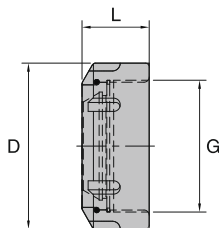

Bezeichnung Designation	Abmessung Size	D (mm)	L (mm)	G	Ident. No.
ERB25-HP	2-16	42	20.0	M32X1.5	5104121
ERB32-HP	2-20	50	22.5	M40X1.5	5104122
ERB40-HP	3-26	63	25.5	M50X1.5	5104123

Spannmutter ER  
Clamping nut ER

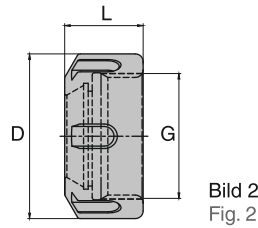
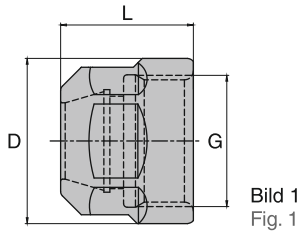

Abmessung Size	D	L	G	Bild Fig	Bezeichnung Designation	Ident No.
1-7	19.0	11.0	M14 X 0.75	1	ER11	5119412
1-10	28.0	17.5	M22X1.5	1	ER16	4600340
1-13	34.0	19.0	M25X1.5	1	ER20	5056874
2-16	42.0	20.0	M32X1.5	2	ER25	4600341
2-20	50.0	22.5	M40X1.5	2	ER32	4600342
3-26	63.0	25.5	M50X1.5	2	ER40	4600343

Spannmutter "Mini" ER  
Clamping nut "Mini" ER

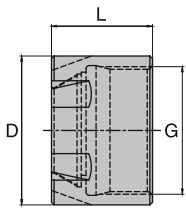

Abmessung Size	D	L	G	Bezeichnung Designation	Ident No.
1-7	16.0	12.0	M13X0.75	ER11M	5033469
1-10	22.0	18.5	M19X1.0	ER16M	6944416
1-13	28.0	19.0	M24X1.0	ER20M	6951224
2-16	35.0	20.0	M30X1.0	ER25M	6955533

Spannmutter ER für Dichtscheiben  
Clamping nut ER for sealing discs

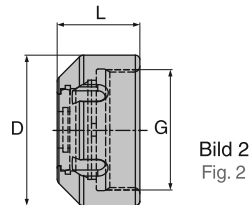
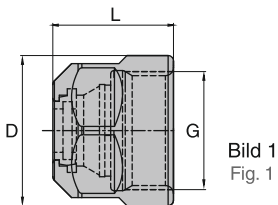

Abmessung Size	D	L	G	Bild Fig	Bezeichnung Designation	Ident No.
1-10	28.0	22.5	M22X1.5	1	ER16-IC	6931372
1-13	34.0	24.0	M25X1.5	1	ER20-IC	6931227
2-16	42.0	25.0	M32X1.5	2	ER25-IC	6941678
2-20	50.0	27.5	M40X1.5	2	ER32-IC	6933897
3-26	63.0	30.5	M50X1.5	2	ER40-IC	6948425

DS/ER Dichtscheiben für ER/ESX-Spannzange DIN6499-B  
 DS/ER Sealing disc for ER/ESX collet DIN6499-B



Bild  
Fig  
SD ER 16



Bild  
Fig  
SD ER 20

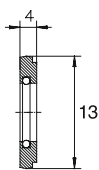

Bild  
Fig  
SD ER 25

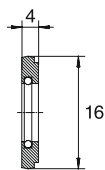

Bild  
Fig  
SD ER 32

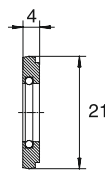

Bild  
Fig  
SD ER 40

Dichtebereich Sealing Range mm	Id. No. DS/ER 16 (bxa) 4x13 mm	Id. No. DS/ER 20 (bxa) 4x16 mm	Id. No. DS/ER 25 (bxa) 4x21 mm	Id. No. DS/ER 32 (bxa) 4x27 mm	Id. No. DS/ER 40 (bxa) 4x33,5 mm
3.0-2.5	6953629	6954178	6954181	6954194	6954264
3.5-3.0	6954176	6948385	6947674	6954195	6954265
4.0-3.5	6952696	6953235	6954182	6954112	6954266
4.5-4.0	6944324	6948386	6954183	6954196	6954267
5.0-4.5	6952972	6953236	6954184	6954113	6954268
5.5-5.0	6954177	6952104	6954185	6954197	6954269
6.0-5.5	6931371	6943901	6953215	6948674	6954270
6.5-6.0	6943060	6953031	6954186	6954198	6954271
7.0-6.5	6940533	6950178	6943420	6953637	6954272
7.5-7.0	6952195	6953237	6943421	6954199	6954273
8.0-7.5	6941539	6946991	6943419	6949999	6952197
8.5-8.0	6946898	6953238	6952198	6954200	6954274
9.0-8.5	6941992	6947339	6941679	6949298	6954275
9.5-9.0	6946897	6954179	6946744	6954201	6954276
10.0-9.5	6942300	6931347	6943423	6948675	6952199
10.5-10.0		6952196	6954187	6952918	6954277
11.0-10.5		6944294	6943534	6948387	6954278
11.5-11.0		6953239	6954188	6951274	6954279
12.0-11.5		6943902	6943424	6946689	6954280
12.5-12.0		6954180	6954189	6951275	6954281
13.0-12.5		6947968	6948123	6952973	6954282
13.5-13.0			6954190	6954202	6954283
14.0-13.5			6943342	6946613	6954284
14.5-14.0			6954191	6954203	6954285
15.0-14.5			6954192	6954204	6954114
15.5-15.0			6954193	6954205	6954286
16.0-15.5			6943422	6946822	6946054
16.5-16.0				6954206	6954287
17.0-16.5				6954207	6954288
17.5-17.0				6954208	6954289
18.0-17.5				6946002	6946120
18.5-18.0				6954209	6952210
19.0-18.5				6954210	6954115
19.5-19.0				6954211	6954290
20.0-19.5				6933868	6952971
20.5-20.0					6954291
21.0-20.5					9071745
21.5-21.0					6954292
22.0-21.5					6949887
22.5-22.0					6952212
23.0-22.5					9071747
23.5-23.0					6954293
24.0-23.5					9071748
24.5-24.0					6954294
25.0-24.5					6948426
25.5-25.0					6954295
26.0-25.5					9072720

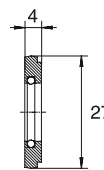
# Spannschlüssel Wrench

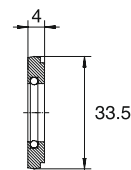
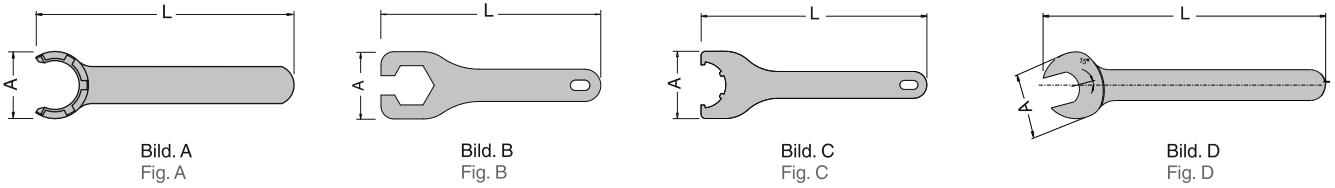

Bezeichnung Designation	für Spannmutter for Clamping Nut	A (mm)	L (mm)	Bild Fig	Ident. No.
E11M	ER11M-DIN 6499	16.8	90	A	6942650
E16M	ER16M-DIN 6499	22.5	110	A	6932510
E20M	ER20M-DIN 6499	29.0	120	A	6934089
E25M	ER25M-DIN 6499	36.0	130	A	6933989
E11P-17	ER11-DIN 6499	39.0	158	D	5105243
E16P-25	ER16-DIN 6499	44.0	145	B	5105244
E20	ER20-DIN 6499	52.0	170	B	6921607
E25	ER25-DIN 6499	65.0	210	C	6921608
E32	ER32-DIN 6499	75.0	252	C	6921609
E40	ER40-DIN 6499	90.0	292	C	6921610

• siehe Seite D17-D18 für Drehmomentschlüssel Spezifikationen

• Please refer page no.D17-D18 for torque wrench details



## Spannzangenfutter Typ ER Zylinderschaft Collet chuck Type ER With Cylinder Shank

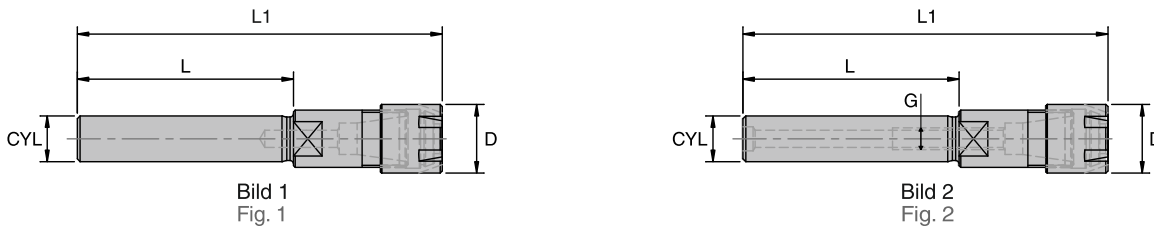

Abmessung Size	Spannzange Collet Type	Bereich Range	D (mm)	L (mm)	L1 (mm)	G	Bild Fig	Kühlmittelzufuhr Coolant supply	Bezeichnung Designation	Ident. No.
CYL 8	ER 11M	1-7	16	56	82.5		1	-	WCCH/ER11M-56/CYL8	5056876
CYL 10	ER 16M	1-10	22	60	98.5		1	-	WCCH/ER16M-60/CYL10	5056879
CYL 12	ER 11M	1-7	16	80	106.5		1	-	WCCH/ER11M-80/CYL12	5056880
CYL 16	ER 11M	1-7	16	100	121.0	M6	2	Form "AD"	WCCH/ER11M-100/CYL16	5056881
CYL 16	ER 11M	1-7	16	150	170.0	M6	2	Form "AD"	WCCH/ER11M-150/CYL16	66658855M
CYL 16	ER 16M	1-10	22	60	98.5	M8	2	Form "AD"	WCCH/ER16M-60/CYL16	5056882
CYL 16	ER 20M	1-13	28	100	142.5	M8	2	Form "AD"	WCCH/ER20M-100/CYL16	5056884
CYL 20	ER 16M	1-10	22	100	138.5	M10	2	Form "AD"	WCCH/ER16M-100/CYL20	5056885
CYL 20	ER 16M	1-10	22	150	188.5	M8	2	Form "AD"	WCCH/ER16M-150/CYL20	66658856M
CYL 20	ER 20M	1-13	28	150	192.5	M10	2	Form "AD"	WCCH/ER20M-150/CYL20	66658857M

Super collet Spannzangen - Zubehör für Super collet Spannzangenfutter  
 Super collet - Spare parts for Super collet chuck

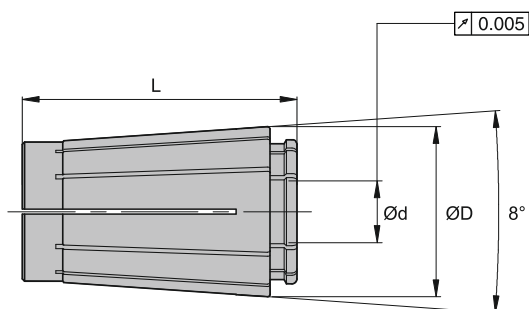

Spannzange Collet Type	Bereich Range	d (mm)	L (mm)	D (mm)	Ident No.
SC06-2.0	1.75-2.00	2.0	25	11	5103501
SC06-2.5	2.25-2.50	2.5	25	11	5103503
SC06-3.0	2.75-3.00	3.0	25	11	5103504
SC06-3.5	3.00-3.50	3.5	25	11	5103505
SC06-4.0	3.50-4.00	4.0	25	11	5103506
SC06-4.5	4.00-4.50	4.5	25	11	5103507
SC06-5.0	4.50-5.00	5.0	25	11	5103511
SC06-5.5	5.00-5.50	5.5	25	11	5103512
SC06-6.0	5.50-6.00	6.0	25	11	5103513
SC10-2.0	1.75-2.00	2.0	30	16	5103572
SC10-2.5	2.25-2.50	2.5	30	16	5103574
SC10-3.0	2.75-3.00	3.0	30	16	5103575
SC10-3.5	3.00-3.50	3.5	30	16	5103576
SC10-4.0	3.50-4.00	4.0	30	16	5103577
SC10-4.5	4.00-4.50	4.5	30	16	5103578
SC10-5.0	4.50-5.00	5.0	30	16	5103579
SC10-5.5	5.00-5.50	5.5	30	16	5103580
SC10-6.0	5.50-6.00	6.0	30	16	5103581
SC10-6.5	6.00-6.50	6.5	30	16	5103582
SC10-7.0	6.50-7.00	7.0	30	16	5103583
SC10-7.5	7.00-7.50	7.5	30	16	5103584
SC10-8.0	7.50-8.00	8.0	30	16	5103585
SC10-8.5	8.00-8.50	8.5	30	16	5103586
SC10-9.0	8.50-9.00	9.0	30	16	5103587
SC10-9.5	9.00-9.50	9.5	30	16	5103588
SC10-10.0	9.50-10.00	10.0	30	16	5103589
SC13-3.0	2.75-3.00	3.0	39	20	5103654
SC13-3.5	3.00-3.50	3.5	39	20	5103655
SC13-4.0	3.50-4.00	4.0	39	20	5103656
SC13-4.5	4.00-4.50	4.5	39	20	5103657
SC13-5.0	4.50-5.00	5.0	39	20	5103658
SC13-5.5	5.00-5.50	5.5	39	20	5103659
SC13-6.0	5.50-6.00	6.0	39	20	5103660
SC13-6.5	6.00-6.50	6.5	39	20	5103661
SC13-7.0	6.50-7.00	7.0	39	20	5103662
SC13-7.5	7.00-7.50	7.5	39	20	5103663
SC13-8.0	7.50-8.00	8.0	39	20	5103664
SC13-8.5	8.00-8.50	8.5	39	20	5103665
SC13-9.0	8.50-9.00	9.0	39	20	5103667
SC13-9.5	9.00-9.50	9.5	39	20	5103668
SC13-10.0	9.50-10.00	10.0	39	20	5103669
SC13-10.5	10.00-10.50	10.5	39	20	5103670
SC13-11.0	10.50-11.00	11.0	39	20	5103671
SC13-11.5	11.00-11.50	11.5	39	20	5103672
SC13-12.0	11.50-12.00	12.0	39	20	5103673
SC13-12.5	12.00-12.50	12.5	39	20	5103674
SC13-13.0	12.50-13.00	13.0	39	20	5103675

## Super collet Spannzangen - Zubehör für Super collet Spannzangenfutter

Super collet - Spare parts for Super collet chuck

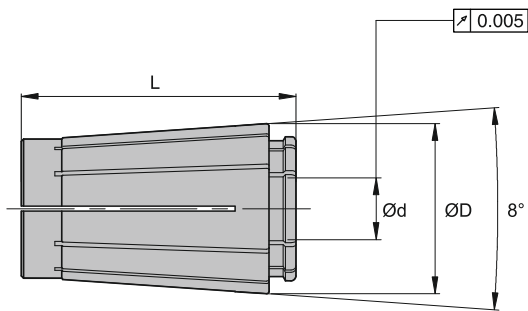

Spannzange Collet Type	Bereich Range	d (mm)	L (mm)	D (mm)	Ident No.
SC16-3.0	2.75-3.00	3.0	45	25	5103676
SC16-4.0	3.50-4.00	4.0	45	25	5103678
SC16-5.0	4.50-5.00	5.0	45	25	5103680
SC16-6.0	5.50-6.00	6.0	45	25	5103681
SC16-8.0	7.50-8.00	8.0	45	25	5103682
SC16-10.0	9.50-10.00	10.0	45	25	5103683
SC16-12.0	11.50-12.00	12.0	45	25	5103684
SC16-14.0	13.50-14.00	14.0	45	25	5175048
SC16-16.0	15.50-16.00	16.0	45	25	5103685
SC20-6.0	5.50-6.00	6.0	50	30	5103952
SC20-8.0	7.50-8.00	8.0	50	30	5103953
SC20-10.0	9.50-10.00	10.0	50	30	5103954
SC20-12.0	11.50-12.00	12.0	50	30	5103970
SC20-14.0	13.50-14.00	14.0	50	30	5103972
SC20-16.0	15.50-16.00	16.0	50	30	5103974
SC20-18.0	17.50-18.00	18.0	50	30	5103976
SC20-20.0	19.50-20.00	20.0	50	30	5103977
SC25-6.0	6.00-6.50	6.0	57	36	5104103
SC25-8.0	7.50-8.00	8.0	57	36	5104104
SC25-10.0	9.50-10.00	10.0	57	36	5104105
SC25-12.0	11.50-12.00	12.0	57	36	5104106
SC25-16.0	15.50-16.00	16.0	57	36	5104107
SC25-20.0	19.50-20.00	20.0	57	36	5104108
SC25-25.0	24.50-25.00	25.0	57	36	5104109

## Rollspannschlüssel

Friction Wrench

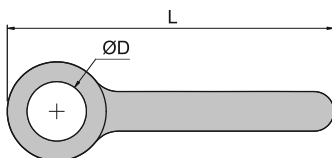

Bezeichnung Designation	Spannzange Collet Type	D (mm)	L (mm)	Ident No.
FW-D19.5	SCN06-FN	19.5	130	5102205
FW-D27.1	SCN10-FN	27.1	135	5103190
FW-D33	SCN13-FN	33.0	160	5102206
FW-D40	SCN16-FN	40.0	180	5102207
FW-D48	SCN20-FN	48.0	210	5103191
FW-D55	SCN25-FN	55.0	300	5102209

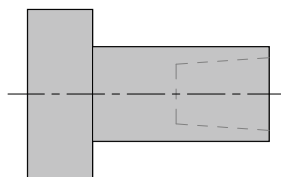

Spannzange Collet Type	Ident No.
SCP06	5152778
SCP10	5152779
SCP13	5152780
SCP16	5152781
SCP20	5152782
SCP25	5152783

Spannmutter für Rollspannschlüssel (für Super collet Spannzangenfutter)  
Friction Nut (for Super collet chuck)

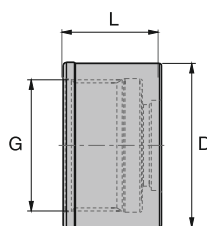

Spannzange Collet Type	Bereich Range	ØD (mm)	L (mm)	G (mm)	Ident No.
SCN06-FN	2.0-6.0	19.5	15	M15.5x1	5102199
SCN10-FN	2.0-10.0	27.1	17	M21.5x1	5102200
SCN13-FN	3.0-13.0	33.0	21	M27x1	5102201
SCN16-FN	4.0-16.0	40.0	24	M32x1.5	5102202
SCN20-FN	6.0-20.0	48.0	24	M40x1	5102203
SCN25-FN	6.0-25.0	55.0	30	M45x1.5	5102204

Super collet Spannzangenfutter mit innerer Kühlmitteldurchführung  
 Super collet chuck with internal coolant

Dichtscheibe  
 Sealing disc

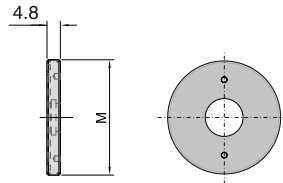

Dichtebereich Sealing Range mm	Id. No. SD-SC06 M16x1	Id. No. SD-SC10 M22x1	Id. No. SD-SC13 M28x1	Id. No. SD-SC16 M34x1	Id. No. SD-SC20 M36x1	Id. No. SD-SC25 M42x1
4.0	5152620	5152739	5152744	5152750		
5.0	5152622	5152740	5152745	5152751		
6.0	5152738	5152741	5152746	5152752	5152757	5152763
8.0		5152742	5152747	5152753	5152758	5152765
10.0		5152743	5152748	5152754	5152759	5152766
12.0			5152749	5152755	5152760	5152767
16.0				5152756	5152761	5152768
20.0					5152762	5152769
25.0						5152770

Spannmutter mit innerer Kühlung für Dichtscheibe  
 Friction nut with internal coolant

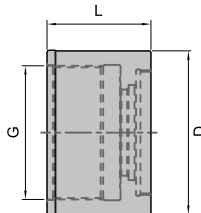

Spannzange Collet Type	Bereich Range	ØD (mm)	L (mm)	G (mm)	Ident No.
SCN06-IC-FN	2.0-6.0	19.5	20	M15.5x1	5152771
SCN10-IC-FN	2.0-10.0	27.1	22	M21.5x1	5152772
SCN13-IC-FN	3.0-13.0	33.0	26	M27x1	5152773
SCN16-IC-FN	4.0-16.0	40.0	29	M32x1.5	5152774
SCN20-IC-FN	6.0-20.0	48.0	29	M40x1	5152775
SCN25-IC-FN	6.0-25.0	55.0	35	M45x1.5	5152776

Stirnlochschlüssel  
 Adjustable pin wrench



Spannzange Collet Type	Ident No.
GWA0	6721800



Zylindrische Spannzange mit Längennachstellung  
Adjustable Straight Collet

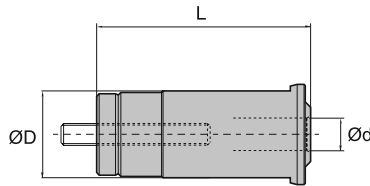

D (mm)	d (mm)	L (mm)	Bezeichnung Designation	Ident No.
20	6	63	WSC 20-06	5056814
20	8	63	WSC 20-08	5056817
20	10	63	WSC 20-10	5056818
20	12	63	WSC 20-12	5056819
20	14	63	WSC 20-14	5120883
20	16	63	WSC 20-16	5056820
25	6	73	WSC 25-06	5056821
25	8	73	WSC 25-08	5056822
25	10	73	WSC 25-10	5056823
25	12	73	WSC 25-12	5056824
25	14	73	WSC 25-14	5173498
25	16	73	WSC 25-16	5056825
25	18	73	WSC 25-18	5056827
25	20	73	WSC 25-20	5056828
32	6	79	WSC 32-06	5056829
32	8	79	WSC 32-08	5056830
32	10	79	WSC 32-10	5056831
32	12	79	WSC 32-12	5056832
32	14	79	WSC 32-14	5120884
32	16	79	WSC 32-16	5056833
32	18	79	WSC 32-18	5056834
32	20	79	WSC 32-20	5056835
32	25	79	WSC 32-25	5056836

Spannschlüssel  
Wrench

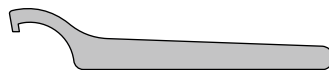

( für Größen ) (For size)	Bezeichnung Designation	Ident No.
WHPMC 20	C-20	5056838
WHPMC 25	C-25	5056839
WHPMC 32	C-32	5056840

• siehe Seite D17-D18 für Drehmomentschlüssel Spezifikationen

• Please refer page no.D17-D18 for torque wrench details

Ersatzteile für Schlanke Hochleistungsfräserspannfutter  
Spare Parts for Slim Hi-power milling chuck

Zylindrische Spannzange mit Längennachstellung  
Adjustable Straight Collet (for Slim Hi-Power Milling Chuck)

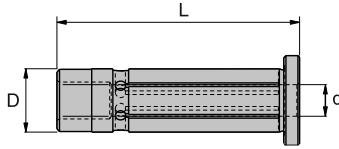

D (mm)	d (mm)	L (mm)	Bezeichnung Designation	Ident No.
20	6	63	WSC-S20-06	5108526
20	8	63	WSC-S20-08	5108527
20	10	63	WSC-S20-10	5108528
20	12	63	WSC-S20-12	5108529
20	16	63	WSC-S20-16	5108531

Rollspannschlüssel (für schlanke Hochleistungsfräserspannfutter)  
Friction wrench (for Slim Hi-Power Milling Chuck)

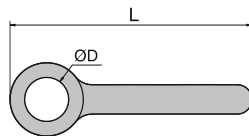

Größe Size	d (mm)	D (mm)	L (mm)	Bezeichnung Designation	Ident No.
S06, S08	06	25	135	FW-D25	5106044
S10, S12	12	30	150	FW-D30	5097511
S16	16	38	180	FW-D38	5097513
S20	20	44	210	FW-D44	5097514

• siehe Seite D17-18 für Drehmomentschlüssel Spezifikationen

• Please refer page no.D17-D18 for torque wrench details

Ersatzteile für Hydrodehnspannfutter (WHEC)  
Spare Parts for Hydraulic expansion chuck (WHEC)

WHC - Reduzierbuchsen  
WHC - Reduction sleeves

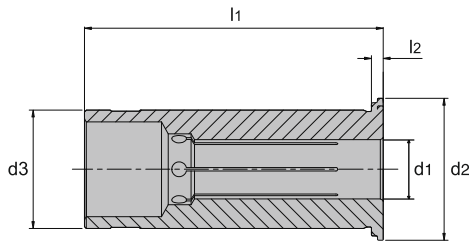

d1 (mm)	d2 (mm)	d3 (mm)	l1 (mm)	l2 (mm)	Innere Kühlmittelzufuhr / Internal coolant supply Bezeichnung / Designation	Ident No.
3	19	12	45,0	2	WHC12-3	9142752
4	19	12	45,0	2	WHC12-4	9142753
5	19	12	45,0	2	WHC12-5	9142754
6	19	12	45,0	2	WHC12-6	9142755
8	19	12	45,0	2	WHC12-8	9142756
3	29	20	50,5	2	WHC20-3	9142758
4	29	20	50,5	2	WHC20-4	9142779
5	29	20	50,5	2	WHC20-5	9142780
6	29	20	50,5	2	WHC20-6	9142781
7	29	20	50,5	2	WHC20-7	9142782
8	29	20	50,5	2	WHC20-8	9142784
9	29	20	50,5	2	WHC20-9	9142785
10	29	20	50,5	2	WHC20-10	9142786
11	29	20	50,5	2	WHC20-11	9142787
12	29	20	50,5	2	WHC20-12	9142788
13	29	20	50,5	2	WHC20-13	9142799
14	29	20	50,5	2	WHC20-14	9142800
15	29	20	50,5	2	WHC20-15	9142801
16	29	20	50,5	2	WHC20-16	9142802
6	39	32	60,5	3	WHC32-6	9142804
8	39	32	60,5	3	WHC32-8	5069815
10	39	32	60,5	3	WHC32-10	9142809
12	39	32	60,5	3	WHC32-12	9142810
14	39	32	60,5	3	WHC32-14	9142811
16	39	32	60,5	3	WHC32-16	9142812
18	39	32	60,5	3	WHC32-18	9142813
20	39	32	60,5	3	WHC32-20	9142814
25	39	32	60,5	3	WHC32-25	9142815

• Bei innerer Kühlmittelzufuhr: Bund geschlossen, Kühlmitteldicht bis max. 80 bar • For internal coolant supply: Closed collar, coolant proof up to max. 80 bar

WHC/WZ - Ausziehwerkzeug für Reduzierbuchsen  
WHC/WZ - Sleeve remover

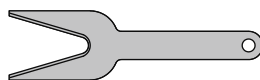

Bezeichnung Designation	Ident No.
HGR/WZ	9142854

Einschraubfräser Verlängerung  
Threaded arbor extensions

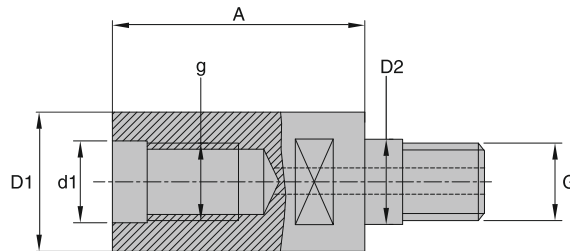

g / G (mm)	d1 / D2 (mm)	A (mm)	D1 (mm)	Bezeichnung Designation	Ident No.
M8	8.5	40	13,8	WTA/M8-40/M8	5056841
M8	8.5	60	13,8	WTA/M8-60/M8	5056842
M10	10.5	40	18,0	WTA/M10-40/M10	5056843
M10	10.5	60	18,0	WTA/M10-60/M10	5056844
M12	12.5	40	21,0	WTA/M12-40/M12	5056845
M12	12.5	60	21,0	WTA/M12-60/M12	5056846
M16	17.0	40	29,0	WTA/M16-40/M16	5056847
M16	17.0	60	29,0	WTA/M16-60/M16	5056848

Einschraubfräser Reduzierung  
Threaded arbor reductions

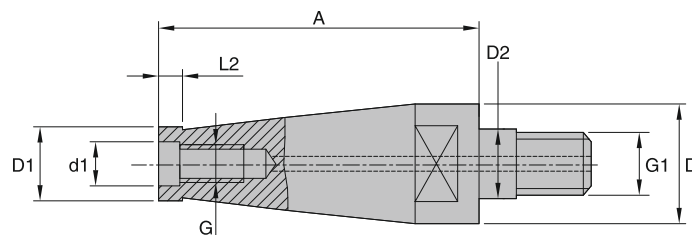

G (mm)	G1 (mm)	D2 (mm)	d1 (mm)	A (mm)	D1 (mm)	D (mm)	L2 (mm)	Bezeichnung Designation	Ident No.
M5	M8	8,5	5,5	40	10,0	13,0	6	WTA/M5-40/M8	5056849
M8	M10	10,5	8,5	40	13,8	18,0	6	WTA/M8-40/M10	5056850
M8	M12	12,5	8,5	60	13,8	21,0	6	WTA/M8-60/M12	5056851
M10	M12	12,5	10,5	40	18,0	21,0	6	WTA/M10-40/M12	5056853
M10	M16	17,0	10,5	60	18,0	29,0	6	WTA/M10-60/M16	5056854
M12	M16	17,0	12,5	40	21,0	29,0	6	WTA/M12-40/M16	5056855

Ersatzteile für Mini-Spannzangenhalter (MCH)  
Spare parts for Mini collet holder (MCH)

Mini Spannzange Verlängerungen  
Mini collet extensions

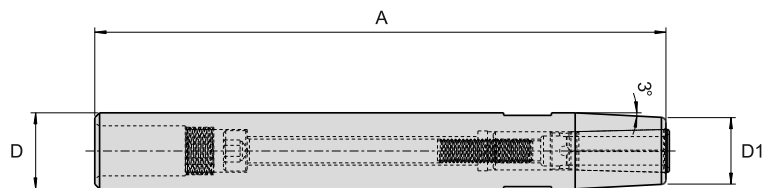

Spannzange Collet Type	Bereich Ø Range Ø	A (mm)	D (mm)	D1 (mm)	Bezeichnung Designation	Ident No.
MC14	3 - 6	90	16	14	WMCE/D14-90/CYL16	66658738M
MC14	3 - 6	120	16	14	WMCE/D14-120/CYL16	66658739M
MC14	3 - 6	160	16	14	WMCE/D14-160/CYL16	66658740M
MC14	3 - 6	200	16	14	WMCE/D14-200/CYL16	66658741M
MC14	3 - 6	120	20	14	WMCE/D14-120/CYL20	66658742M
MC14	3 - 6	160	20	14	WMCE/D14-160/CYL20	66658743M
MC14	3 - 6	200	20	14	WMCE/D14-200/CYL20	66658744M
MC21	3 - 6	120	25	21	WMCE/D21-120/CYL25	66658745M
MC21	3 - 6	160	25	21	WMCE/D21-160/CYL25	66658746M
MC21	3 - 6	200	25	21	WMCE/D21-200/CYL25	66658747M

Mini-Spannzange  
Mini collet

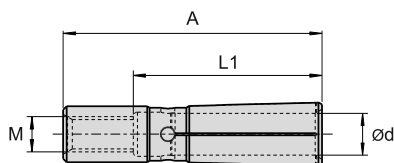

für Größe for Size	d (mm)	A (mm)	L1 (mm)	M (mm)	Spannschlüssel Wrench	Anzugsmoment Tightening Torque	Bezeichnung Designation	Ident No.
MC14	3	37	15	M5	W-D14x200L-HEX4.0	10Nm	WMC 14-3.0	66693301M
MC14	4	37	15	M5	W-D14x200L-HEX4.0	10Nm	WMC 14-4.0	66693302M
MC14	5	37	27	M5	W-D14x200L-HEX4.0	10Nm	WMC 14-5.0	66693303M
MC14	6	37	27	M5	W-D14x200L-HEX4.0	10Nm	WMC 14-6.0	66693304M
MC21	6	58	28	M8	W-D21x200L-HEX6.0	10Nm	WMC 21-6.0	66693305M
MC21	8	58	38	M8	W-D21x200L-HEX6.0	10Nm	WMC 21-8.0	66693306M
MC21	10	58	46	M8	W-D21x200L-HEX6.0	10Nm	WMC 21-10.0	66693307M
MC21	12	58	46	M8	W-D21x200L-HEX6.0	10Nm	WMC 21-12.0	66693308M

Spannschlüssel  
Wrench

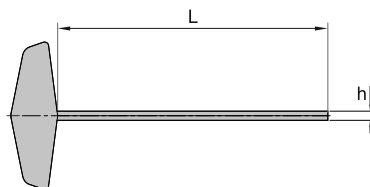

Bezeichnung Designation	Spannzange Collet Type	h (mm)	L (mm)	Ident No.
W-D14X200L-HEX4.0	MC14	4.0	200	5166592
W-D21x200L-HEX6.0	MC21	6.0	200	5229198

Drehmomentschlüssel  
Torque wrench



BT MAS 403  
ISO7388-2

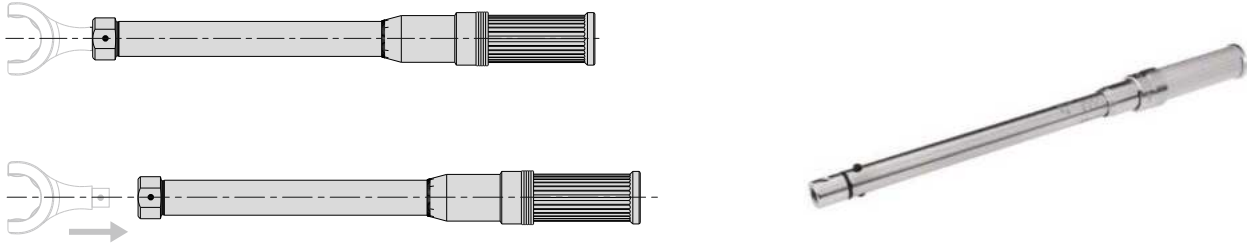

SK DIN 69871  
ISO7388-1

Bezeichnung Designation	Schaftgröße (mm) Shank size (mm)	Drehmoment (Nm) Torque range (Nm)	Inkrement (mm) Increment (Nm)	Länge x Ø (mm) Length x Ø (mm)	Ident. No.
TW01-9x12-5-25	9 x 12	5-25	0.2	248 x 22	5224502
TW02-9x12-20-100	9 x 12	20-100	0.5	445.5 x 22	5224507
TW03-14x18-40-220	14 x 18	40-220	1.0	481 x 32	5224511

HSK DIN 69893

Anzugsmoment Diagramm  
Tightening Torque Chart

Type	Spannbereich Clamping Range Ø	Auszugsmoment (Nm) Tightening Torque (Nm)			Schlüssel Suitable for Wrench	Drehmoment- schlüssel Suitable Torque wrench	Aufsteckschlüssel passend für Drehmomentschlüssel Suitable Torque wrench head
		ER Nut	ERM Nut	ERB Nut			
<b>Spannzangenfutter ER / Collet Chuck ER</b>							
ER11	1.0 - 3.0	8	8	-	E11P-17	TW01-9x12-5-25	TWH-E11M, TWH-E11
	3.0 - 7.0	24	16	-	E11P-17	TW01-9x12-5-25	TWH-E11M, TWH-E11
ER16	1.0	8	8	-	E16P-25	TW01-9x12-5-25	TWH-E16M, TWH-E16
	1.5 - 3.5	20	20	-	E16P-25	TW01-9x12-5-25	TWH-E16M, TWH-E16
	4.0 - 4.5	40	25	-	E16P-25	TW02-9x12-20-100	TWH-E16M, TWH-E16
	5.0 - 10.0	56	25	-	E16P-25	TW02-9x12-20-100	TWH-E16M, TWH-E16
ER20	2.0 - 6.5	32	28	-	E20	TW02-9x12-20-100	TWH-E20M, TWH-E20
	7.0 - 13.0	80	28	-	E20	TW02-9x12-20-100	TWH-E20M, TWH-E20
ER25	2.0 - 3.5	25	25	25	E25	TW02-9x12-20-100	TWH-E25M, TWH-E25
	4.0 - 4.5	56	32	48	E25	TW02-9x12-20-100	TWH-E25M, TWH-E25
	5.0 - 7.5	80	32	72	E25	TW02-9x12-20-100	TWH-E25M, TWH-E25
	8.0 - 16.0	104	32	104	E25	TW03-14x18-40-220	TWH-E25M, TWH-E25
ER32	2.0 - 2.5	25	-	25	E32	TW02-9x12-20-100	TWH-E32-9x12
	3.0 - 7.5	136	-	128	E32	TW03-14x18-40-220	TWH-E32-14x18
	8.0 - 20.0	136	=	136	E32	TW03-14x18-40-220	TWH-E32-14x18
ER40	3.0 - 26.0	176	-	176	E40	TW03-14x18-40-220	TWH-E40
<b>Hochleistungsfräuserspannfutter / Hi-power milling chuck (HPMC)</b>							
HPMC	20				C-20	TW02-9x12-20-100	TWH-C-20
	25				C-25	TW02-9x12-20-100	TWH-C-25
	32				C-32	TW02-9x12-20-100	TWH-C-32

Zubehör  
Accessories

Ersatzteile  
Spare Parts

Technische Spezifikationen  
Technical Details

## Aufsteckschlüssel

Torque Wrench head (for ER range)



Bild. A  
Fig. A



Bild. B  
Fig. B

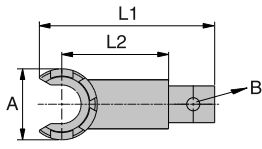

Bild. C  
Fig. C

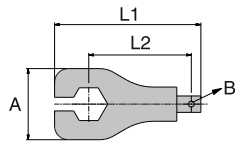

Bild. D  
Fig. D

Bezeichnung Designation	für Spannmutter for Clamping Nut	A (mm)	L1 (mm)	L2 (mm)	B (mm)	Bild Fig	Ident. No.
TWH-E11M	ER11M-DIN 6499	16.8	90	75	9x12	A	5172601
TWH-E16M	ER16M-DIN 6499	22.5	110	75	9x12	A	5172603
TWH-E20M	ER20M-DIN 6499	29.0	120	75	9x12	A	5172605
TWH-E25M-9x12	ER25M-DIN 6499	36.0	130	75	9x12	A	5172606
TWH-E25M-14X18	ER25M-DIN 6499	36.0	130	75	14x18	A	5224521
TWH-E11	ER11-DIN 6499	23.0	90	75	9x12	D	5172607
TWH-E16	ER16-DIN 6499	44.0	105	75	9x12	B	5172608
TWH-E20	ER20-DIN 6499	52.0	105	75	9x12	B	5172609
TWH-E25-9x12	ER25-DIN 6499	65.0	85	75	9x12	C	5172611
TWH-E25-14X18	ER25-DIN 6499	65.0	85	75	14x18	C	5224522
TWH-E32-9X12	ER32-DIN 6499	75.0	124	75	9x12	C	5172616
TWH-E32-14X18	ER32-DIN 6499	75.0	124	75	14x18	C	5172617
TWH-E40	ER40-DIN 6499	90.0	164	75	14x18	C	5172618

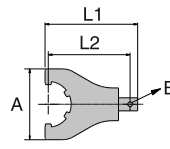
## Aufsteckschlüssel

Torque wrench head (for Hi-Power milling chuck)

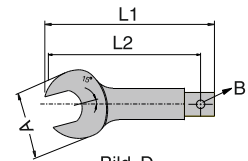
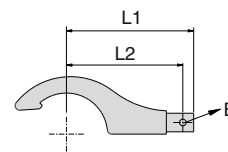

Bezeichnung Designation	( für Größen ) (For size)	L1 (mm)	L2 (mm)	(mm)	Ident No.
TWH-C-20	WHPMC 20	113	75	9x12	5172629
TWH-C-25	WHPMC 25	114	75	9x12	5172631
TWH-C-32	WHPMC 32	118	75	9x12	5172632

## Anzugsbolzen DIN 69872 A+B

Pull stud DIN 69872 A+B

Type A (Mit Durchgangsbohrung, ohne O-Ring)

Type A (With through hole, without O-ring)

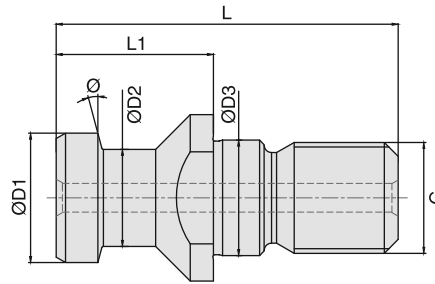

G	ØD1 (mm)	ØD2 (mm)	ØD3 (mm)	L (mm)	L1 (mm)	Ø	Bezeichnung Designation	Ident No.
M12	13.0	9.0	13.0	44.0	24.0	15°	BN 164 - SK 30	6733614
M16	19.0	14.0	17.0	54.0	26.0	15°	BN 164 - SK 40	6733615
M24	28.0	21.0	25.0	74.0	34.0	15°	BN 164 - SK 50	6733616

Type B (Ohne Durchgangsbohrung inkl. O-Ring)

Type B (without through hole, incl. O-ring)

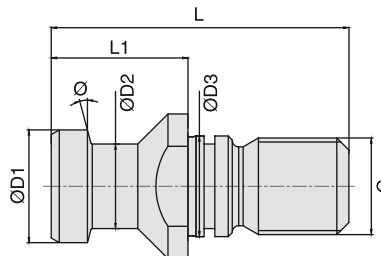

G	ØD1 (mm)	ØD2 (mm)	ØD3 (mm)	L (mm)	L1 (mm)	Ø	Bezeichnung Designation	Ident No.
M16	19.0	14.0	17.0	54.0	26.0	15°	BN 164B - SK 40	5056290
M24	28.0	21.0	25.0	74.0	34.0	15°	BN 164B - SK 50	5056292



## Anzugsbolzen MAS BT A+B

Pull stud MAS BT A+B

Type A (Ohne Durchgangsbohrung, ohne O-Ring)

Type A (Without through hole, without O-ring)

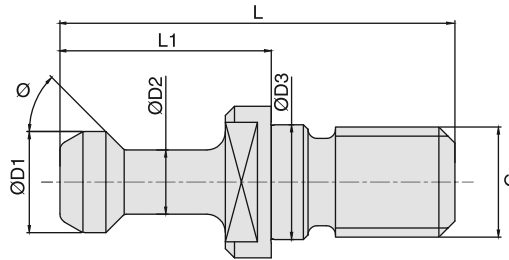

G	ØD1 (mm)	ØD2 (mm)	ØD3 (mm)	L (mm)	L1 (mm)	Ø	Bezeichnung Designation	Ident No.
M12	11.0	7.0	12.5	43.0	23.0	45°	BN 164 - BT 30	6733617
M16	15.0	10.0	17.0	60.0	35.0	45°	BN 164 - BT 40	6733618
M24	23.0	17.0	25.0	85.0	45.0	45°	BN 164 - BT 50	6733619
M12	11.0	7.0	12.5	43.0	23.0	60°	BN 164 - BT 30-60	4600614
M16	15.0	10.0	17.0	60.0	35.0	60°	BN 164 - BT 40-60	4600882
M24	23.0	17.0	25.0	85.0	45.0	60°	BN 164 - BT 50-60	4601402
M16	15.0	10.0	17.0	60.0	35.0	90°	BN 164 - BT 40-90	4600959
M24	23.0	17.0	25.0	85.0	45.0	90°	BN 164 - BT 50-90	4601404

Type B (mit Durchgangsbohrung inkl. O-Ring)

Type B (with through hole, incl. O-ring)

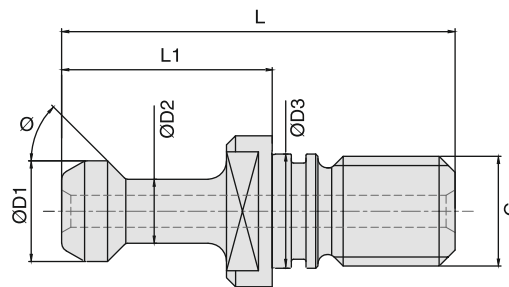

G	ØD1 (mm)	ØD2 (mm)	ØD3 (mm)	L (mm)	L1 (mm)	Ø	Bezeichnung Designation	Ident No.
M12	11.0	7.0	12.5	43.0	23.0	45°	BN 164B - BT 30	4600613
M16	15.0	10.0	17.0	60.0	35.0	45°	BN 164B - BT 40	4600957
M24	23.0	17.0	25.0	85.0	45.0	45°	BN 164B - BT 50	4601460
M12	11.0	7.0	12.5	43.0	23.0	60°	BN 164B - BT 30-60	5084973
M16	15.0	10.0	17.0	60.0	35.0	60°	BN 164B - BT 40-60	4600958
M24	23.0	17.0	25.0	85.0	45.0	60°	BN 164B - BT 50-60	4601461
M16	15.0	10.0	17.0	60.0	35.0	90°	BN 164B - BT 40-90	5084974
M24	23.0	17.0	25.0	85.0	45.0	90°	BN 164B - BT 50-90	4602462

Kühlmittelrohr für HSK-Spannfutter. Zur Kühlmittelübergabe bei HSK-Werkzeugen inkl. Runddichtung DIN 3770 und Überwurfmutter  
 Coolant tube for HSK chuck  
 For coolant transfer in HSK tools incl. round gasket DIN 3770 and union nut

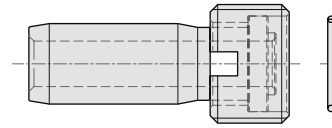

HSK-Größen HSK Size	Bezeichnung Designation	Ident No.
HSK 32	UE4/HSK32	5064893
HSK 40	UE4/HSK40	5028425
HSK 50	UE4/HSK50	5028426
HSK 63	UE4/HSK63	5025376
HSK 80	UE4/HSK80	5028427
HSK 100	UE4/HSK100	5028428

Montageschlüssel für Kühlmittelrohr  
 Installation wrench for coolant pipe

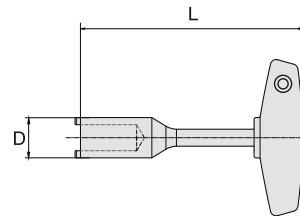

HSK-Größen HSK Size	D (mm)	L (mm)	Ident No.
HSK 32	8.5	115	6738740
HSK 40	10.5	115	6738741
HSK 50	14.5	115	6738422
HSK 63	16.5	136	6738421
HSK 80	18.5	136	6738095
HSK 100	22.0	136	6738303

Spannschlüssel DIN 6368  
 Spanner to DIN 6368 (Shell mill holder)

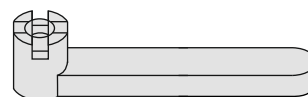

d (mm) (für Größe) (for Size)	Bezeichnung Designation	Ident No.
16	DIN6368-16	5056946
22	DIN6368-22	6942963
27	DIN6368-27	6942916
32	DIN6368-32	6942917
40	DIN6368-40	6950689

Spannschlüssel  
 Wrench (Shell mill holder)

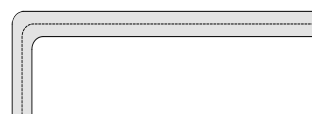

d (mm) ( für Größen / for Size )	Bezeichnung Designation	Ident No.
16	SW6	6737650
22	SW8	6737651
27	SW10	6737652
32	SW14	6737654
40	SW17	6737655

**Vorteile des Montageblocks**

- Sicheres klemmen
- Ermöglicht das Klemmen von verschiedenen Maschinenschnittstellen
- Reibschlussverfahren
- Einfache und schnelle Werkzeugmontage

**Advantages**

- Secured tool clamping
- Supports clamping of different taper interfaces
- Friction clamping method
- Easy and quick better tool assembly



Spannfutter kann mit einem Handgriff gespannt werden, keine weiteren Werkzeuge sind nötig

Tool holder can be locked in the fixture with just a hand twist and no additional tools required

Mit 3 Schrauben sicheram Tisch befestigt

3 bolts are mounted securely to the table



Bezeichnung Designation	Ident No.
TAD-D46	5216500
TAD-D50	5216499
TAD-D63	5192227
TAD-D100	5216027

Spannfutter kann mit einem Handgriff gespannt werden, keine weiteren Werkzeuge sind nötig

Mit 3 Schrauben sicher am Tisch befestigt

Tool holders can be locked in the fixture with just a hand twist and no additional tools required

3 bolts are securely mounted onto the table

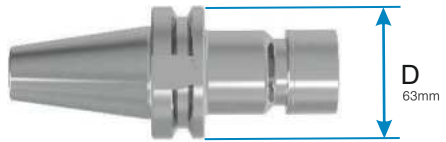

**TAD-D46**

Der Montageblock ist für diverse Schnittstellen geeignet,

- BT-30 tool holders
- FBT-30 tool holders

**TAD-D46**

This tool assembly device is suitable for all tapers with diameter 46mm like,

- BT-30 tool holders
- FBT-30 tool holders

**TAD-D50**

Der Montageblock ist für diverse Schnittstellen geeignet,

- SK-30 tool holders
- HSK-50 tool holders

**TAD-D50**

This tool assembly device is suitable for all tapers with diameter 50mm like,

- SK-30 tool holders
- HSK-50 tool holders

**TAD-D63**

Der Montageblock ist für diverse Schnittstellen geeignet,

- BT-40 tool holders
- FBT-40 tool holders
- SK-40 tool holders
- CAT-40 tool holders
- HSK-A-63 tool holders
- HSK-F-63 tool holders

**TAD-D63**

This tool assembly device is suitable for all tapers with diameter 63mm like,

- BT-40 tool holders
- FBT-40 tool holders
- SK-40 tool holders
- CAT-40 tool holders
- HSK-A-63 tool holders
- HSK-F-63 tool holders

**TAD-D100**

Der Montageblock ist für diverse Schnittstellen geeignet,

- BT-50 tool holders
- FBT-50 tool holders
- HSK-A-100 tool holder

**TAD-D100**

This tool assembly device is suitable for all tapers with diameter 100mm like,

- BT-50 tool holders
- FBT-50 tool holders
- HSK-A-100 tool holders

für Weldon und Whistle Notch for Weldon & whistle notch holder	E2
für Kombi und Aufsteckfräserdorne for Combi & shell mill holder	E3 - E4
für Morse-Kegel mit Anzugsgewinde for Morse taper with thread	E5 - E6
für Zwischenhülsen for Reduction sleeves	E7

Spannschraube für Weldon und Whistle Notch Spannfutter DIN 1835 B  
 Locking screw for Weldon & Whistle Notch to DIN 1835 B

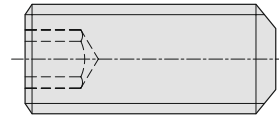

d (mm) (für Größe) (for Size)	Bezeichnung Designation	Ident No.
16*	DIN1835-B-M14x14	5056294
20*	DIN1835-B-M16x12	5056295
25* & 32*	M16x1x10.5	5056296
25* & 32*	M16x1x8.5	5056297
32*	DIN1835-B-M20x2x16	5056298
6	DIN1835-B-M6x10	6919658
8	DIN1835-B-M8x10	6919659
10	DIN1835-B-M10x12	6919660
12 & 14	DIN1835-B-M12x16	6919661
16 & 18	DIN1835-B-M14x16	6919662
20	DIN1835-B-M16x16	6924584
25	DIN1835-B-M18x2x20	6919664
32 & 40	DIN1835-B-M20x2x20	6919665

\* For short GPL's  
 \* Für kurze Vorbaulänge

Anschlagschraube durchbohrt für Whistle Notch Aufnahmen  
 Adjusting screw with coolant hole for Whistle Notch holder

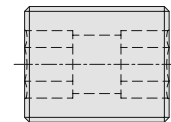

d (mm) (für Größe) (for Size)	Bezeichnung Designation	Ident No.
6	M5x15	5056887
8	M6x15	5056888
10	M8x15	5056889
12 & 14	M10x15	5056891
16 & 18	M12x15	5056893
20	M16x15	5056894
25, 32 & 40	M20x15	5056895

Ersatzteile für Kombi und Aufsteckfräserdorn  
Spare parts for Combi & Shell mill holder

Fräseranzugsschraube DIN 6367  
Clamping screw to DIN 6367

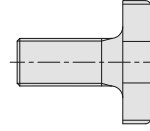

d (mm) (für Größe) (for Size)	Bezeichnung Designation	Ident No.
16	DIN6367-M8	6934073
22	DIN6367-M10	6940383
27	DIN6367-M12	6941541
32	DIN6367-M16	6942757
40	DIN6367-M20	6943111
50	DIN6367-M24	5111255

Mitnehmerring DIN 6366  
Drive ring to DIN 6366

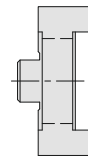

d (mm) (für Größe) (for Size)	Bezeichnung Designation	Ident No.
16	DIN6366-C16	5056898
22	DIN6366-C22	5056900
27	DIN6366-C27	5056901
32	DIN6366-C32	5056903
40	DIN6366-C40	5056904

Passfeder DIN 6885  
Parallel key to DIN 6885

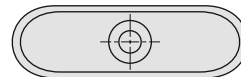

d (mm) (für Größe) (for Size)	Bezeichnung Designation	Ident No.
16	DIN6885-C4x4x20	5056905
22	DIN6885-C6x6x25	5056909
27	DIN6885-C7x7x25	5056610
32	DIN6885-C8x7x28	5056911
40	DIN6885-C10x8x32	5056912

**Gewindestift DIN 913**  
Threaded stud to DIN 913

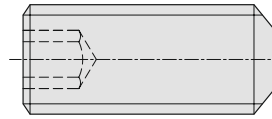

d (mm) (für Größe) (for Size)	Bezeichnung Designation	Ident No.
16	DIN913-M3x3	6914425
22, 27, 32	DIN913-M3x5	6951794
40	DIN913-M3x7	5056913

**Paßfeder**  
Drive keys

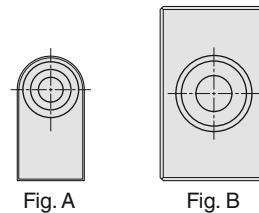

d (mm) (für Größe) (for Size)	Bezeichnung Designation	Fig.	Ident No.
16	Dia16-8x8x14	Fig. A	5057289
22	Dia22-10x10x17	Fig. A	5057290
27	Dia27-12x14x20	Fig. A	5057291
32	Dia32-14x14x22	Fig. A	5057293
40	Dia40-15.9x16x21	Fig. B	5057294
60	Dia60-25.4x25x31	Fig. B	5057295

**Innensechskantschraube DIN 912**  
Socket head screw to DIN 912

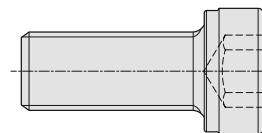

d (mm) (für Größe) (for Size)	Bezeichnung Designation	Ident No.
16	DIN912-M3x8	6914489
22	DIN912-M4x8	6918335
27	DIN912-M4x14	6941122
32	DIN912-M5x13	5056916
40	DIN912-M6x16	6900224
60	DIN912-M12x25	6914503



Ersatzteile für Morse-Kegel mit Anzugsgewinde  
Spare Parts for Morse taper with thread

Innensechskantschraube  
Socket Head Screw

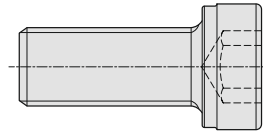

Kegelgröße Taper Size (SK/BT/ISO)	MK	Bezeichnung Designation	Ident No.
40 & 50	1	M6x21	5056917
	2	M10x30	5089591
	3	M12x40	6918327
	4	M16x40	6924372
	5	M20x60	5056918

Rückschlagschraube  
Stopper Screw

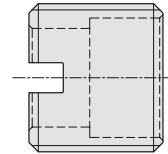

Kegelgröße Taper Size (SK/BT/ISO)	MK	Bezeichnung Designation	Ident No.
40 & 50	1	M16x10	5057297
	2	M16x8	5057299
	3	M20x1.5x10	5057300
	4	M26x1.5x10	5057301
	5	M36x2.5x15	5057305

Gewindestift DIN 913  
Threaded stud DIN 913

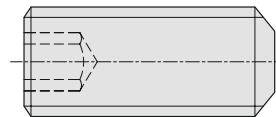

Kegelgröße Taper Size (SK/BT/ISO)	MK	Bezeichnung Designation	Ident No.
40 & 50	1	DIN913-M5x6	6900216
	2	DIN913-M5x6	6900216
	3	DIN913-M5x6	6900216
	4	DIN913-M5x6	6900216
	5	DIN913-M5x6	6900216

Ersatzteile für Morse-Kegel mit Anzugsgewinde  
Spare Parts for Morse taper with thread

Innensechskantschraube  
Socket Head Screw

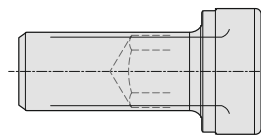

Kegelgröße Taper Size (HSK)	MK	Bezeichnung Designation	Ident No.
A63 & A100	1	M06x20	6914495
	2	M10x30	6933092
	3	M12x30	6922632
	4	M16x45	6933120
	5	DIN912-IC-M20x55	5089579

Rückschlagschraube  
Stopper Screw

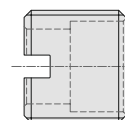

Kegelgröße Taper Size (HSK)	MK	Bezeichnung Designation	Ident No.
A63 & A100	1	M10x1.0x6-LH	5059807
	2	M15x1.5x6-LH	5059811
	3	M20x1.5x6-LH	5059812
	4	M24x1.5x8.5-LH	5059813
	5	M26x2.0x11-LH	5059814

Ersatzteile für Zwischenhülsen  
Spare Parts for Reduction Sleeves

Innensechskantschraube  
Socket Head Screw

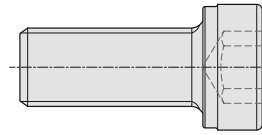

Kegelgröße Taper Size (SK/BT)	Innenkegelgröße Inside Taper	Bezeichnung Designation	Ident No.
SK40/BT40	SK 30	DIN912-M12x40	5089589
SK40/BT40	SK 40	DIN912-M16x60	6929756
SK50/BT50	SK 40	DIN912-M16x50	6912389
SK50/BT50	SK 50	DIN912-M24x85	5056920

Rückschlagschraube  
Stopper Screw

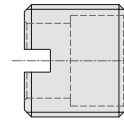

Kegelgröße Taper Size (SK/BT/ISO)	Innenkegelgröße Inside Taper	Bezeichnung Designation	Ident No.
40	30	M18x1.5x10	5057303
	40	M26x1.5x13	5057304
50	40	M26x1.5x13	5057304
	50	M36x2.0x15	5057302

Gewindestift DIN 913  
Threaded Stud DIN 913

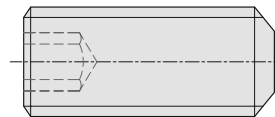

Bezeichnung Designation (SK/BT/ISO)	Ident No.
DIN913-M5x6	6900216

Spannmuttern - Betriebsanleitung Clamping Nut - Instructions	F2
DS/ER Dichtscheibe - Betriebsanleitung DS/ER Sealing disc - Instructions	F3
Hochleistungsfräserspannfutter - Zusätze und Vorteile Hi-Power Milling Chuck - Features & Advantages	F4 - F5
Super collet Spannzangenfutter - Vorteile Super collet chuck - Advantages	F6 - F7
Werkzeugschaft DIN 69871 / ISO7388-1 (SK) Tool Shank to DIN 69871 / ISO7388-1 (SK)	F8
Werkzeugschaft JIS B 6339 (MAS 403 BT) Tool Shank to JIS B 6339 (MAS 403 BT)	F8
Kühlmittelezufuhr – Umbauanleitung Coolant Supply - Instruction for change	F9
Übersicht Werkzeugschäfte DIN 69893 (HSK) Overview tool shanks DIN 69893 (HSK)	F10 - F11
Wuchtgüte Balancing Standard	F12
Wichtige Bestellhinweise Important Hints	F13

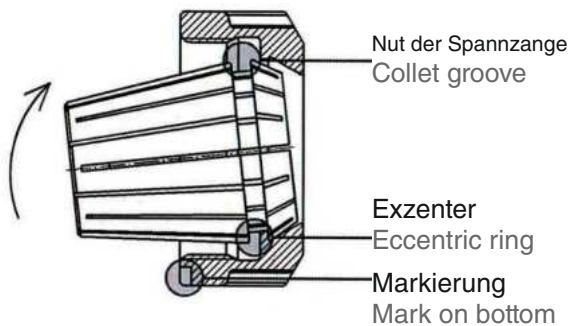
**Montageanleitung**

Nut der Spannzange an der markierten Stelle in den Exzentering der Spannmutter einhängen. Spannzange in entgegengesetzte Richtung kippen, bis diese deutlich hörbar einrastet. Werkzeug einsetzen.

Spannmutter mit der eingerasteten Spannzange auf das Gewinde des Halters schrauben. Wir empfehlen, die Spannmutter mit einem Drehmomentschlüssel anzuziehen.

**Assembling Collet:**

Insert groove of the collet into eccentric ring of the clamping nut at the mark on the bottom of the nut. Push collet in the direction of the arrow until it clicks in.

Insert tool. Screw nut with collet onto tool holder.

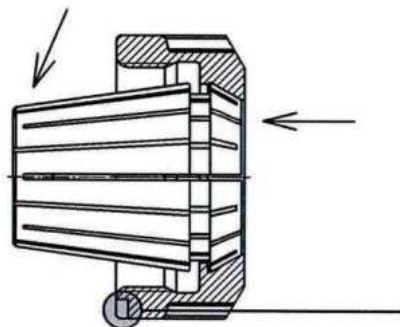
**Demontage**

Nach dem Abschrauben vom Halter auf die Frontseite der Spannzange drücken und gleichzeitig die Spannzange durch seitlichen Druck auf den hinteren Teil, gegenüber der Markierung, aus der Einrastung der Mutter heraus drücken.

**Removing Collet:**

After the nut is unscrewed from the toolholder, press on the face of the collet while simultaneously pushing sideways on the back of the collet opposite the mark until it disengages from the clamping nut.

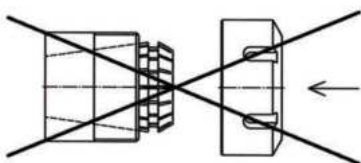

**! Eine falsche Handhabung beeinträchtigt den Rundlauf der Spannzange und kann die Spannmutter beschädigen.**

**Nur Spannmuttern mit richtig eingerasteter Spannzange in den Spannzangenhalter einsetzen!**

**! Improper assembly can permanently damage the concentricity of the collet and may result in the destruction of the clamping nut.**

**Only mount nuts with correctly inserted collets!  
Never place the collet into the holder without first assembling into the nut.**

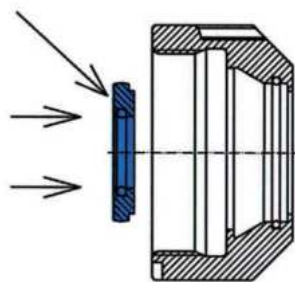

**Einbau**  
 Beim Einsetzen der Dichtscheibe in die Spannmutter muss die Beschriftung der Dichtscheibe von hinten her lesbar sein.

**Assembling**  
 Insert the small diameter of the disk into the center of the coolant nut and apply even pressure until the disk is properly seated into the nut.

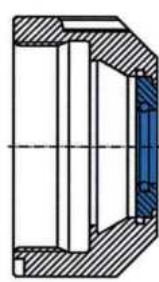

Dichtscheibe in die Spannmutter einlegen und nach vorne drücken, bis ein deutliches „Klicken“ zu hören ist. Jetzt ist die Dichtscheibe richtig in die Spannmutter eingesetzt. Die richtig montierte Dichtscheibe ist vorne mit der Spannmutter bündig.

The disk must be flush with the outside of the nut and the marking on the disk must be seen inside the nut.

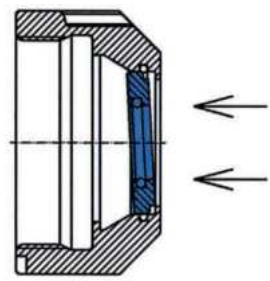

**Ausbau**  
 Um die Dichtscheibe herauszunehmen, von der Außenseite auf die Dichtscheibe drücken, bis sie herauspringt.

**Removing**  
 To remove the disk, simply press on the outside of the disk evenly until it snaps out.

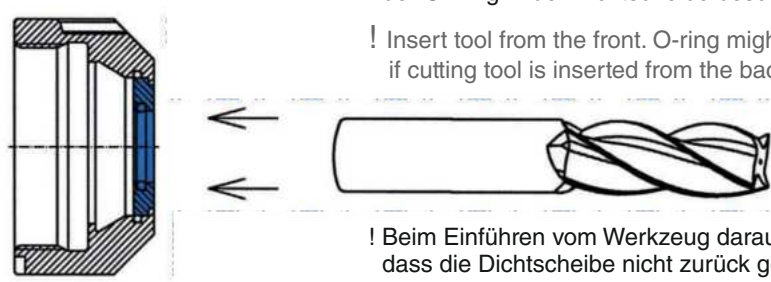

! Unbedingt Werkzeug von vorne einführen, sonst wird der O-Ring in der Dichtscheibe beschädigt.

! Insert tool from the front. O-ring might be destroyed if cutting tool is inserted from the back.

! Beim Einführen vom Werkzeug darauf achten, dass die Dichtscheibe nicht zurück geschoben wird.

! Take care when inserting the tool that you do not push back the sealing disc.

## Hochleistungsfräserspannfutter - Eigenschaften und Vorteile

### Hi-Power Milling Chuck - Features & Advantages

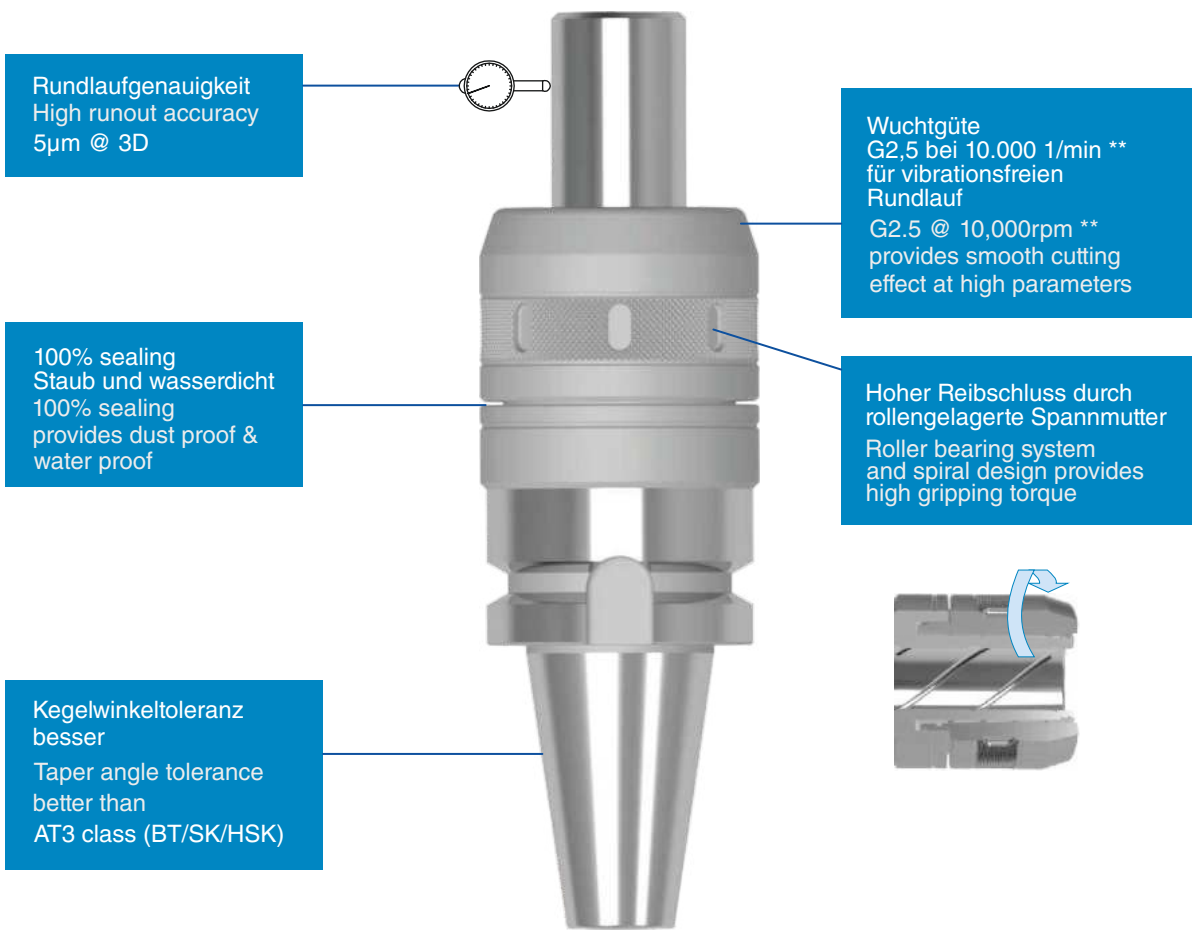

Zusätze und Vorteile	Features and Advantages
<ul style="list-style-type: none"> <li>• Sehr hohe Spannkraft führt zu verbesserter Produktivität und Standzeit</li> <li>• Geringe Reibung durch Konstruktion mit Rollenlager</li> <li>• Hohe Rundlaufgenauigkeit von 5µm bei 3D</li> <li>• Ausgezeichnete Oberflächenqualität da weniger Vibrationen</li> <li>• Ein neu entworfener Dichtmechanismus der Mutter verhindert Verunreinigung durch Staub und Kühlflüssigkeit, dadurch wird die Standzeit des Werkzeugs erhöht</li> </ul>	<ul style="list-style-type: none"> <li>• Very high gripping torque leads to increased productivity and tool life</li> <li>• Roller bearing system &amp; spiral design provides high gripping torque</li> <li>• High run-out accuracy 5 microns @ 3D. Less wear on cutting edge leads to significant increase in tool life</li> <li>• Excellent finish on machined surface due to less vibration</li> <li>• Perfect seal mechanism of clamping nut, prevents dust and coolant entry. Thereby, extending life of the holder</li> </ul>
<p>Note: ** Only the holders are balanced as mentioned in the catalogue without assembly</p>	

### Hi-Power Milling Chuck - Anzugsmomente und Spannkräfte / Torque chart

(für Größe) (for Size)	Anzugsmoment (Nm) Tightening Torque (Nm)	Spannkraft (Nm) Clamping Torque (Nm)	Schaft Ø (mm) Shank Ø (mm)
WHPMC 20	30	450 - 600	20h6
WHPMC 25	70	601 - 850	25h6
WHPMC 32	80	851 - 1050	32h6

### Slim Hi-Power Milling Chuck - Anzugsmomente und Spannkräfte / Torque chart

(für Größe) (for Size)	Anzugsmoment (Nm) Tightening Torque (Nm)	Spannkraft (Nm) Clamping Torque (Nm)	Schaft Ø (mm) Shank Ø (mm)
WHPMC S06	30	35 - 55	6h6
WHPMC S08	30	56 - 70	8h6
WHPMC S10	30	71 - 95	10h6
WHPMC S12	30	96 - 180	12h6
WHPMC S16	30	181 - 360	16h6
WHPMC S20	30	361 - 420	20h6

\* Nur zur direkten Montage.

\* For direct mounting only. These values are tested and valid with 100% locking (full contact of internal diameter of holder and the tool shank i.e., L1 dimension)

# Hochleistungsfräserspannfutter - Betriebsanleitung

## Hi-Power Milling Chuck - Operating Instructions

### Montage / Assembly

Stellen Sie sicher, dass bei der direkten Montage des Werkzeugs die Stellschraube im Spannfutter eingebaut ist, um den korrekten Sitz des Schneidwerkzeugs zu gewährleisten.

Please ensure that the adjusting screw is located before direct mounting of tool, as this ensures the correct seating of the cutting tool. Tool should rest on the adjusting screw.



Zum Montieren der Spannzange sollte die Stellschraube aus dem Spannfutter entfernt werden.

Please remove the adjusting screw before mounting the collet.

### Einspannen-Ausspannen / Clamping-UnClamping

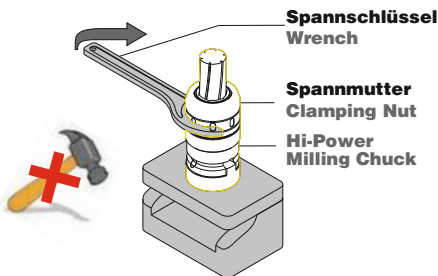

Die Spannmutter wird mit dem mitgelieferten Schlüssel gemäß Drehmomenttabelle angezogen. Verwenden Sie keinen Hammer, kein Rohr oder Ähnliches, um das Drehmoment zu erhöhen. Eine Erhöhung des Drehmomentes ergibt keine Erhöhung der Spannkraft, sondern beschädigt das Spannfutter. Das Werkzeug muss vertikal in den Halter montiert werden (siehe Abb.).

Kombinieren Sie nicht verschiedene Verlängerungen. Bitte nicht auf der Maschine ein-/oder ausspannen.

Please use wrench provided to clamp the cutting tool into the chuck to the specified clamping torque. Do not use a hammer, pipe, or any other device to exert added torque on the wrench. Excessive torque will damage the clamping chuck. The tool should be mounted in the holder in the vertical position as shown in fig.

Do not combine several extensions.

Do not clamp or unclamp on the machine.

Tightening of tool with torque wrench only as per specified torque.

Das Hi-Power Fräserspannfutter sollte nie ohne Schneidwerkzeug gespannt werden. Die einwirkenden Spannkraften verursachen eine permanente Verformung der Innenbohrung.

The Hi-power milling chuck should never be tightened without a cutting tool inside the bore. High gripping forces will cause permanent ID deformation.

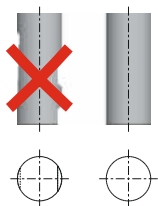
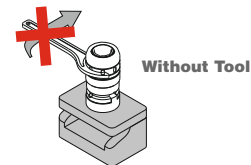

Die beste Leistung des Hi-Power Fräserspannfutters wird erreicht, wenn das Schneidwerkzeug rund ist, ohne Weldon- oder Whistle Notch-Flächen. Schneidwerkzeuge mit Weldon- oder Whistle Notch-Flächen können gespannt werden, haben jedoch einen negativen Einfluss auf Rundlauf und Wuchtgüte.

Best performance from the Hi-power milling chuck is attained when the cutting tool shank is round, without flats and within h6 tolerance. Cutting tools with flat or irregular shapes should not be used as it damages the product.

Maximale Spannkraft im verriegelten Zustand des schlanken HPMC: Die maximale Spannkraft des schlanken HPMC wird bei einem Spaltmaß von 0,3 mm (vgl. Abbildung oben) erreicht. Die Verriegelung wird unter Verwendung eines passenden Hakenschlüssels durch Anzug im Uhrzeigersinn (bei Betrachtung von der erkeugseite) erreicht.

Maximum clamping force of the slim HPMC is achieved with a clearance of 0.3 mm (refer the fig). Locking is achieved using a suitable torque wrench by clockwise tightening.

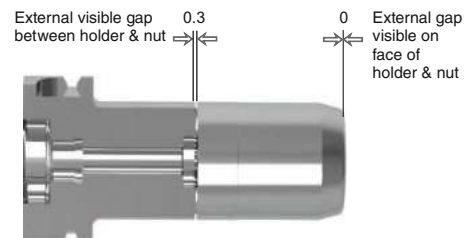

### Wartung / Maintenance

Wenn das Hi-Power Fräserspannfutter über einen längeren Zeitraum nicht benutzt wird, lösen Sie die Mutter, säubern und trocknen Sie diese und verwenden Sie ein Rostschutzmittel; wasserlösliche Kühlmittel, Rost, Ölfilm, Staub usw., die auf dem Spannfutter bleiben, können verkleben und zu Betriebsausfällen führen, daher sollten diese ebenfalls gesäubert, getrocknet und mit einem Rostschutzmittel behandelt werden.

If the Hi-power milling chucks are not used over a prolonged period of time, loosen the nut, wipe clean, dry and apply rust inhibitor. Water-soluble coolant, rust, oil film, dust, etc. remaining on the Hi-power milling chucks may stick and result in operation failure, so please wipe them clean and dry, and apply rust inhibitor.



Super collet Spannzangenfutter - Eigenschaften und Vorteile  
 Super collet chuck - Features & Advantages

**Eigenschaften**  
 Hoch Spannkraft,  
 Hoch Rundlauf,  
 Hoch Steifigkeit und Gleichgewicht  
 Rundlaufgenauigkeit 5µm @ 4D  
 Hohe Rundlaufgenauigkeit durch kompaktes Design

**Features**  
 High Clamping force,  
 High Concentricity,  
 High Rigidity and balance  
 Run-out within 5µm @ 4D  
 Integrated run-out accuracy with compact design

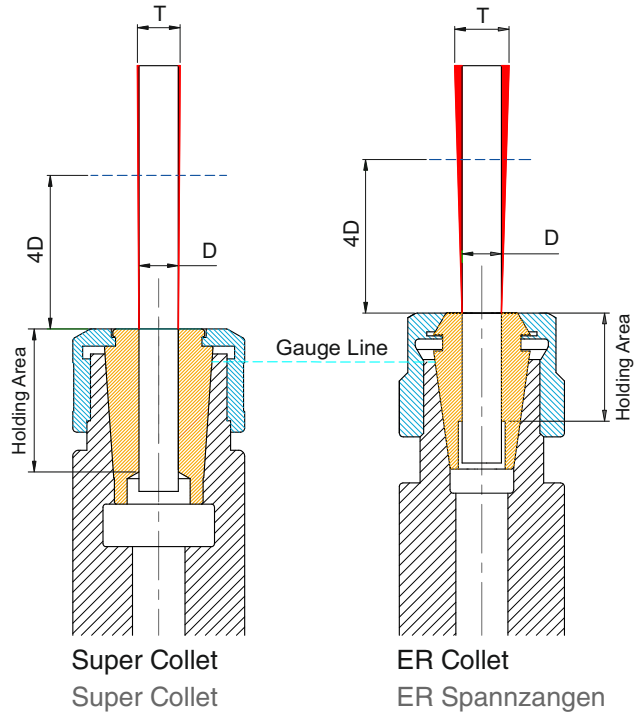

**Vorteile**

**Super Collet**

- Schlankes Design eliminiert Störungen
- Kräfte laufen axial zur Mittellinie des Werkzeughalters um den Halt zu verbessern
- Bessere Genauigkeit durch mehr Umschließung

**Super Collet**

- Slim design allows for better reach
- Force is perpendicular to center line of tool holder for better grip
- More gripping area creates better accuracy

**Advantages**

**ER Spannzangen**

- Größere Spannzangen Ø = Größere Muttern Ø
- Spannkkräfte laufen winklig zur Mittellinie des Werkzeughalters
- Geringere Genauigkeit durch kleinere Umschließung

**ER Collet**

- Wide collets = wide nut design
- Force is angular to center line of tool holder
- Less gripping area results in lesser accuracy

Anzugsmoment Diagramm  
 Tightening Torque Chart

Spannbereich Clamping Range Ø	Auszugsmoment (Nm) Tightening Torque (Nm)
SCF06	20
SCF10	25
SCF13	30
SCF16	40
SCF20	50
SCF25	60

Optionale Spannmutter mit Dichtscheibe verhindert, dass Verschmutzungen und Späne in die Spannzange gelangen  
 Optional internal coolant for coolant through applications. Prevents chips, dirt & swarf from entering the slots of the collets



Super collet Spannzangenfutter - Betriebsanleitung  
Super collet chuck - Operating Instructions

1. Setzen sie die Spannzange wie dargestellt in die Mutter ein  
Assemble the super collet into the nut as shown

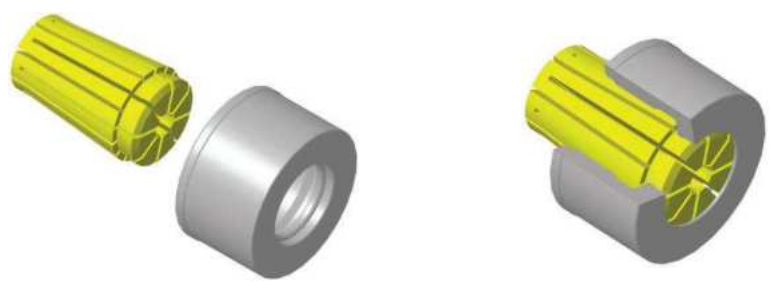

2. Setzen sie nun die in die Mutter montierte Spannzange in das Spannfutter  
Insert the assembled nut & super collet into the chuck



3. Setzen Sie das Werkzeug in die Spannzange ein und ziehen Sie es mit dem Spannschlüssel fest  
Insert the tool into the super collet and lock it with the specified friction wrench

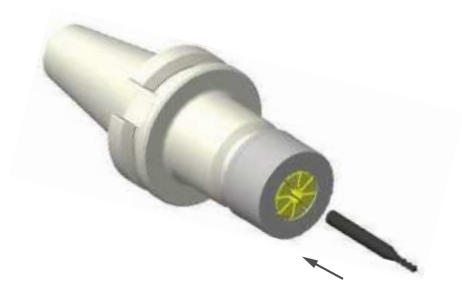

4. Ziehen Sie die Mutter mit dem Spannschlüssel entsprechend dem angegebenen Drehmoment an  
Use the friction wrench to tighten the nut according to the mentioned torque value



5. Verwenden Sie den empfohlenen Drehmomentschlüssel mit Drehmomentschlüsselköpfen, um bessere Ergebnisse zu erzielen  
Use our recommended torque wrench with torque wrench heads for better results



DIN 69871 / ISO7388-1(SK)

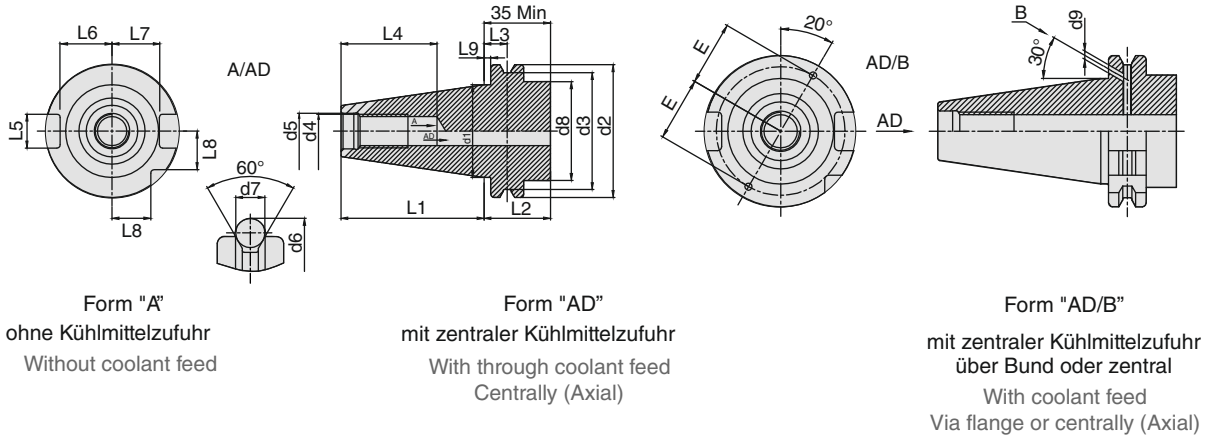

Size	d1	d2	d3	d4	d5	d6	d7	d8	d9	L1	L2	L3	L4	L5	L6	L7	L8	E
30	31,75	50,00	44,30	M12	13	59,30	7	45max	–	47,80	19,1	11,1	30,0min	16,1	19,0	16,4	15,0	-
40	44,45	63,50	56,25	M16	17	72,30	7	50max	4	68,40	19,1	11,1	45,0min	16,1	25,0	22,8	18,5	27
50	69,85	97,50	91,25	M24	25	107,25	7	80max	6	101,75	19,1	11,1	55,0min	25,7	37,1	35,5	30,0	42

JIS B6339 (MAS 403 BT)

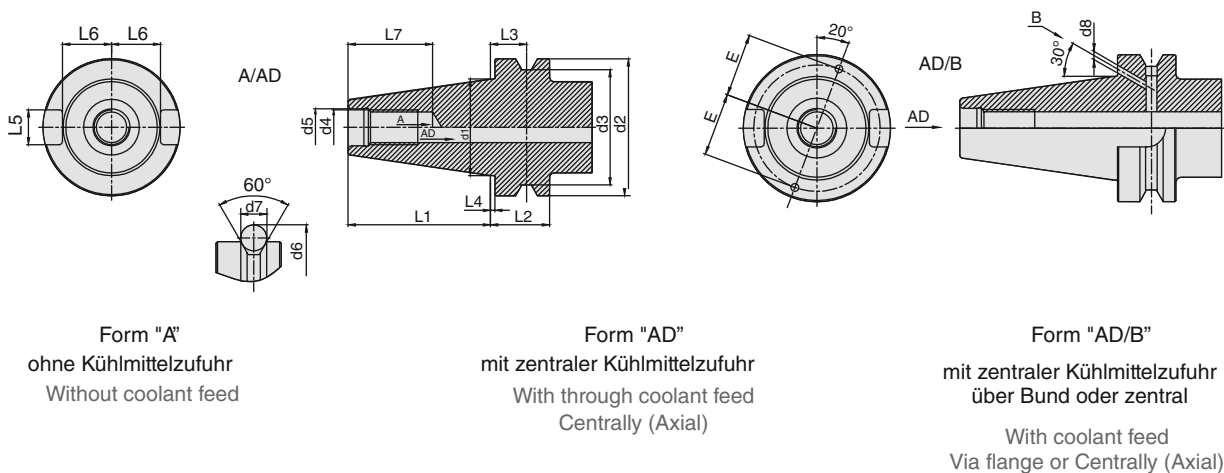

Size	d1	d2	d3	d4	d5	d6	d7	d8	L1	L2	L3	L4	L5	L6	L7	E
30	31,75	46	38	M12	12,5	56,27	8	–	48,40	22,0	13,60	2	16,1	16,3	35min	–
40	44,45	63	53	M16	17,0	75,68	10	4	65,40	27,0	16,60	2	16,1	22,5	42min	27
50	69,85	100	85	M24	25,0	119,00	15	6	101,80	38,0	23,20	3	25,7	35,3	55min	42

Form "AD"  $\rightleftharpoons$  Form "B"

Typ 1 / Type 1

Form "AD" Form "AD/B"

Form "AD"  
(Auslieferungszustand)  
(Delivery Condition)



Bild.1  
Fig.1

Form "B"

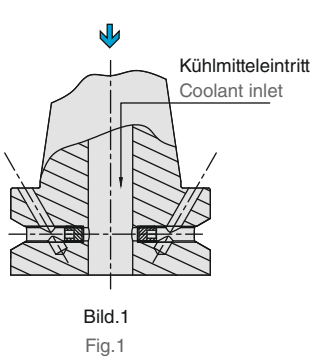

Bild.2  
Fig.2

Im Anlieferzustand sind die Aufnahmen für eine Kühlmittelzuführung nach Form AD (durch die Mitte, siehe Fig.1) ausgelegt. Zum Umstellen auf Form B die M5 Schraubenherausschrauben (siehe Fig.2) und mit Loctite sichern.

As delivered the adaptors are suitable for coolant supply according to form AD (centrally as shown in Fig.1). To switch to form B, unscrew the M5 screws to the top as shown in the Fig.2 and secure with Loctite.

Typ 2 / Type 2

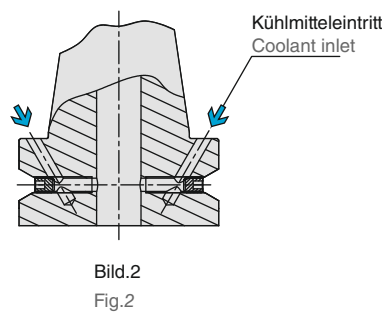
Form "AD"  
(Auslieferungszustand)  
(Delivery Condition)



Bild.1  
Fig.1

Form "B"

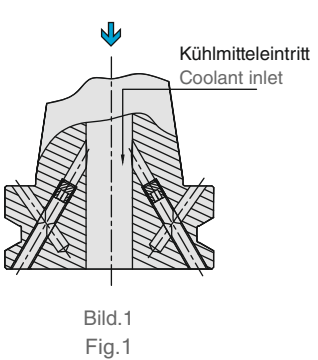

Bild.2  
Fig.2

Im Anlieferzustand sind die Aufnahmen für eine Kühlmittelzuführung nach Form AD (durch die Mitte, siehe Fig.1) ausgelegt. Zum Umstellen auf Form B die M5 Schraubenherausschrauben (siehe Fig.2) und mit Loctite sichern

As delivered, the adaptors are suitable for coolant supply according to form AD (centrally as shown in Fig.1). To switch to form B, unscrew the M5 screws to the top as shown in the Fig.2 and secure with Loctite

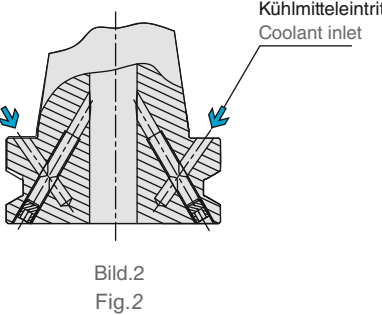
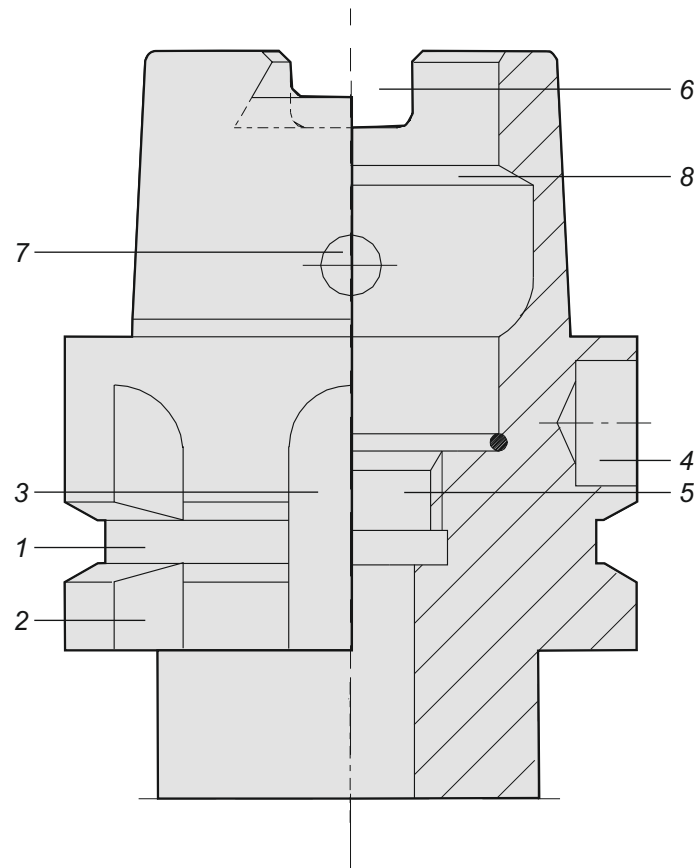

- 1 Greiferrille – umlaufende Nut
- 2 Deutsches Eck – sichelförmige Kerbe quer zur Greiferrille (dient zur Indexierung)
- 3 Mitnehmernut am Bund – zur Indexierung oder zur Aufnahme in einem Werkzeugmagazin oder Greifer. Bei HSK-B/D gleichzeitig zur formschlüssigen Drehmomentübertragung zur Spindel
- 4 Codierbohrung – zur Aufnahme eines Datenträgers (Codierchip) im Bund
- 5 Anschlussgewinde für Kühlmittelübergabeeinheit – zur Aufnahme des Kühlmittelrohrs
- 6 Mitnehmernut am Kegelschaft – formschlüssige Drehmomentübertragung zur Spindel
- 7 Radiale Zugriffsbohrung im Kegelschaft – zur Betätigung Manueller Spannsysteme
- 8 Spannschulter – Ringfläche, an der das Werkzeug eingezogen wird

- 1 Gripper groove – circular groove
- 2 Index notch – sickle-shaped notch across Gripper groove
- 3 Keyway on collar – index notch e.g. for tool magazines. Form closed torque transmission to spindle for HSK-B/D
- 4 Coding/identification – hole in collar for attachment of identification system (code chip)
- 5 Thread for coolant tube – for attachment of coolant tube
- 6 Keyway on taper shank – form closed torque transmission to spindle
- 7 Radial bore in taper shank – necessary for manual clamping systems
- 8 Clamping shoulder – circular chamfer for clamping

Übersicht Werkzeugschäfte HSK DIN 69893  
 Overview tool shanks HSK DIN 69893

Form "A"

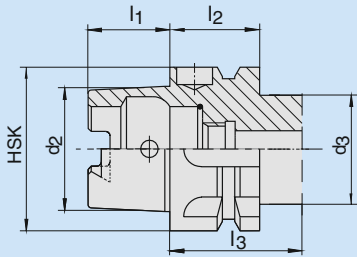

Der Hohlenschaftkegel für automatischen Werkzeugwechsel mit Greif- und Indexiernut. Manuelle Betätigung durch Zugriffsbohrung im Kegel möglich. Das Drehmoment wird kraft- und formschlüssig übertragen

Form "B"

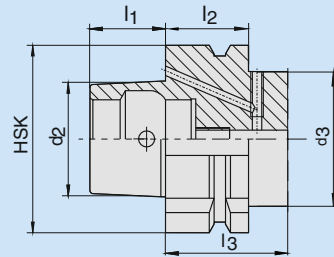

Hollow-shank taper for automatic tool changing with gripping and locating groove. Manual operation is possible through the access hole in the taper. Torque is transmitted both positively and non-positively.

Form "C"

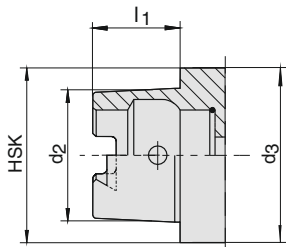

Der Hohlenschaftkegel für manuellen Werkzeugwechsel. Betätigung durch Zugriffsbohrung im Kegel. Das Drehmoment wird kraft- und formschlüssig übertragen.

Form "D"

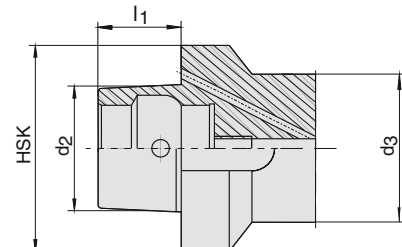

Hollow-shank taper for manual tool changing. Operation is possible through the access hole in the taper. Torque is transmitted both positively and non-positively.

Form "E"

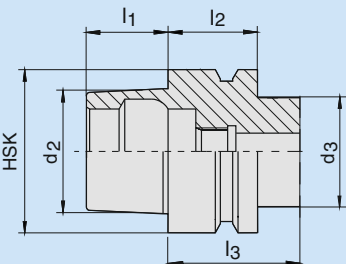

Der Hohlenschaftkegel für automatischen Werkzeugwechsel (manuelle Betätigung durch Zugriffsbohrung im Kegel nicht möglich). Das Drehmoment wird kraftschlüssig übertragen.

Form "F"

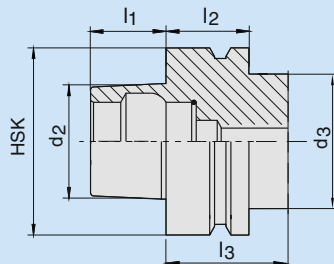

Hollow-shank taper for automatic tool changing (manual operation through access hole in taper not possible). Torque is transmitted non-positively.

HSK-A+C	d2	d3	l1	l2	l3	HSK-B+D	d2	d3	l1	l2	l3
32	24	26	16	20	35	40	24	34	16	20	35
40	30	34	20	20	35	50	30	42	20	26	42
50	38	42	25	26	42	63	38	53	25	26	42
63	48	53	32	26	42	80	48	67	32	26	42
80	60	67	40	26	42	100	60	85	40	29	45
100	75	85	50	29	45						

HSK-E	d2	d3	l1	l2	l3	HSK-F	d2	d3	l1	l2	l3
25	19	20	13	10	20	50	30	42	20	26	42
32	24	26	16	20	35	63	38	53	25	26	42
40	30	34	20	20	35	80	48	67	32	26	42
50	38	42	25	26	42						
63	48	53	32	26	42						

Permissible Residual Unbalance,  $e_{per}$  in g-mm/kg of rotor weight

Maximum permissible residual unbalance,  $e_{per}$  (from ISO 1940/1)

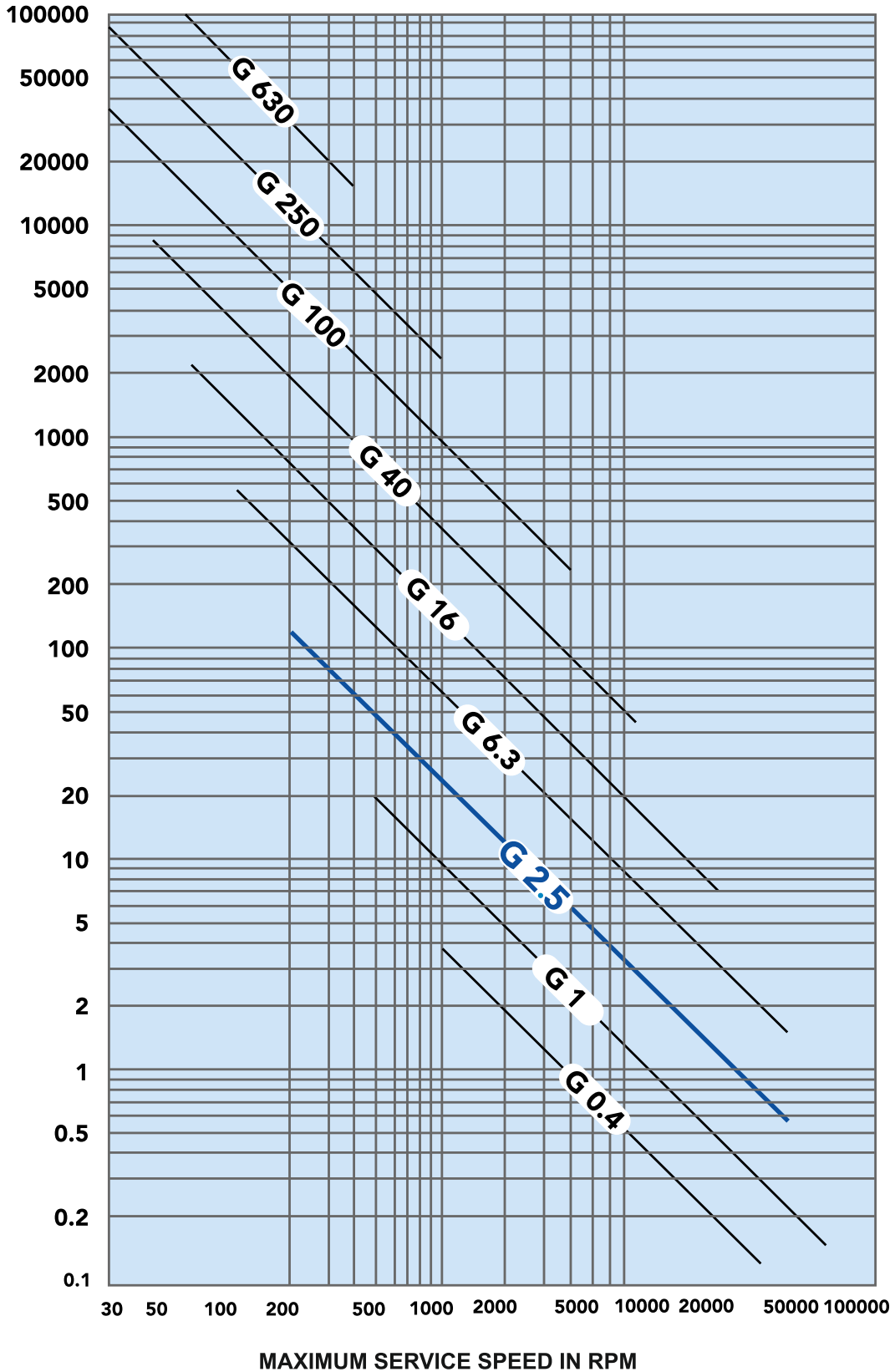

### Programmaktualität

Im Rahmen der kontinuierlichen Aktualisierung unseres Produktprogrammes nehmen wir nicht nur neue und damit technisch bessere Produkte im Programm auf, sondern führen auch eine intensive Programmbereinigung durch. Es kann also im Einzelfall passieren, dass wir einen von Ihnen bestellten Artikel nicht mehr lagermäßig führen. Sie erhalten dann von uns in der Regel ein technologisch besseres Produkt, mindestens aber eine gleichwertige Alternative. In Zweifelsfällen wird sich unser Verkaufsteam mit Ihnen in Verbindung setzen, um eine für Sie optimale Ausführung zu bestimmen. Durch diese Vorgehensweise ist sichergestellt, dass Sie stets mit Produkten beliefert werden, die technisch auf dem neuesten Stand sind.

Eine Verpflichtung zur Lieferung von noch im Katalog oder in der Preisliste abgebildeten Produkten, die intern aber bereits programmbereinigt wurden, übernehmen wir deshalb nicht.

### Preise

Dieser Katalog enthält keine Preise. Diese entnehmen Sie bitte der jeweils gültigen Preisliste.

### Sonderformen

Sollten Sie eines Ihrer Bearbeitungsprobleme nicht mit einem unserer lagergängigen Produkte lösen können, bieten wir Ihnen Sonderformen oder zeichnungsgebundene Werkzeuge auf Anfrage an.

Unsere Anwendungstechniker beraten Sie gern.

### Eingeschränkte Garantie

Für einen Zeitraum von einem (1) Jahr ab Rechnungsdatum gewähren wir Ihnen eine Garantie gegen Herstellungsfehler. Unsere Garantie deckt keine Schäden ab, die durch Unfälle oder unbefugte Änderungen verursacht wurden. Wir bitten unsere Kunden und Partner die gekauften Teile nach Erhalt zu überprüfen.

Nachdruck, auch auszugsweise, ist nur mit unserer Zustimmung gestattet. Alle Rechte vorbehalten. Irrtümer, Satz- oder Druckfehler berechtigen nicht zu irgendwelchen Ansprüchen. Abbildungen, Ausführungen und Maße entsprechen dem neuesten Stand bei Herausgabe dieser Druckschrift. Technische Änderungen müssen vorbehalten sein. Die bildliche Darstellung der Produkte muss nicht in jedem Falle und in allen Einzelheiten dem tatsächlichen Aussehen entsprechen.

This publication may not be reprinted in whole or part without our permission. All rights reserved. No rights may be derived from any errors in content or from typographical or typesetting errors. Diagrams, features, and dimensions represent the current status of the date of issue on this catalog. We reserve the right to make technical changes. The visual appearance of the products may not necessarily correspond to the actual appearance in all cases or in every detail.

### Updating of our product range

In the course of updating our product range, we are not only constantly adding new and technically improved products to our program, but at the same time we are also continually reassessing the product range. In exceptional cases, it is possible that we no longer have the product you order on stock. You will then receive a technically improved product or an equivalent alternative. In any case of doubt, our sales team will contact you in order to determine the optimal version for you. We ensure that you will always get the most updated products.

We therefore do not assume any obligation to supply products appearing in the catalogue and/or in the price list which have already been adjusted out of the system internally.

Bilz and its partners shall have no liability for indirect, incidental or consequential errors in this catalog.

### Prices

For prices, please refer to the current price list.

### Special designs

If you find that your specific machining problems cannot be resolved with any of our permanently stocked products, then we can supply special designs or tools made according to drawings.

Our application technicians will be glad to help you.

### Limited Warranty

For a period of one (1) year from the invoice date (of end user) against manufacturing defects. Our warranty doesn't cover damage caused by accidents or unauthorized modifications. We request our Customers/Partners to ensure parts on receipt.



# Weitere Bilz Produktkataloge Further Bilz product catalogues

Fordern Sie heute noch kostenlos per E-Mail  
Order our catalogues free of charge by email

Unser **ThermoGrip** Schrumpfgerätekatalog  
Our **ThermoGrip** Shrink Machine Catalogue



Unser **ThermoGrip** Schrumpffutterkatalog  
Our **ThermoGrip** Shrink Chucks Catalogue



Unser **TapGrip** Spannsystemekatalog  
Our **TapGrip** Clamping Systems Catalogue



Unser **BTC** Gerätekatalog  
Our **BTC** Machine Catalogue





**BILZ WERKZEUGFABRIK  
GmbH & Co. KG**  
Vogelsangstr. 8  
73760 Ostfildern  
Deutschland / Germany  
Telefon +49 711 348 01 - 0  
Telefax +49 711 348 12 56  
info@bilz.de  
www.bilz.com

**OTTO BILZ (INDIA) PVT. LTD.**  
5A-5B/6A, KIADB Industrial Area,  
Doddaballapur - 561203  
Bengaluru District  
India  
Tel +91 080 22638700  
Fax +91 080 22638702  
sales@bilzindia.com  
www.bilz.in



*Produktions- und Vertriebsstandorte der LEITZ-Group  
Production and sales locations of the LEITZ Group*

- **Bilz**
- **Boehlerit**
- **Leitz**



**BILZ WERKZEUGFABRIK  
GmbH & Co. KG**  
Vogelsangstr. 8  
73760 Ostfildern  
Deutschland / Germany  
Telefon +49 711 348 01 - 0  
Telefax +49 711 348 12 56  
info@bilz.de  
www.bilz.com

**BILZ TOOL PVT. LTD.**  
13-B, KIADB Industrial Area,  
Doddaballapur - 561203  
Bengaluru District  
India  
Tel +91 7022970327  
Fax +91 080 22638702  
sales@bilztool.com  
www.bilz.in



*Produktions- und Vertriebsstandorte der LEITZ-Group  
Production and sales locations of the LEITZ Group*

- **Bilz**
- **Boehlerit**
- **Leitz**